

OPERATOR'S MANUAL

KUBOTA EXCAVATOR

MODELS **KX** 016-4
018-4

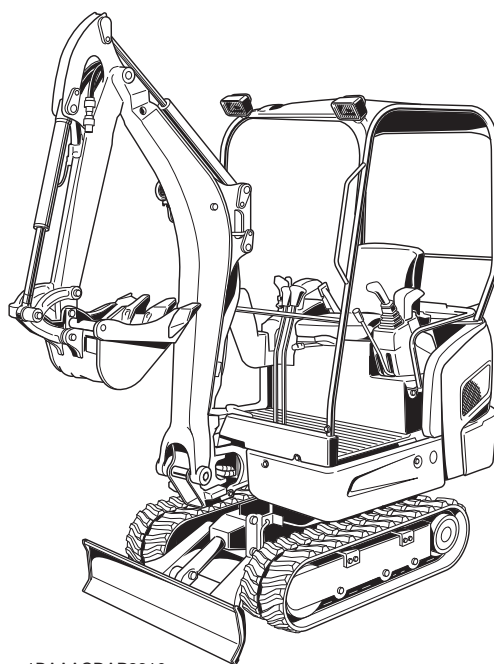

1BAAACDAP2310

READ AND SAVE THIS MANUAL













































Kubota

ABBREVIATION LIST

Abbreviations	Definitions
API	American Petroleum Institute
ASTM	American Society for Testing and Materials, USA
CECE	Committee for European Construction Equipment
DIN	German Institute for Standards, Federal Republic of Germany
EN	European Standard
OPG	Operator Protective Guards
FRONT	"Front" means the front view towards the boom and dozer
Hi	High speed
ISO	International Standardization Organization
JIS	Japanese Industrial Standard
L	Volume (Liter)
L/min	Liter per minute
Lo	Low speed
MIL	Military Standards
rpm	Revolutions per minute
ROPS	Roll-Over Protective Structures
SAE	Society of Automotive Engineers, USA
TPSS	Two Pattern Selection System
AI	Auto Idle

GENERAL SYMBOLS

The instruments and operation elements have been marked with a series of symbols in order to simplify the operation of your excavator. These symbols are listed below with the respective descriptions.

	Safety alert Symbol		Boom swing (Left)
	Warning lamp "Fuel level too low"		Boom swing (Right)
	System lamp		Dozer raise
	Warning lamp "Engine Oil pressure "		Dozer lower
	Warning lamp "Battery charge"		Operation direction of control lever
	Warning lamp "Auto Idle (AI) Lamp"		Operation direction of control lever
	Indicator lamp "Glow"		Read operator's manual
	Working light switch		Lock
	Horn		Unlock
	Wiper/Washer switch		Engine stop control lamp
	Diesel		Reducing / Increasing track width
	Hydraulic fluid		Rotary beacon indicator on/off
	Gear oil		Display selector switch
	Grease		User setting switch
	Fast		AUX proportional switch
	Slow		Working light switch
	Excavator - Overhead movement toward the front		Key in
	Excavator - Overhead movement toward the rear		Key out
	Boom raise		AUX
	Boom lower		Maintenance
	Arm out		Clock warning
	Arm in		
	Bucket crowd		
	Bucket dump		

FOREWORD

You are now the proud owner of a KUBOTA excavator. This excavator is a product of KUBOTA quality engineering and manufacturing. It is made of the fine materials and under rigid quality control systems. It will give you long, satisfactory service. To obtain the best use of your excavator, please read this manual carefully. It will help you become familiar with the operation of the excavator and contains many helpful hints about excavator maintenance. It is KUBOTA's policy to utilize as quick as possible every advance in our research. The immediate use of new techniques in the manufacture of products may cause some small parts of this manual to be outdated. KUBOTA distributors and dealers will have the most up-to-date information. Please do not hesitate to consult with them.

Please note that there may be some differences between your actual machine and the illustrations in the instructions.



SAFETY FIRST

This symbol, the industry's "Safety Alert Symbol", is used throughout this manual and on labels on the machine itself to warn of the possibility of personal injury. Read these instructions carefully. It is essential that you read the instructions and safety regulations before you attempt to assemble or use this unit.



DANGER : Indicates an imminently hazardous situation which, if not avoided, will result in death or serious injury.



WARNING : Indicates a potentially hazardous situation which, if not avoided, could result in death or serious injury.



CAUTION : Indicates a potentially hazardous situation which, if not avoided, may result in minor or moderate injury.

IMPORTANT : Indicates that equipment or property damage could result if instructions are not followed.

NOTE : Gives helpful information.

CONTENTS

▲SAFE OPERATION	1
DANGER, WARNING AND CAUTION LABELS	8
CARE OF DANGER, WARNING AND CAUTION LABELS	13
DEALER SERVICE.....	1
TECHNICAL DATA.....	2
DESCRIPTION OF MACHINE PARTS.....	3
INSTRUMENT PANEL AND CONTROL ELEMENTS.....	4
CHECKS BEFORE START	7
DAILY CHECKS.....	7
Working Light Switch	7
OPERATION OF THE ENGINE.....	8
STARTING THE ENGINE	8
Display Selector Switch	9
Battery Charge Lamp.....	11
Engine Oil Pressure Warning Lamp	11
Glow Lamp.....	11
LCD Display for Normal Operation	12
LCD Display for Warning	13
Warning Lamp	13
Checkpoints after Starting the Engine	14
STARTING THE ENGINE UNDER COLD CONDITIONS.....	14
Precautions in case of Overheat.....	14
STOPPING THE ENGINE.....	14
Engine Stop Knob.....	15
STARTING WITH AN AUXILIARY BATTERY	15
Observe Following Guidelines when Starting with an Auxiliary Battery.....	15
EXCAVATOR OPERATION	16
RUNNING-IN OF THE NEW EXCAVATOR.....	16
Do not Work with Full Engine Rpm's or Full Loads during the First 50 Working Hours..	16
Oil Change in the Run-in Stage	16
STARTING	16
Seat Belt	16
Operator's Seat.....	16
Lock Lever (Unload Lever)	18
Working Light Switch	18
Beacon Light Switch	18
OPERATION OF TRACK WIDTH CHANGE.....	19
OPERATION OF THE DOZER	19
Adjustment of the Dozer Width.....	20
DRIVING	20
Drive Levers(Right,Left).....	22
Travel Speed Switch.....	22
TURNS.....	23

Pivot Turn	23
Spin Turn	24
UP AND DOWNHILL DRIVING.....	25
TWO PATTERN SELECTION SYSTEM(TPSS)	26
Pattern Change.....	26
OPERATION OF THE BOOM.....	27
OPERATION OF THE ARM.....	27
OPERATION OF THE BUCKET	28
SWIVEL(UNIT SWING)OPERATION	28
BOOM SWING OPERATION.....	29
AUXILIARY PORT OPERATION	29
PARKING ON A SLOPE	30
IMPORTANT INFORMATION ON EXCAVATOR OPERATION	30
TRANSPORTING THE EXCAVATOR ON A VEHICLE.....	31
LIFTING OF THE EXCAVATOR.....	33
MAINTENANCE.....	35
MAINTENANCE INTERVALS	36
OPENING AND CLOSING OF PARTS.....	38
Opening and Closing of the Fuel Tank Cap.....	38
Opening/Closing of the Engine Hood	39
Where to store the Grease Gun.....	39
Where to keep Operator's Manual.....	39
Cup Holder.....	39
DAILY CHECKS.....	40
Checking Coolant Level.....	40
Checking Fuel Level	40
Checking Engine Oil Level.....	41
Checking Hydraulic Oil Level.....	42
Lubrication Points	43
Check Fan Belt	44
Checking Radiator and Oil Cooler	44
Checking and Cleaning Engine and Electrical Wiring.....	44
Washing Whole Machine	44
REGULAR CHECKS AND MAINTENANCE WORK	45
EVERY 50 SERVICE HOURS	45
Draining Fuel Tank	45
Checking Water Separator	45
Battery	46
Battery Charging.....	46
Greasing Swing Bearing Teeth.....	47
EVERY 200 SERVICE HOURS	47
Checking Radiator Hoses and Clamps.....	47
Inspection and Cleaning Air Filter Element.....	47
Air Filter Maintenance.....	47
Greasing Swing Ball Bearing.....	48
Checking Fuel Line and Intake Air Line.....	48
EVERY 250 SERVICE HOURS	48
Changing Engine Oil(First Engine Oil Change after 50 Service Hours)	48
Replacing Engine Oil Filter(First Engine Oil Filter Change after 50 Service Hours).....	49

Checking the Fan Belt Tension.....	49
EVERY 500 SERVICE HOURS	50
Drive unit Oil Change(First Oil Change of the 50 hours)	50
Replacing Fuel Filter Element.....	50
Replacing Hydraulic Return Filter Element(first replacement after 250 service hours) ..	51
EVERY 1000 SERVICE HOURS	51
Hydraulic Oil Check for Machines with Hydraulic Breakers.....	51
Hydraulic Oil Change(Including Replacing Suction Filter in Hydraulic Tank)	52
EVERY 1000 SERVICE HOURS OR ONCE A YEAR	53
Replacing Air Filter Element	53
EVERY 1500 SERVICE HOURS	53
Checking Fuel Injection Nozzle(Injection Pressure)	53
EVERY 2000 SERVICE HOURS	53
Changing Front Idler and Track Roller Oil	53
Checking Alternator and Starter Motor	53
EVERY 3000 SERVICE HOURS	53
Checking Injection Pump	53
ANNUAL SERVICE	53
Electrical Wiring and Fuses	53
BIENNIAL SERVICING	54
Replacing of Radiator Hoses	54
Changing Radiator Coolant	54
Replacing Fuel Hose	55
Replacing Intake Air line	55
OTHER ADJUSTMENTS AND REPLACEMENTS.....	56
PURGING FUEL SYSTEM	56
ADJUSTMENT OF TRACKS	56
Rubber Tracks	56
Special Information when Using Rubber Tracks.....	57
CHANGING THE BUCKET	58
FUSES	58
Replacing Fuses	58
Fuse Capacities and Circuits	58
Auxiliary Electric	59
Slow Blow Fuse	59
TROUBLESHOOTING.....	60
KUBOTA I.C.S. NAVIGATION LIST OF MESSAGES	62
OPERATION UNDER COLD WEATHER CONDITIONS	67
PREPARATION FOR OPERATION IN COLD WEATHER	67
PROCEDURE AFTER DONE WORK.....	67
LONG STORAGE	68
RECOMMENDED OILS.....	70
APPENDICES.....	71
MAIN DIMENSIONS	71
LIFTING CAPACITY	72



SAFE OPERATION

Careful operation is your best insurance against an accident.

Read and understand this manual carefully, before operating the excavator.

Every user, however experienced, should carefully read and understand this manual and those of the attachments and accessories before operating the excavator. The owner is obliged to inform all operators of these instructions in detail.

Keep this manual in the storage location. (See "Where to keep Operator's Manual" in "MAINTENANCE" section.)

1. BEFORE OPERATION

1. Know your equipment and its limitations. Read and understand this entire manual before attempting to start and operate the excavator.
2. Obey the danger, warning and caution labels on the machine.
3. Track can be set at the narrow width (990 mm) or the standard width (KX016-4 : 1240 mm, KX018-4 : 1300 mm).
(for details see "OPERATION OF TRACK WIDTH CHANGES")
To change the track width, set the track width fully, standard or narrow width.
If not, the excavator may unintentionally move.

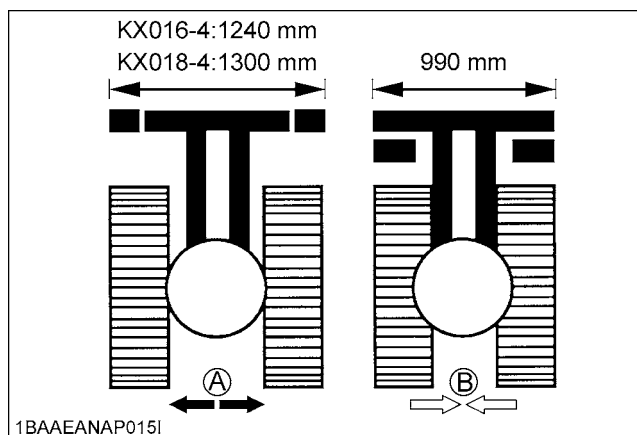

4. For your safety, a ROPS/OPG (Roll-Over Protective Structure, Operator Protective Guards(top guard).) with a seat belt is installed by KUBOTA. Always use the seat belt when the machine is equipped with a ROPS/OPG as this combination will reduce the risk of serious injury or death, should the excavator be upset or falling objects occur.

Do not modify any structural members of the ROPS/OPG by welding, drilling, bending, grinding or cutting, as this may weaken the structure. If any component is damaged, replace it. Do not attempt repairs. If the ROPS/OPG is loosened or removed for any reason, make sure all parts are reinstalled correctly. Tighten mounting bolts to proper torque.

5. ROPS/OPG structure complies with ISO 3471, ISO 3449 and OSHA regulations.
6. The seat belt must be inspected regularly and replaced if frayed or damaged.

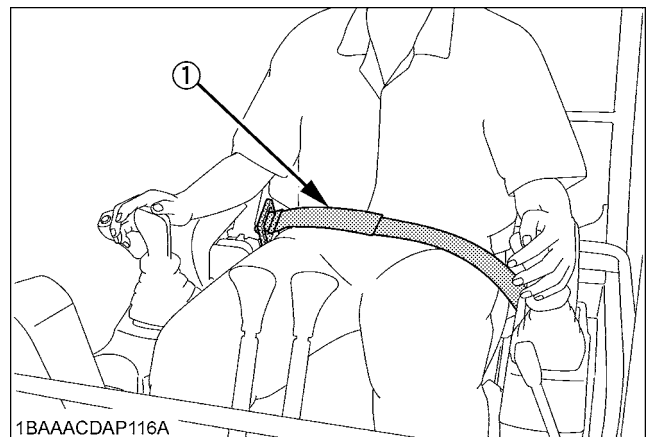

(1) Seat belt

7. Always sit in the operator's seat when starting engine or operating levers or controls.

8. Study control lever pattern A and pattern B. Then choose the one which is most familiar.

Familiarize yourself with the pattern selected by operating the unit slowly and at low engine speed.

- Before changing the pattern, be sure to stop the engine.
- Engage the lock to prevent accidental pattern change.

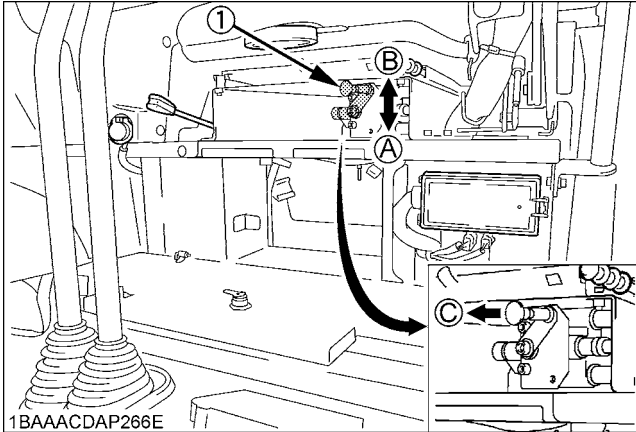

(1) Pattern selector lever (Two Pattern Selection System:TPSS)
 (A) "Pattern A"
 (B) "Pattern B"
 (C) Pull to unlock

9. Do not operate the excavator while under the influence of alcohol, medication, controlled substances or while fatigued.

10. Check the surroundings carefully before using the excavator or when attachments are being attached.

- Pay attention to the overhead clearance with electric wires.

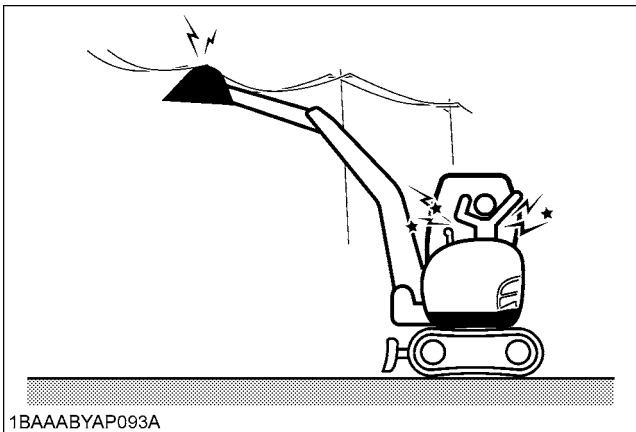

1BAAABYAP093A

- Check for pipes and buried cables before digging.
- Check for hidden holes, obstacles, soft underground, and overhangs.

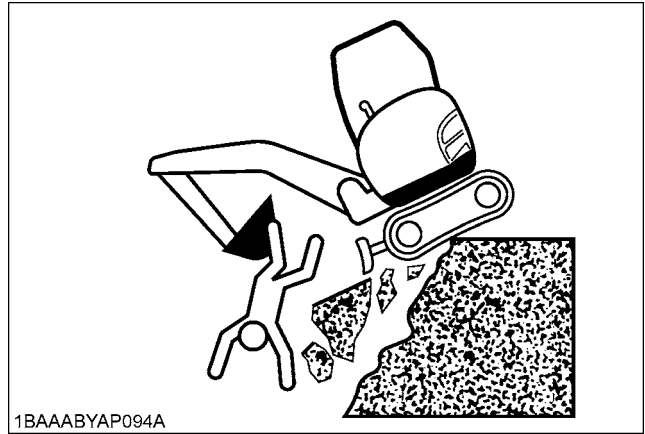

1BAAABYAP094A

- Do not allow any persons within the working range of the excavator during operation.
- Check local regulations before digging and call diggers hotline before working, www.diggershotline.com or 811 (WI) and www.nediggers.com or 1-800-331-5666 (NE).

11. Do not allow anyone to use the excavator until they have been advised of the work to be performed and they have indicated that they have read and understood the operator's manual.

12. Do not wear baggy, torn or oversized clothing when working with the excavator as such clothing can get caught in rotating parts or control elements which can cause accidents or injuries. Wear adequate safety clothing, e.g. safety helmet, safety shoes, eye protection, ear protection, working gloves, etc., as necessary and as prescribed by law or statutes.

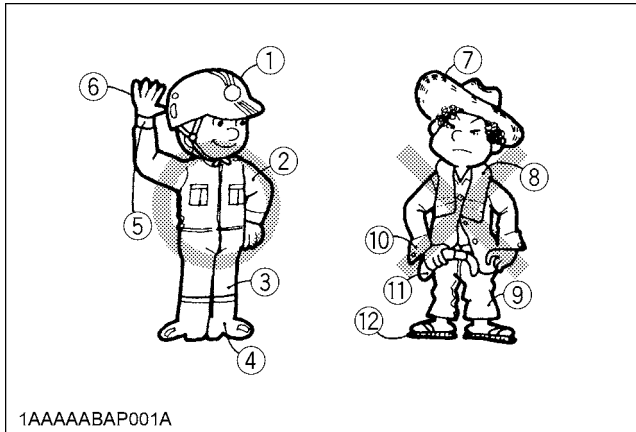

1AAAAABAP001A

- | | |
|---------------------------|-------------------------------|
| (1) Helmet | (7) Straw hat |
| (2) Clothing fit for work | (8) Towel |
| (3) Tight seams | (9) Baggy trousers |
| (4) Good grip footwear | (10) Loose cuffs of the shirt |
| (5) Well fitting cuffs | (11) Baggy shirt |
| (6) Working gloves | (12) Rubber sandals |

13. Do not allow passengers to ride on any part of the excavator at anytime. The operator must remain in the excavator seat during operation.
14. Check levers, pedals and all mechanical parts for correct adjustment and wear. Replace worn or damaged parts immediately. Check nuts and bolts regularly for correct torque.
15. Keep your excavator clean. Heavy soiling, grease, dust and grass can cause fires, accidents or injuries.
16. Use only KUBOTA authorized attachments.
17. Before starting the excavator, be confirm that the excavator has been filled with fuel, lubricated, greased and undergone any required maintenance work.
18. Do not modify the excavator; modifications could lead to unforeseen safety problems.
19. Make sure attachments, particularly those utilizing quick attach systems, are securely mounted.
20. Install protective guards on the excavator when working in areas where objects may fall or be thrown.

2. OPERATING THE EXCAVATOR

1. Mount and dismount of the machine safely. Always face the machine. Always use handrails and available steps and keep yourself well balanced. Do not grab or hold any of the control levers and switches. Do not jump on or off the machine, whether stationary or in motion.
2. Start and control the excavator only from the operator's seat. The driver should not lean out of his seat when the engine is running.
3. Before starting the engine, make sure that the lock levers are in the "Lock" position and all control levers and pedals are in their neutral positions and the seat belt is fastened correctly.
4. Before operating the excavator, make sure that the dozer blade is in front of you. If the levers are activated with the dozer blade at the rear, the tracks will move in the opposite direction of the drive levers.

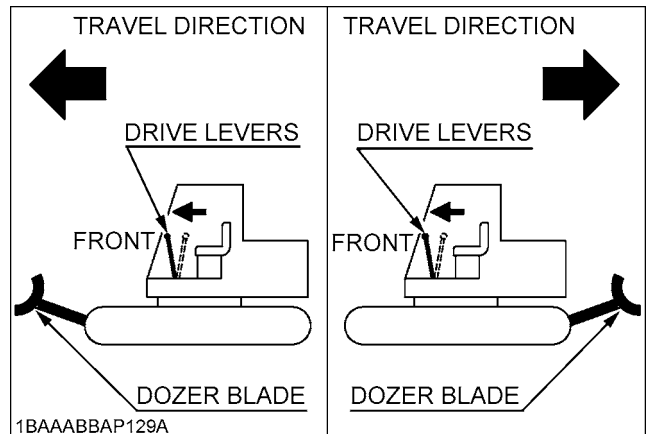

1BAAABBAP129A

5. Do not operate or idle engine in a non-ventilated area. Carbon monoxide gas is colorless, odorless, and deadly.

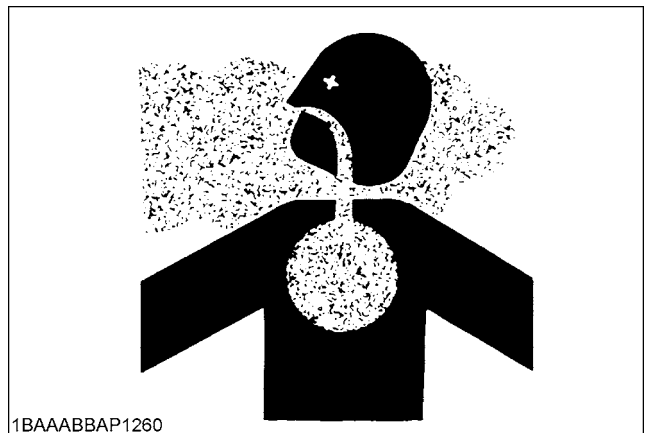

1BAAABBAP1260

6. Keep all safety equipment and covers in place. Replace damaged or missing safety devices.

7. When operating, keep hands and body inside of the ROPS / OPG protective envelope.

Do not touch or depress the control levers or the pedals from outside the cab while the engine is running.

8. Take precautions against tipping over. Stay away from steep slopes and embankments. Do not swing the bucket downhill. Lower the dozer blade when digging. Keep the bucket as low as possible while driving uphill. Turn slowly on slopes (at reduced speed). Do not place the excavator near the edges of trenches and banks, as the earth can give away due to the weight of the excavator.

ALLOWABLE CLIMBING ANGLE : 36 % (20 deg.)

ALLOWABLE ANGLE CROSS : 27 % (15 deg.)

9. Watch where you are going at all times.

Watch for and avoid obstacles. Remain alert for trees, wires and other obstructions.

◆ **Safety for children**

Tragedy can occur if the operator is not alert to the presence of children. Children generally are attracted to machines and the work they do.

1. Never assume that children will remain where you last saw them.
2. Keep children out of the work area and under the watchful eye of another responsible adult.
3. Be alert and shut your machine down if children enter the work area.
4. Never carry children on your machine. There is not a safe place for them to ride. They may fall off and be run over or interfere with your control of the machine.
5. Never allow children to operate the machine even under adult supervision.
6. Never allow children to play on the machine or on the attachments.
7. Use extra caution when backing up. Look behind and down to make sure the area clear before moving.
8. When parking your machine, if at all possible, park on a firm, flat and level surface; if not, park across a slope. Lower the bucket and dozer to the ground, stop the engine, release pressure in the hydraulic system, place the pilot control lock lever in the locked position, remove the key and lock the cab door (if equipped), before you leave.

3. AFTER OPERATION

Before leaving the machine,

- Park the excavator on a firm, flat and level surface. If this is not possible, park across the slope.
- Lower the attachments and the dozer blade to the ground.
- Stop the engine.
- Release pressure in the hydraulic system.
- Lock all control levers.
- Remove the key.
- Lock the cab door (if equipped)

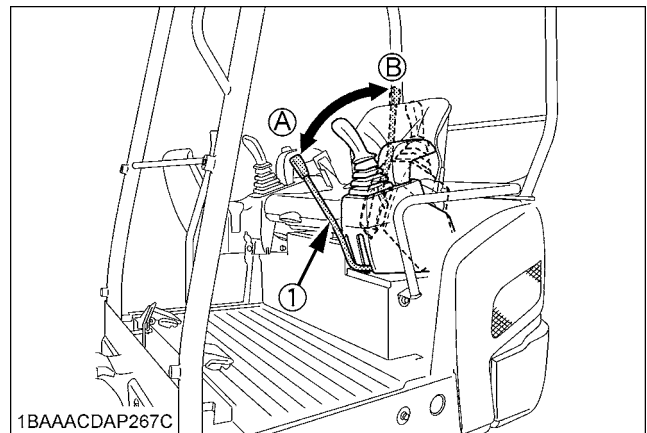
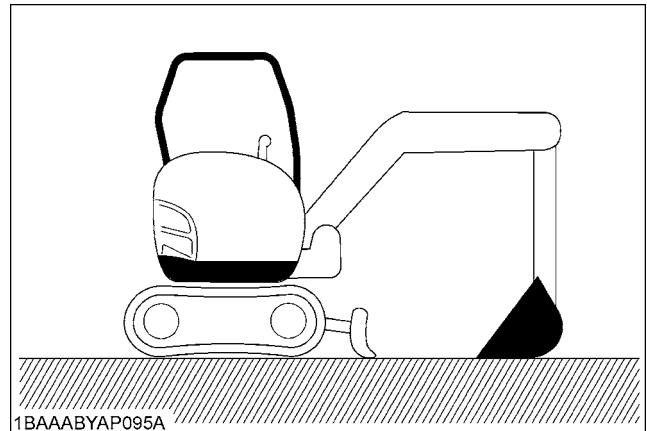

(1) Pilot control lock lever (A) "Unlock"
 (B) "Locked"

4. SAFE LOADING AND TRANSPORT OF THE EXCAVATOR

1. Observe all regulations concerning the transport of excavators on public roads.
2. Use adequately long and robust ramps when loading on the machine. (for details see "TRANSPORTING THE EXCAVATOR ON A VEHICLE")
3. Do not change the running direction and to avoid tipping over, do not try to swing the attachment crosswise to the loading ramps.
4. Lower the attachment onto the transport surface and release the pressure from the hydraulic system. Stop the engine then remove the key. After loading the excavator on a truck, block the tracks with blocks and tie down the excavator with the chain. After loading of the excavator on a truck, engage the swing lock pin.

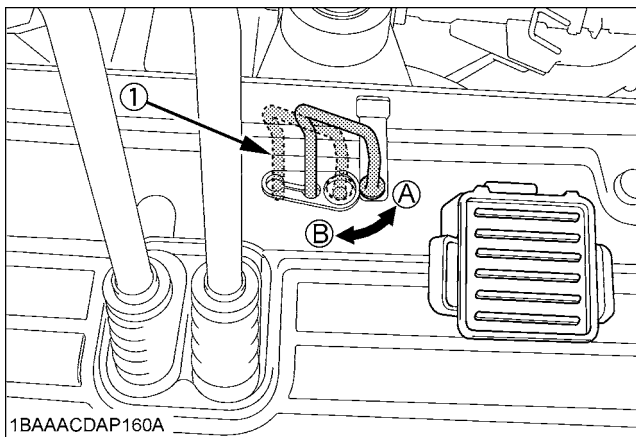

(1) Swing lock pin
(A) "Unlock"
(B) "Lock"

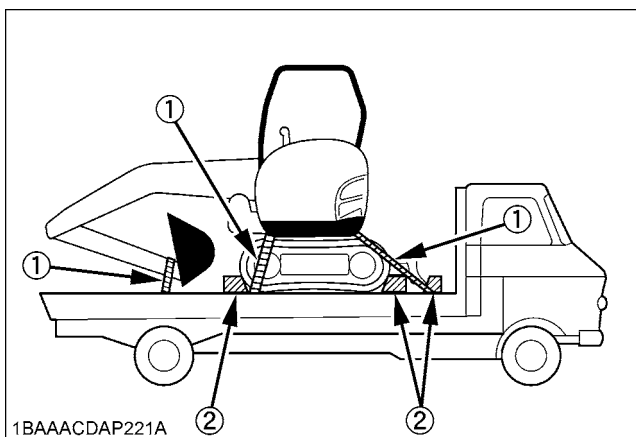

(1) Chain
(2) Block

5. Avoid abrupt braking of the vehicle with the excavator loaded. Sudden braking cause the excavator to move and may cause a serious accident.

6. When towing the excavator or pulling a load, the load must be less than the strength of the towing line attached to excavator. The towing eye should not be used for tie down or lifting of the machine.

Max. drawbar pull at coupling hook	32.3 kN (7261 lbf, 3294 kgf)
Max. vertical load at coupling hook	2.7 kN (607 lbf, 275 kgf)

5. MAINTENANCE

Before doing maintenance work on the excavator, place the machine on a firm, flat and level surface, lower the attachments to the ground, stop the engine, release pressure trapped in the hydraulic system, lock all control levers and remove the key. When dismantling hydraulic parts, make sure that the hydraulic oil has cooled down sufficiently to avoid burns.

Start maintenance work carefully, e.g. loosen plug slowly so that oil will not squirt out.

1. Before doing work on the engine, the exhaust system, the radiator and the hydraulics, let the excavator cool down sufficiently.
2. Always turn off the engine when filling the fuel tank. Avoid spilling and over-filling of fuel.
3. Smoking is prohibited while refueling or handling the battery. Keep sparks and fire away from the fuel tank and battery. Flammable gases escape from the battery, especially during charging.
4. Do not use or charge a refillable type battery if the fluid level is below the LOWER (lower limit level) mark. Otherwise, the battery component parts may prematurely deteriorate, which may shorten the battery's service life or cause an explosion. Check the fluid level regularly and add distilled water as required so that the fluid level is between the UPPER and LOWER levels.
5. Read and follow the directions "STARTING WITH AN AUXILIARY BATTERY" in "OPERATION OF THE ENGINE", when starting with an auxiliary battery.
6. Keep a first-aid box and a fire extinguisher at hand at all times.

7. Do not open the radiator cap before the radiator has cooled down sufficiently
 First loosen the cap to the first stop and allow the system enough time to release the remaining pressure. Then loosen the cap completely.

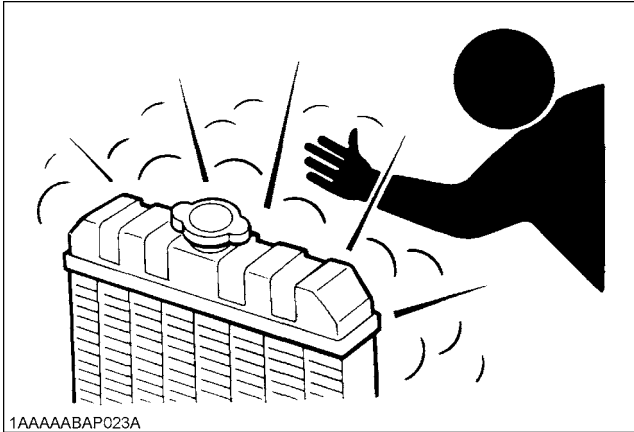

8. To avoid short-circuiting the battery, always remove the ground cable first and attach the positive cable first.
9. Oil under high pressure can penetrate the skin and may be harmful to your health if not treated immediately.
10. Leaking hydraulic fluid has enough pressure to penetrate the skin and cause serious injuries. Leakages from pin holes can be totally invisible. Do not use hands for checking for leaks. Always use a piece of wood or cardboard. It is strongly recommended that you use a face mask or eye protection.
 Should injuries occur with leaking hydraulic fluid, contact a doctor immediately. This fluid can cause gangrene or serious allergic reactions.

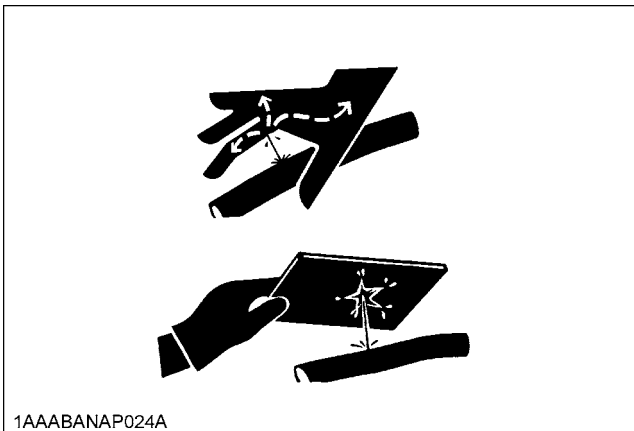

11. To avoid environmental damage from acid and heavy metals, dispose of the battery appropriately.
12. Observe all laws and regulations concerning the disposal of used oil, coolants, solvents, hydraulic fluids, battery acids and batteries.

13. To avoid fire, do not heat the hydraulic components (tanks, pipes, hoses, cylinders) before they have been drained and washed.
14. Use eye protection or a face mask to protect the eyes and respiratory system against dust and other foreign particles.

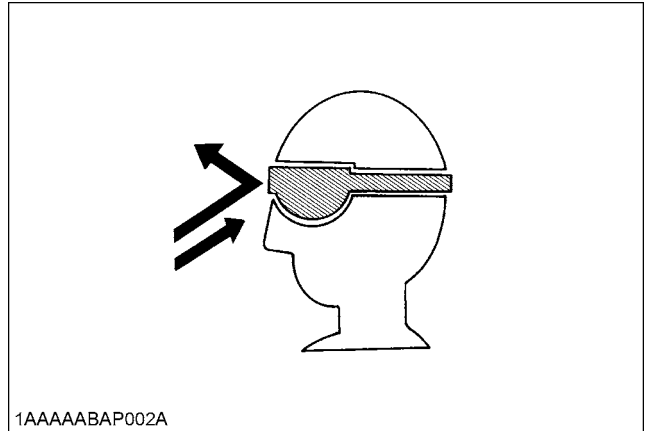

15. Securely support excavator with stands or suitable blocking before working underneath. For your safety, do not work under any hydraulically supported devices. They can settle, suddenly leak down, or be accidentally lowered.

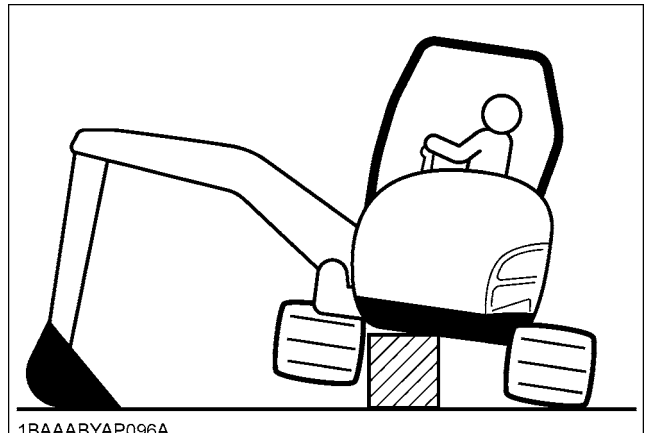

16. Do not dismantle the spring of the track tensioner. If dismantling is necessary, contact your KUBOTA dealer where the machine was purchased, or competent service shop. The assembly must be done according to the KUBOTA work shop manual (W.S.M.) for the product involved.
17. When lifting the machine itself with an attachment, place a safety block or safety post to prevent the machine from rolling over. Keep the lock lever for attachment control in the "LOCK" position.

18. Inspect ROPS / OPG for damage and if damage is found contact your KUBOTA dealer for repair.

19. KUBOTA does not use asbestos containing components and recommends against the use of such components.

Components containing asbestos should be handled in accordance with applicable regulations and industry practice.

DANGER, WARNING AND CAUTION LABELS

(1) Part No. RG158-5726-1
Keep away from fan and fan belt.

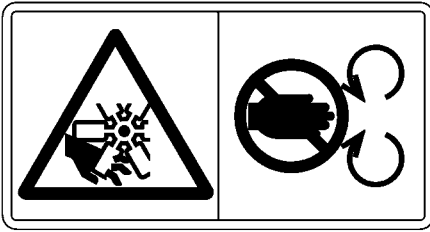

1BAAACDAP2050

(2) Part No. RG158-5721-1
Do not touch hot parts such as exhaust etc.

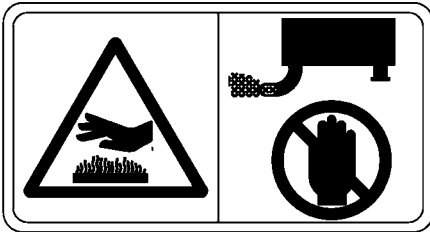

1BAAACDAP2060

(3) Part No. RG158-5718-1

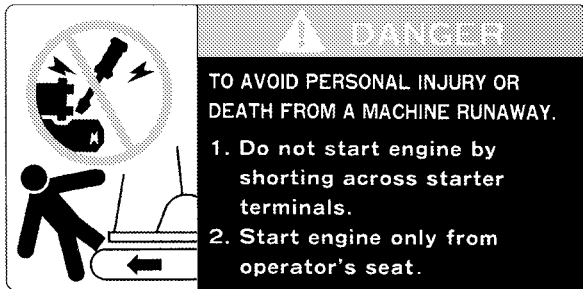

1BAAGAAP0250

(4) Part No. RG158-5727-1
Do not allow any persons within the working range.

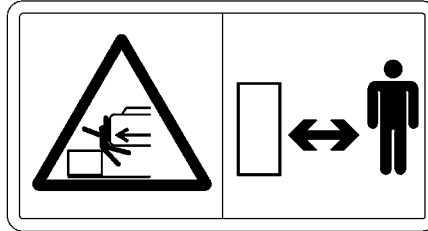

1BAAACDAP2080

(5) Part No. RG158-5737-1
Diesel fuel only No fire

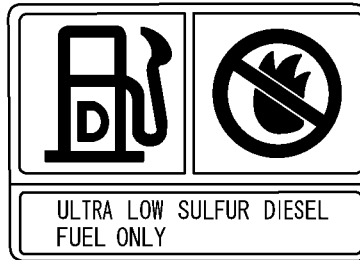

1BAAGAAP1810

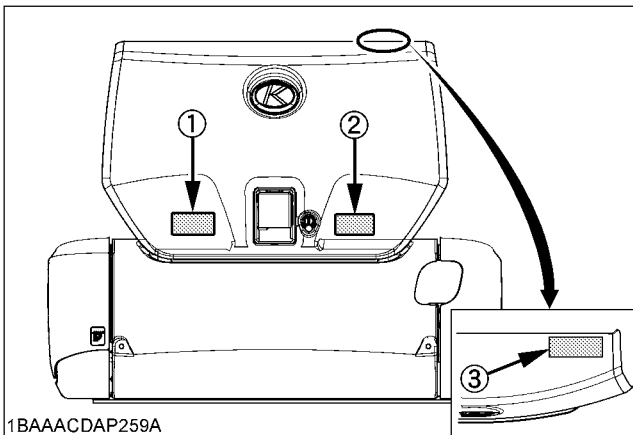

1BAAACDAP259A

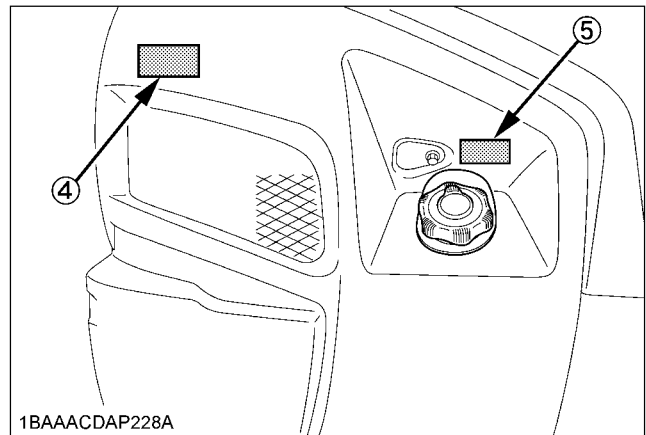

1BAAACDAP228A

(1) Part No. RG158-5824-1



1BAAACDAP251A

(2) Part No. RG158-5789-1
Keep away from fan and fan belt.



1BAAACDAP2030

(3) Part No. RG158-5764-1



1BAAACDAP249A

(4) Part No. RG158-5785-1
Do not touch hot parts such as exhaust etc.

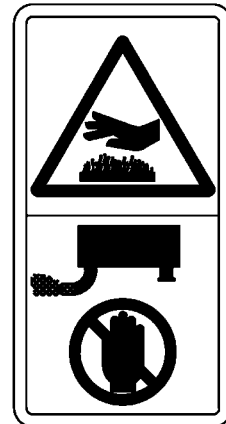

1BAAACDAP2040

(5) Part No. RG158-5765-1

DANGER EXPLOSIVE GASES
Cigarettes, flames or sparks could cause battery to explode. Always shield eyes and face from battery. Do not charge or use booster cables or adjust post connections without proper instruction and training.
KEEP VENT CAPS TIGHT AND LEVEL
POISON CAUSES SEVERE BURNS
Contains sulfuric acid. Avoid contact with skin, eyes or clothing. In event of accident flush with water and call a physician immediately.
KEEP OUT OF REACH OF CHILDREN

1BAAGAAAP0360

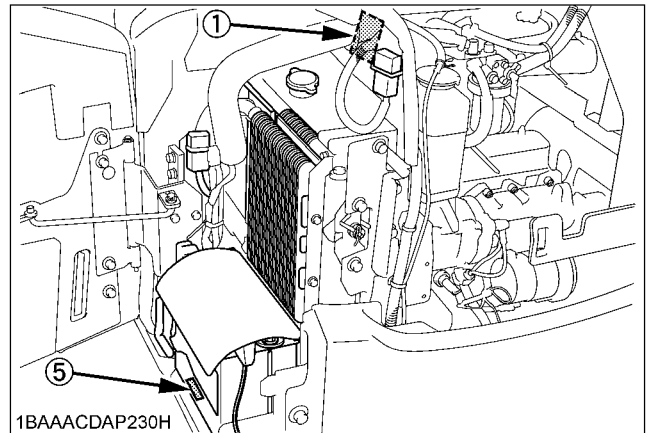

1BAAACDAP230H

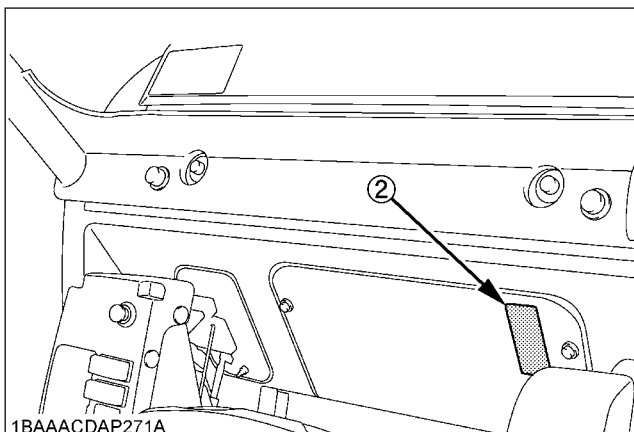

1BAAACDAP271A

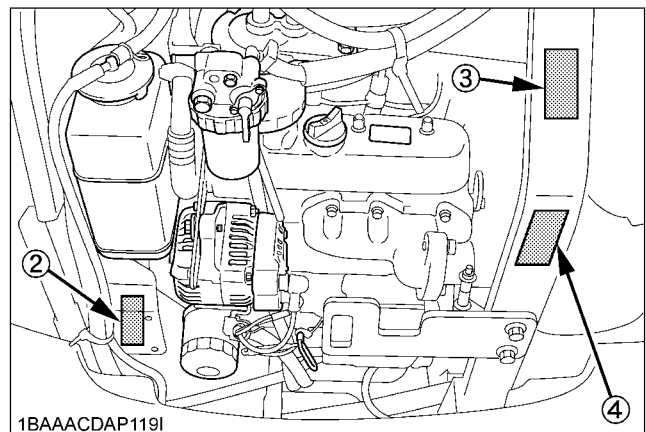

1BAAACDAP119I

(1) Part No. R2491-5796-1

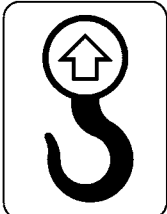

1BAAACDAP2100

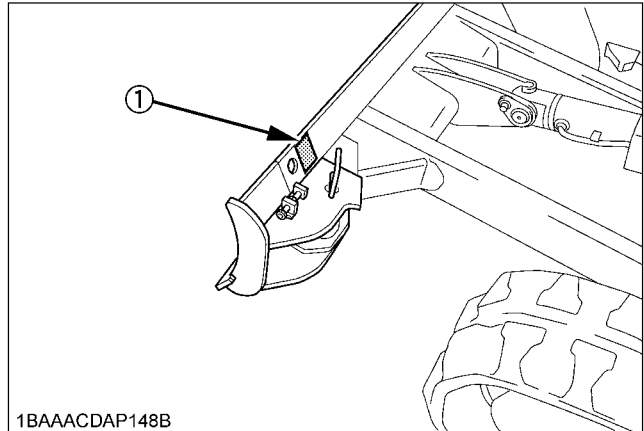

1BAAACDAP148B

(2) Part No. RG158-5822-1



1BAAGAAP0270

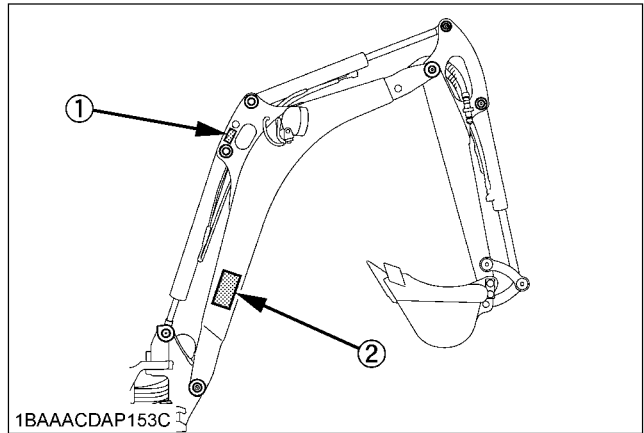

1BAAACDAP153C

(3) Part No. RG138-5791-1

Do not loosen the grease nipple completely or too quickly.

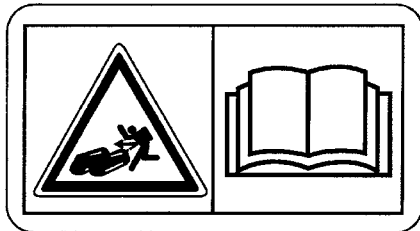

1BAABAMAP0010

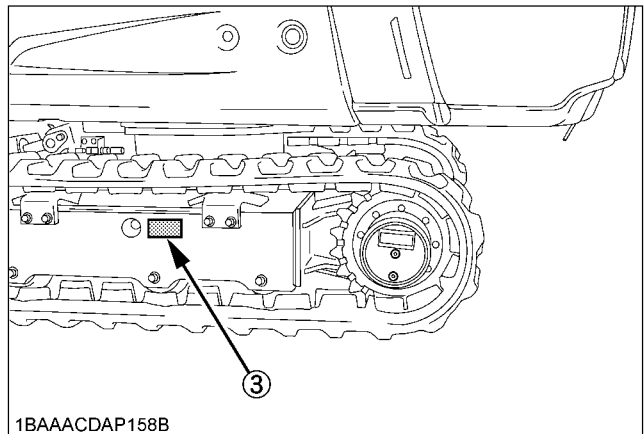

1BAAACDAP158B

(1) Part No. RG158-5728-1

CAUTION	TO AVOID PERSONAL INJURY:
	<ol style="list-style-type: none"> 1. Read and understand operators manual before attempting to start or operate the excavator. 2. Before starting engine, make sure all control levers are in neutral and the operating area is clear of all bystanders. 3. Never allow passengers on any part of the excavator while operating. 4. Know your work area before starting operation. <ul style="list-style-type: none"> • Check underground lines and cables. • Stay off slopes too steep for safe operation. • Check overhead clearance with electric wires. • Check for hidden holes, obstacles or drop-offs and overhangs. 5. Make sure all shields are in place and securely fastened. 6. Before dismounting from the machine, lower all attachment to the ground, stop the engine and remove the key. 7. Damaged ROPS must be replaced, not repaired or revised.
IMPORTANT	Never use boom, dipper, or bucket to hammer or beat sideways. Excavator is not intended for these usages.

1BAAACDAP242A

(2) Part No. RG158-5725-1

WARNING	
	<p>TO AVOID PERSONAL INJURY OR DEATH: Before moving the excavator, KNOW THE LOCATION OF THE DOZER BLADE. The excavator will travel in the direction of the dozer blade when drive levers are moved away from the operator.</p>
	<p>DO NOT OPERATE WITHOUT ROPS. YOU COULD BE CRUSHED.</p> <p>USE SEAT BELT</p>

1BAAACDAP252A

(3) Part No. RG158-5736-1

DANGER
<p>TO AVOID SERIOUS INJURY OR DEATH: Check overhead clearance with electric wires.</p>

1BAAACDAP243A

(4) Part No. RG158-5739-1

WARNING
<p>ATTACHMENT IMPACT HAZARD KEEP ATTACHMENT AWAY FROM CAB AND MACHINE FAILURE TO DO SO MAY RESULT IN SEVERE INJURIES OR DEATH OR DAMAGE TO THE BOOM/CYLINDER, HYDRAULIC HOSES OR THE CAB.</p>

1BAAACDAP244A

(5) Part No. RG109-5796-1

<p>1BAAACDAP2130</p>

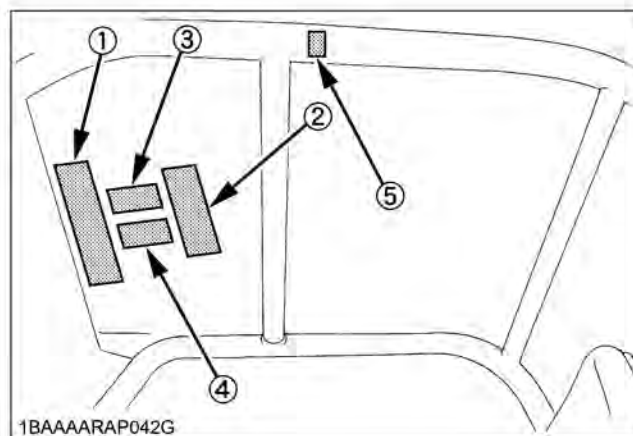

(1) Part No. RG058-5751-1 [KX016-4]

⚠ WARNING

TO AVOID PERSONAL INJURY OR DEATH:

- Do not move raised load over people.
- Do not raise loads to lift heights greater than those values mentioned in the lifting capacity tables.
- The values mentioned in the table are valid only on even, hard grounds. When lifting on soft ground, the machine can tilt over due to the fact that the load is concentrated only on one side of the machine.
- The table values are calculated on the end of the arm without the bucket. In order to find the allowable loads for machines with bucket, the bucket weight must be subtracted from the values in the table.
- Always always in standard track width 1240mm (50.8 in), except to pass through narrow space. Do not operate in narrow track width 900mm (35.0 in), to avoid risk of the excavator tipping over.

- The lifting capacities are based on ISO 10557 and do not exceed 75% of the static tilt load of the machine or 87% of the hydraulic lifting capacity of the machine.
- The strokes are as follows:
 - The load point corresponds to the front bolt part of the arm.
 - The machine positions are (1) over-front (blade down), (2) over-front (blade up), and (3) over-side.
 - The operating cylinder is the boom cylinder.
- The bucket of the excavator, the boom, the sling and other lifting accessories are taken into consideration for the loads.

LIFT POINT HEIGHT (m)	LIFTING CAPACITY OVER-FRONT BLADE DOWN				LIFTING CAPACITY OVER-FRONT BLADE UP				LIFTING CAPACITY OVER-SIDE TRACK WIDTH 1240mm				LIFTING CAPACITY OVER-SIDE TRACK WIDTH 900mm							
	Unit: t x kN (kg)				Unit: t x kN (kg)				Unit: t x kN (kg)				Unit: t x kN (kg)							
	LIFT POINT RADIUS (m)		LIFT POINT RADIUS (m)		LIFT POINT RADIUS (m)		LIFT POINT RADIUS (m)		LIFT POINT RADIUS (m)		LIFT POINT RADIUS (m)		LIFT POINT RADIUS (m)							
	1.0	1.5	2.0	2.5	3.0	1.0	1.5	2.0	2.5	3.0	1.0	1.5	2.0	2.5	3.0	1.0	1.5	2.0	2.5	3.0
2.5																				
2.0																				
1.0																				
0																				
-1.0																				
-1.5																				

Machine with ROPS canopy and rubber crawler, without bucket

1BAACDAP2570

(2) Part No. RG158-5751-3 [KX018-4]

⚠ WARNING

TO AVOID PERSONAL INJURY OR DEATH:

- Do not move raised load over people.
- Do not raise loads to lift heights greater than those values mentioned in the lifting capacity tables.
- The values mentioned in the table are valid only on even, hard grounds. When lifting on soft ground, the machine can tilt over due to the fact that the load is concentrated only on one side of the machine.
- The table values are calculated on the end of the arm without the bucket. In order to find the allowable loads for machines with bucket, the bucket weight must be subtracted from the values in the table.
- Always always in standard track width 1300mm (51.2 in), except to pass through narrow space. Do not operate in narrow track width 900mm (35.0 in), to avoid risk of the excavator tipping over.

- The lifting capacities are based on ISO 10557 and do not exceed 75% of the static tilt load of the machine or 87% of the hydraulic lifting capacity of the machine.
- The strokes are as follows:
 - The load point corresponds to the front bolt part of the arm.
 - The machine positions are (1) over-front (blade down), (2) over-front (blade up), and (3) over-side.
 - The operating cylinder is the boom cylinder.
- The bucket of the excavator, the boom, the sling and other lifting accessories are taken into consideration for the loads.

LIFT POINT HEIGHT (m)	LIFTING CAPACITY OVER-FRONT BLADE DOWN				LIFTING CAPACITY OVER-FRONT BLADE UP				LIFTING CAPACITY OVER-SIDE TRACK WIDTH 1300mm				LIFTING CAPACITY OVER-SIDE TRACK WIDTH 900mm							
	Unit: t x kN (kg)				Unit: t x kN (kg)				Unit: t x kN (kg)				Unit: t x kN (kg)							
	LIFT POINT RADIUS (m)		LIFT POINT RADIUS (m)		LIFT POINT RADIUS (m)		LIFT POINT RADIUS (m)		LIFT POINT RADIUS (m)		LIFT POINT RADIUS (m)		LIFT POINT RADIUS (m)							
	1.0	1.5	2.0	2.5	3.0	1.0	1.5	2.0	2.5	3.0	1.0	1.5	2.0	2.5	3.0	1.0	1.5	2.0	2.5	3.0
2.5																				
2.0																				
1.0																				
0																				
-1.0																				
-1.5																				

Machine with ROPS canopy and rubber crawler, without bucket

1BAACDAP246A

(3) Part No. RG158-5733-1

⚠ CAUTION

TO AVOID PERSONAL INJURY:

- Study control lever, pattern A and pattern B. Then choose the one which is most familiar.
- Position the pattern selector lever in either the lowered position (pattern A) or the upward position (pattern B).
- Engage lever lock to prevent accidental pattern change.
- Familiarize yourself with the pattern selected by operating slowly.

1BAAGAAP0170

(4) Part No. RG158-5753-1

⚠ CAUTION

TO AVOID PERSONAL INJURY:

Lock control lever before leaving compartment.

1BAACDAP247A

(5) Part No. RG158-5762-1

⚠ CAUTION

TO AVOID PERSONAL INJURY:

Mount and dismount safely when entering or leaving the operator's compartment.

- Maintain a three point contact with the steps and handrails.
- Face the machine.
- Never jump on or off the machine.
- Never attempt to mount or dismount a moving machine.
- Never use control levers as handles.

1BAACDAP248A

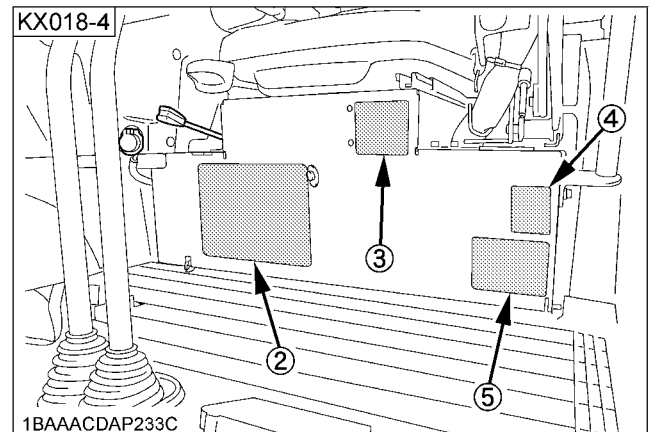
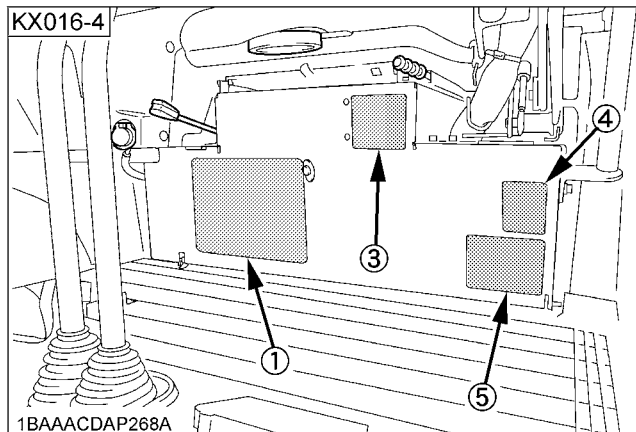

CARE OF DANGER, WARNING AND CAUTION LABELS

1. Keep danger, warning and caution labels, clean and free from obstructing material.
2. Clean danger, warning and caution labels with soap and water, dry with a soft cloth.
3. Replace damaged or missing danger, warning and caution labels with new labels from your KUBOTA dealer.
4. If a component with danger, warning and caution label(s) affixed is replaced with new part, make sure new label(s) is (are) attached in the same location(s) as the replaced component.
5. Mount new danger, warning and caution labels by applying on a clean dry surface and pressing any bubbles to outside edge.

DEALER SERVICE

Your KUBOTA dealer is always ready to help so that your excavator offers the best performance. After having carefully read this manual, you will realize that much of the routine maintenance can be done by yourself. Your KUBOTA dealer is responsible for servicing and the delivery of spare parts. When ordering spare parts from your KUBOTA dealer, always mention the serial number of the excavator and the engine.

Note these numbers right away in the supplied lines.

	Model	Serial No.
Excavator		
Engine		
Dealer's name (To be filled in through the owner)		

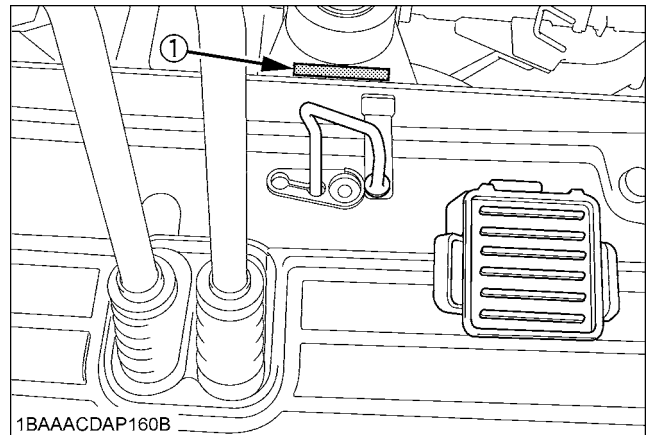
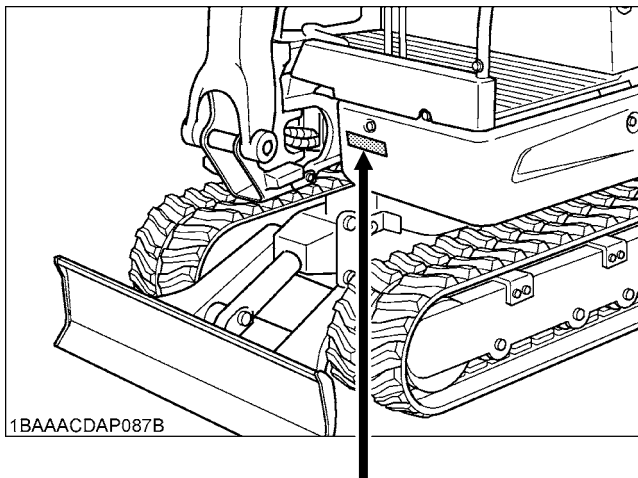

(1) Serial No.

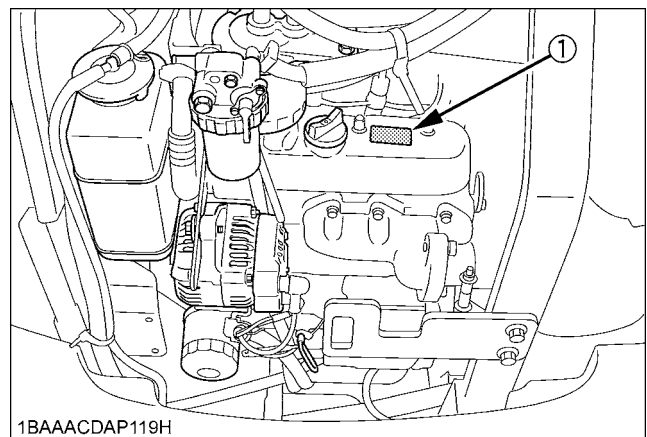

(1) Engine serial No.

KUBOTA Baumaschinen GmbH
STEINHAUSER STR. 100
66482 ZWEIBRÜCKEN GERMANY

MODEL

SERIAL No.

ENGINE No.

PRODUCT IDENTIFICATION NUMBER

1BAAACDAP262A

TECHNICAL DATA

		KUBOTA EXCAVATOR		
Model name		KX016-4	KX018-4	
Type		canopy		
Mass (without operator) kg		1490	1620	
Standard bucket	Volume (CECE) m ³	0.035	0.040	
	Width [with side cutter] mm	402 [422]	450 [474]	
	Weight kg	32.5	33.5	
Engine	Type (water cooled 4 cycle Diesel)	3 cylinder - diesel engine water cooled		
	Model name	D782-BH-5	D902-BH-2	
	Total displacement cm ³	778	898	
	Output (ISO 9249) kW (Hp)	9.6 (12.9)	11.8 (15.8)	
	Rated speed rpm	2300		
Performance	Swing speed rpm	9.1		
	Travel speed	fast km/h	3.8	4.0
		slow km/h	2.1	2.2
	Ground pressure kPa (kgf/cm ²)	25.5 (0.26)	25.5 (0.26)	
	Climbing angle % (deg)	27 (15)		
	Max. lateral sway % (degree)	18 (10)		
Dozer (width & height) mm	990 / 1240 x 230		990 / 1300 x 230	
Boom swing angle	Left rad (deg)	1.31 (75)		
	Right rad (deg)	1.05 (60)		
Pressure connection for attachments	Max. displacement L (US gal) / min	27	27.7	
	Max. pressure MPa (kgf/cm ²)	20.6 (210)	21.6 (220)	
Fuel tank capacity L	21			

NOTE :

- Above dimensions are based on the machine with JPN bucket.
JPN = made in Japan
- Above dimensions are based on the machine with rubber crawlers.
- Specifications subject to change without notice.

DESCRIPTION OF MACHINE PARTS

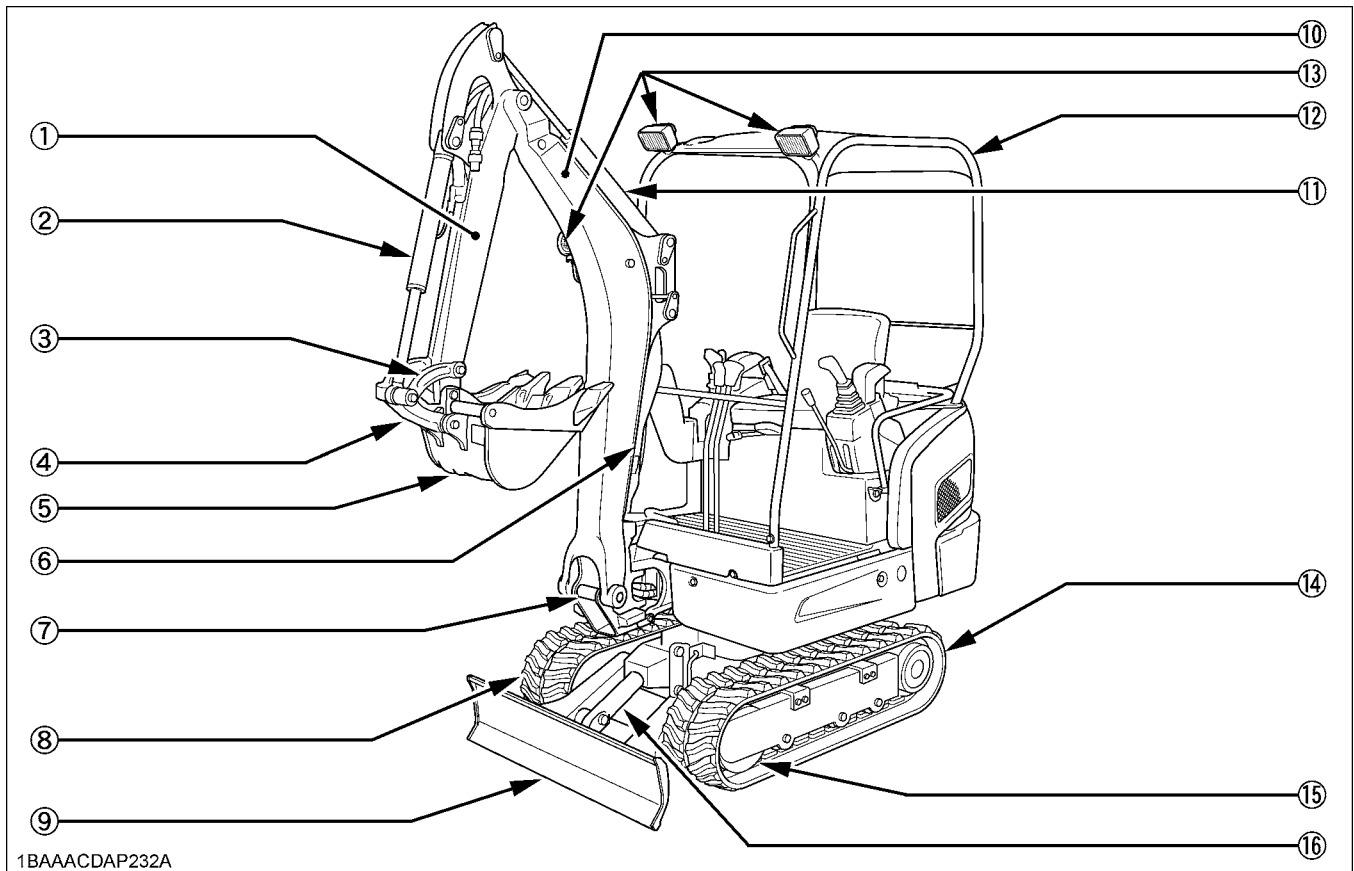

DEPICTED CONTENTS

- (1) Arm
- (2) Bucket cylinder
- (3) Bucket link 2 and 3
- (4) Bucket link 1
- (5) Bucket
- (6) Boom cylinder
- (7) Swing bracket
- (8) Track
- (9) Dozer blade
- (10) Boom
- (11) Arm cylinder
- (12) Canopy(Rops / OPG Top Guard)
- (13) Working light
- (14) Drive sprocket
- (15) Front idler
- (16) Dozer cylinder

INSTRUMENT PANEL AND CONTROL ELEMENTS

Switches

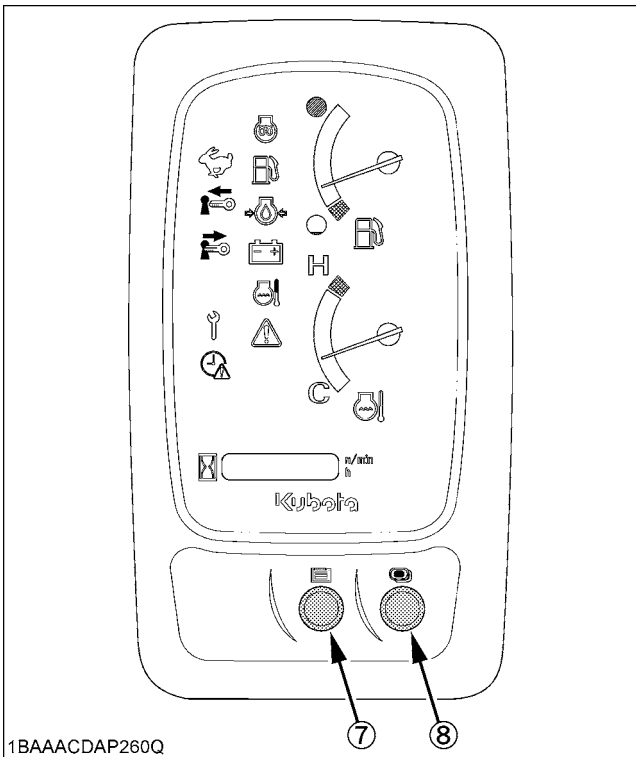
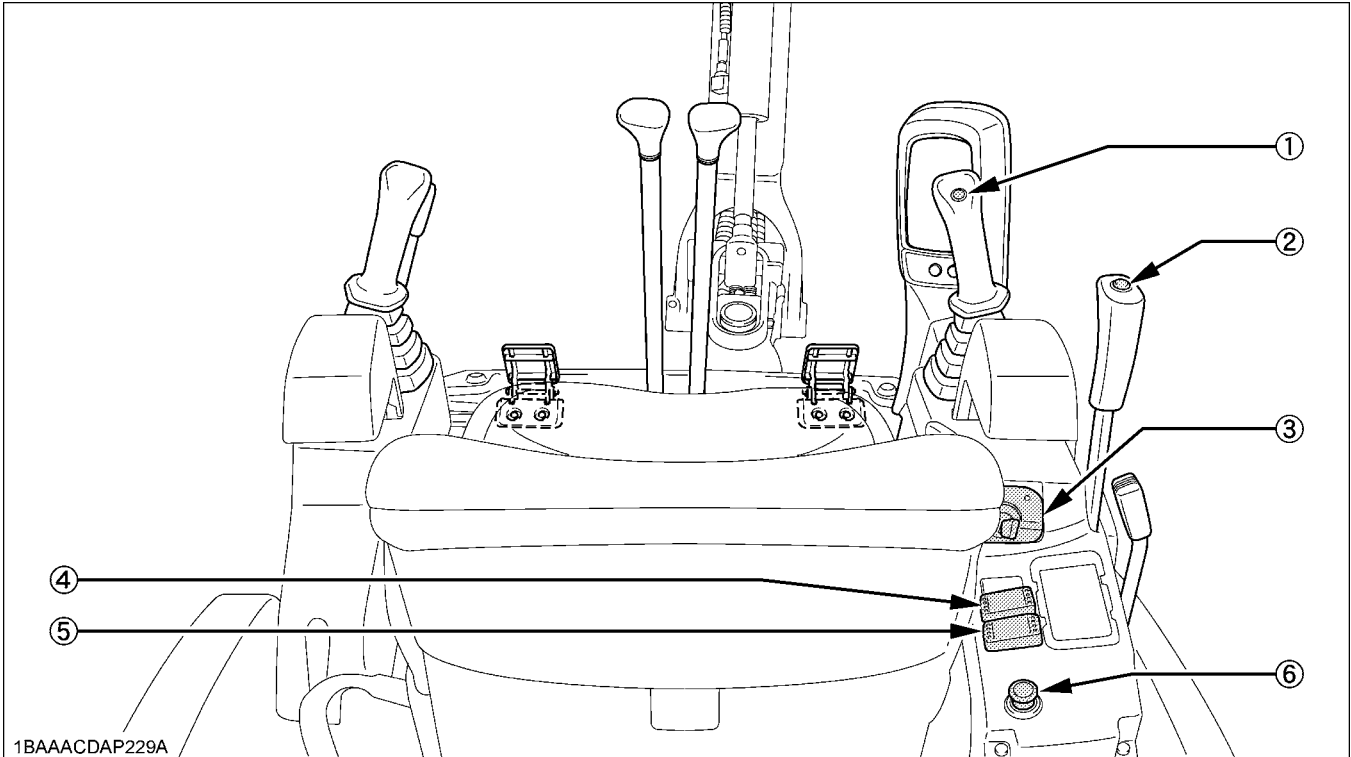

DEPICTED CONTENTS

- (1) Horn switch
- (2) Travel speed switch
- (3) Starter switch
- (4) Working light switch
- (5) Beacon switch
- (6) Engine stop knob
- (7) User setting switch (switch 2)
- (8) Display selector switch (switch 3)

■ Control Pedals and Levers

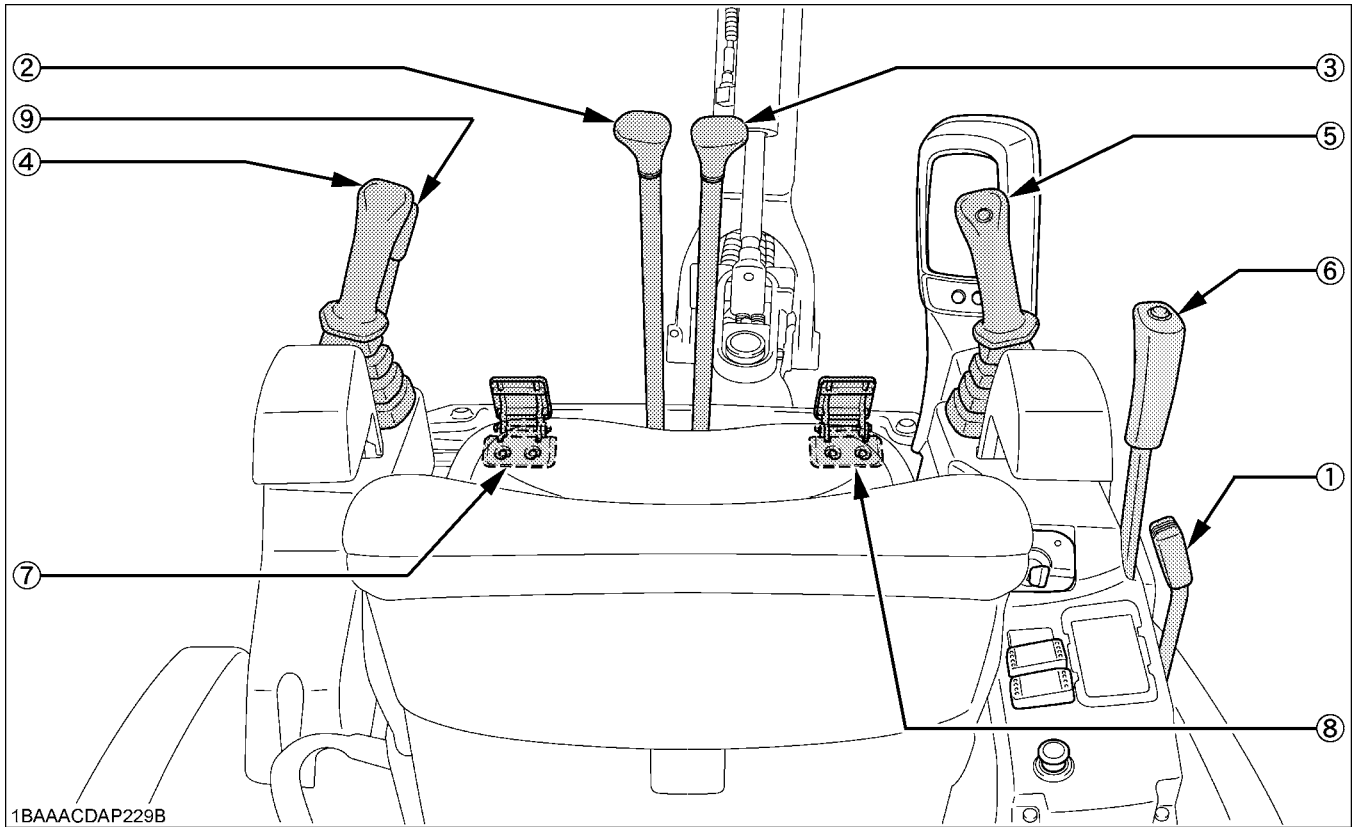

DEPICTED CONTENTS

- (1) Throttle lever
- (2) Drive lever (left)
- (3) Drive lever (right)
- (4) Attachment control lever (left)
- (5) Attachment control lever (right)
- (6) Dozer control lever
- (7) AUX port pedal
- (8) Boom swing pedal
- (9) Lock lever (Unload lever)*
- (10) Track width change lever
- (11) TPSS lever

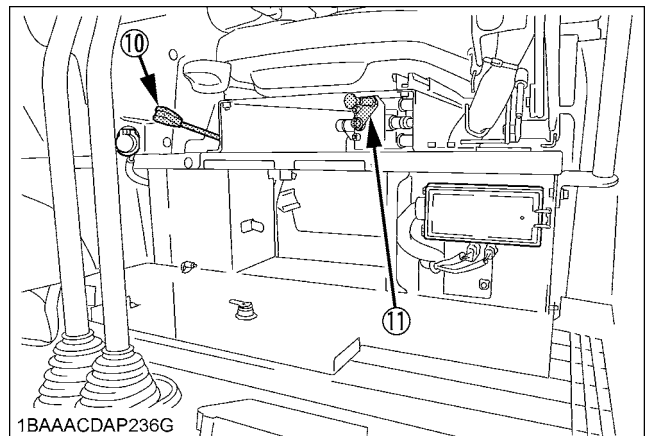

IMPORTANT :

* When the lock lever (unload lever) is pulled up, it prevents inadvertent machine movement.

■ Instrument Panel

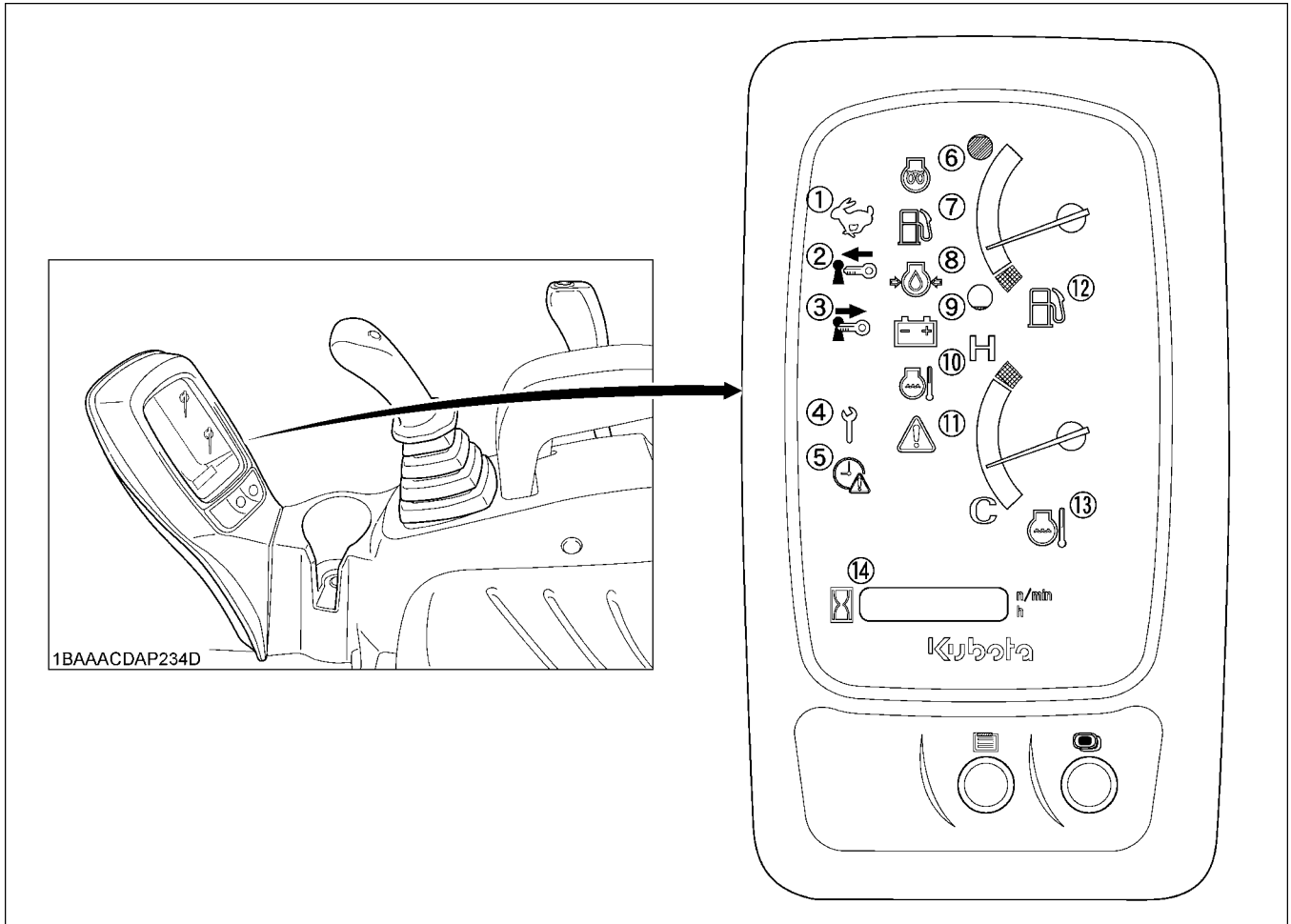

DEPICTED CONTENTS

- | | |
|---------------------------------|---------------------------------------|
| (1) Speed indicator lamp | (8) Engine oil pressure warning lamp |
| (2) Insert key lamp | (9) Battery charge lamp |
| (3) Pull out key lamp | (10) Coolant temperature warning lamp |
| (4) Periodic check lamp | (11) Warning lamp |
| (5) Clock setting request lamp | (12) Fuel gauge |
| (6) Glow lamp | (13) Coolant temperature gauge |
| (7) Remaining fuel warning lamp | (14) LCD display |

CHECKS BEFORE START

DAILY CHECKS

In order to avoid damage, it is important to check the condition of the excavator before starting.



CAUTION

To avoid personal injury:

- Do maintenance work on the excavator only on level ground with the engine off and the lock lever (unload lever) in the "Lock" position and key removed from machine. Then block the tracks with the blocks.

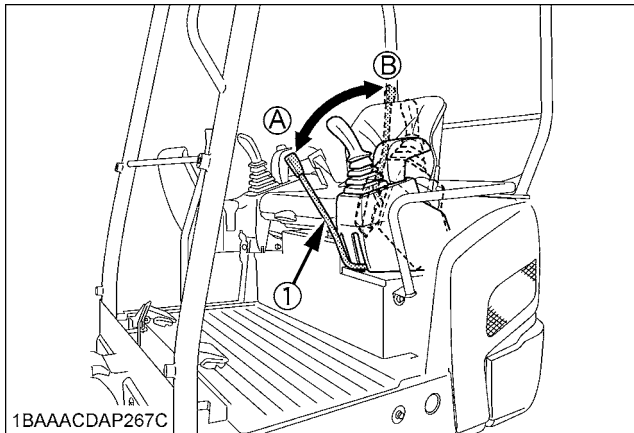

(1) Lock lever (Unload lever) (A) "Unlock"
(B) "Lock"

■ Working Light Switch

To turn on the working light, set the starter switch to the "RUN" and then the working light switch to the "ON" positions, respectively.

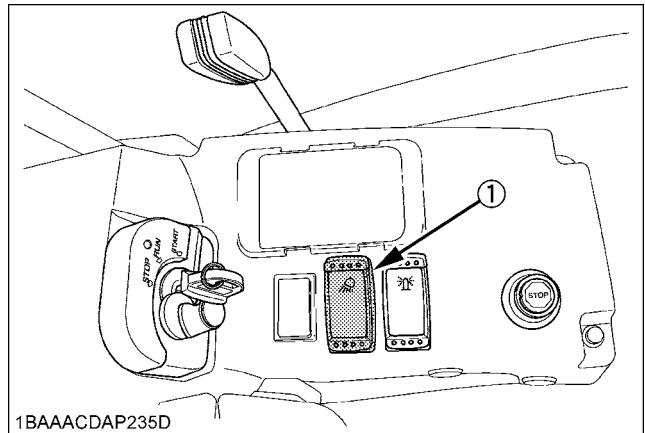

(1) Working light switch

Checks

Go around the excavator and check for visual damage and wear.

Check coolant level. (See regular checkpoints in the chapter on maintenance.)

Check fuel level.

Check engine oil level.

Check hydraulic fluid level.

Check air filter for clogging.

Check all control lamps, indicators, tachometer and hour meter.

Check the light system.

Check the seat belt and the ROPS/OPG Top Guard safety device.

Check the condition of the safety labels.

(See "DANGER, WARNING AND CAUTION LABELS" in "SAFE OPERATION".)

OPERATION OF THE ENGINE



CAUTION

To avoid personal injury:

- Read "SAFE OPERATION" at the beginning of this operator's manual.
- Obey the danger, warning and caution labels on the excavator.
- To avoid the danger of exhaust fume poisoning, do not operate the machine in a closed building without proper ventilation.
- Always start the engine from the operator's seat. Do not start the engine while standing next to the excavator. Before starting the engine, sound the horn to get the attention of persons standing nearby.

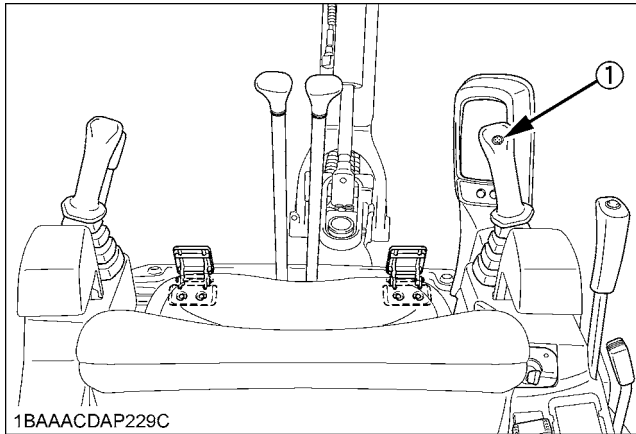

(1) Horn switch

IMPORTANT :

- Do not use starting fluid or ether.
- In order not to overload the battery and starter, avoid start-ups of more than 10 sec.
- When engine does not start in 10 sec., please wait 20 sec. or more, before attempting to restart.

STARTING THE ENGINE



CAUTION

To avoid personal injury:

- The operator should not depend solely on the warning lamps, but should always conduct the routine checks (see "MAINTENANCE").

Start the engine in the following manner:

1. Before starting the engine, make sure that all control levers are in the neutral positions.

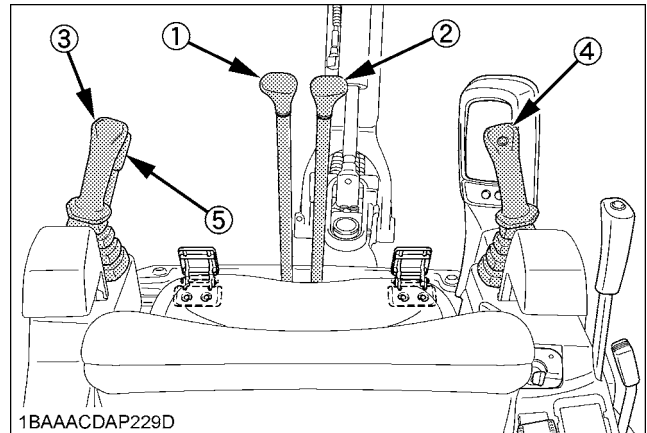

- (1) Drive lever (left)
- (2) Drive lever (right)
- (3) Attachment control lever (left)
- (4) Attachment control lever (right)
- (5) Lock lever (Unload lever)

2. Pull the lock lever (unload lever) all the way back. (lock position)
3. Put the throttle lever backward .
4. Insert the key into the starter switch and turn it to the position "Run". The glow lamp indicator will light up while the engine is preheated and will go out automatically after preheating is finished.

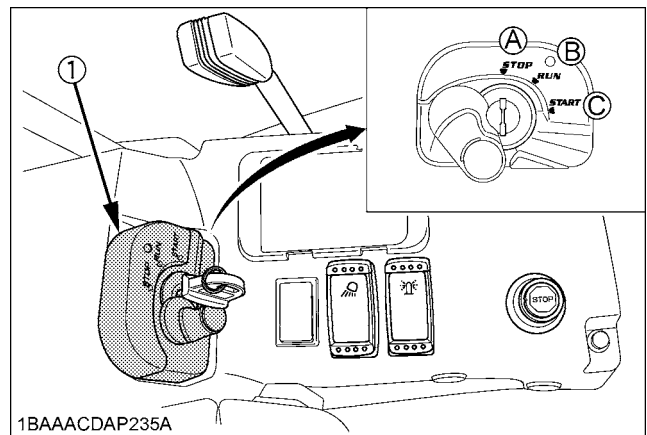

- (1) Starter switch
- (A) "STOP"
- (B) "RUN"
- (C) "START"

5. Turn the key to the position "START" and release after the engine has started.
6. Check if engine oil pressure warning lamp and battery charge lamp have gone out. Should a warning lamp still be lit up, stop the engine then remove the key and check for the cause.

■ Display Selector Switch

Press the display selector switch. The electronic meter's LCD display will change from one indication mode to the other.

Change the three-mode display according to your jobs.

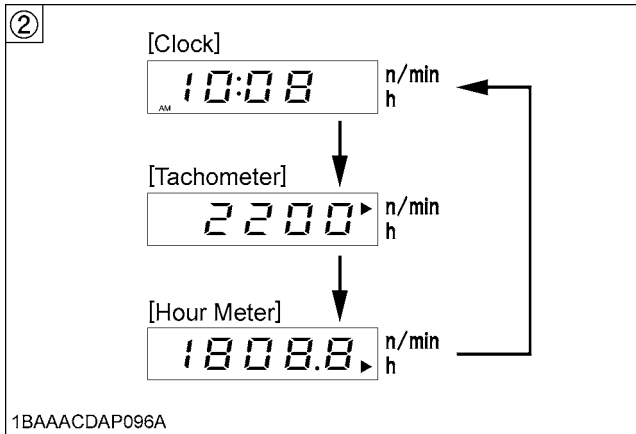
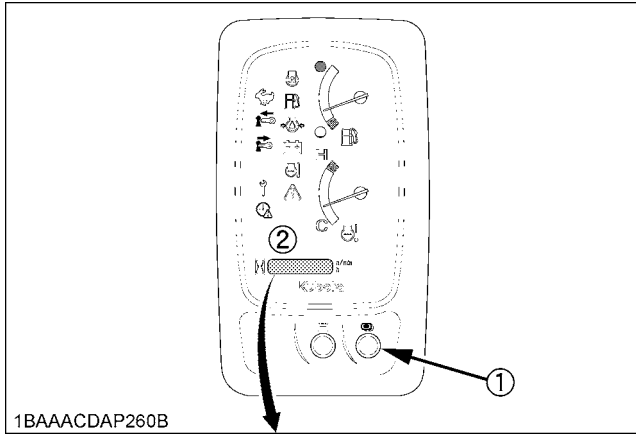

- (1) Display selector switch
- (2) LCD display

NOTE :

- With the starter key at the "STOP" position, press the electronic meter's display selector switch, and the LCD display shows the hour meter for 10 seconds.

◆ Setting the clock

[Selecting the clock setting mode]

1. Press the user setting switch (switch 2).
2. Select the clock setting mode by pressing the display selector switch (switch 3) and the clock setting request lamp "⌚" on the instrument panel lights up.

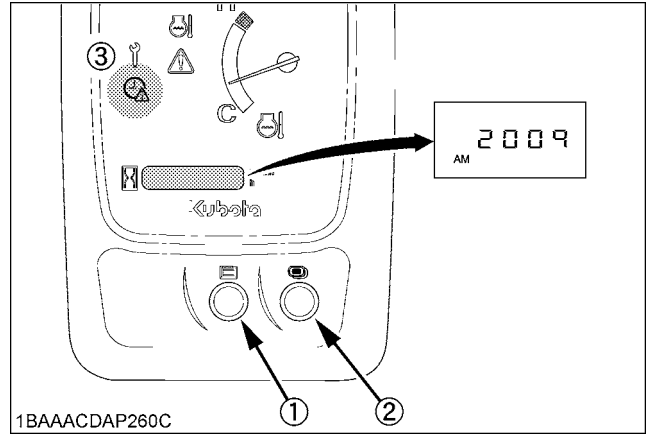

- (1) User setting switch (switch 2)
- (2) Display selector switch (switch 3)
- (3) Clock setting request lamp

NOTE :

- Press switch 3 for a long time and the year, month, day, hour and minute will be selected in this order.

[Setting the year]

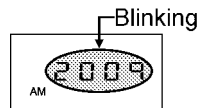

Press switch 2 and the numeric setting will be smaller.
Press switch 3 and the numeric setting will be larger.

Switch 2	Switch 3
2008	2010
↓	↑
2007	2009
↓	↑
2006	2008

NOTE :

- While setting the clock, the clock setting request lamp "⌚" on the instrument panel is blinking.

[Setting the month]

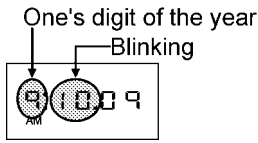

Press switch 2 and the numeric setting will be smaller.
Press switch 3 and the numeric setting will be larger.

Switch 2	Switch 3
10	11
↓	↑
9	10
↓	↑
8	9

[Setting the day]

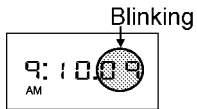

Press switch 2 and the numeric setting will be smaller.
Press switch 3 and the numeric setting will be larger.

Switch 2	Switch 3
09	11
↓	↑
08	10
↓	↑
07	9

[Changing the AM/PM system to the 24-hour system]

Select the AM/PM system or 24-hour system by pressing switch 3.

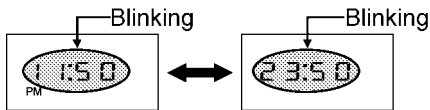

[Setting the hour]

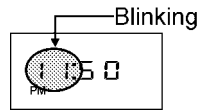

Press switch 2 and the numeric setting will be smaller.
Press switch 3 and the numeric setting will be larger.

Switch 2	Switch 3
11	12
↓	↑
10	11
↓	↑
9	10

[Setting the minute]

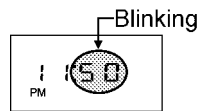

Press switch 2 and the numeric setting will be smaller.
Press switch 3 and the numeric setting will be larger.

Switch 2	Switch 3
50	52
↓	↑
49	51
↓	↑
48	50

If switch 3 is pressed for a long time, the new settings will be made.

NOTE :

- If the battery is disconnected, the clock setting request lamp "Ⓜ" (yellow) will blink for requesting the setting the clock.

■ Battery Charge Lamp

This warning lamp lights up if the charging system fails with the engine running. When the starter switch is turned to "RUN" with the engine off, the lamp lights up, and when the engine starts, the lamp goes out. If the lamp stays on with the engine running, stop the engine and check the fan belt.

NOTE :

- If there is disconnection or failure in the charging system when the key is turned to "RUN", the following symbol will appear.

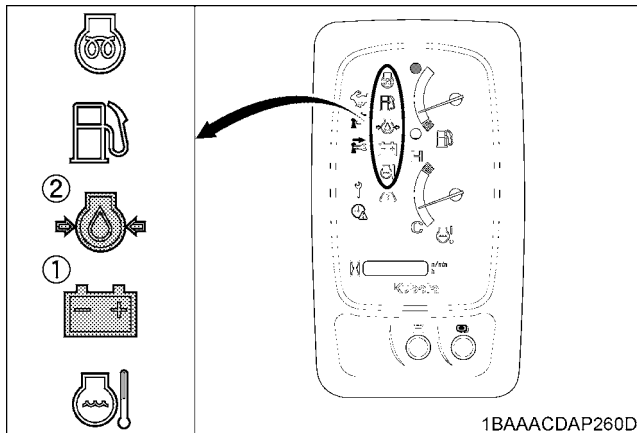

- (1) Battery charge lamp
(2) Engine oil pressure warning lamp

■ Engine Oil Pressure Warning Lamp

The engine oil pressure warning lamp lights up due to failure of the lubricating system with the engine running. When the starter switch is turned to "RUN" with the engine off, this lamp lights up, and when the engine starts, the lamp goes out. If the lamp stays on with the engine running, stop the engine and check the engine oil level.

NOTE :

- If there is disconnection, failure or breakdown in the lubricating system when the key is turned to "RUN", the following symbol will appear.

■ Glow Lamp

With the starter key at the "RUN" position, the engine's preheat status is indicated.

NOTE :

- When the starter switch is turned to the "RUN" position, the engine will be preheated for a given period of time and the lamp will turn on.
- The above indication appears momentarily when the engine is started, but it does not indicate trouble. (This is because the oil charge sensor output fluctuates when the engine is started.)
- The following symbol appears momentarily as the engine starts. This is not an error.

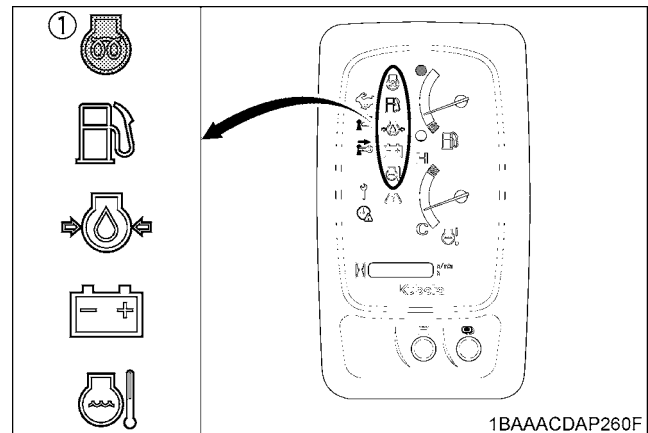

- (1) Glow lamp

■ LCD Display for Normal Operation

◆ Fuel gauge

CAUTION

To avoid personal injury:

- Before adding fuel, be sure to stop the engine.
- Be sure to keep open flame away from the machine. Otherwise a fire may result.

If the fuel in the tank goes below the prescribed level, the warning lamp will flash.

If this should happen during operation, refuel as soon as possible.

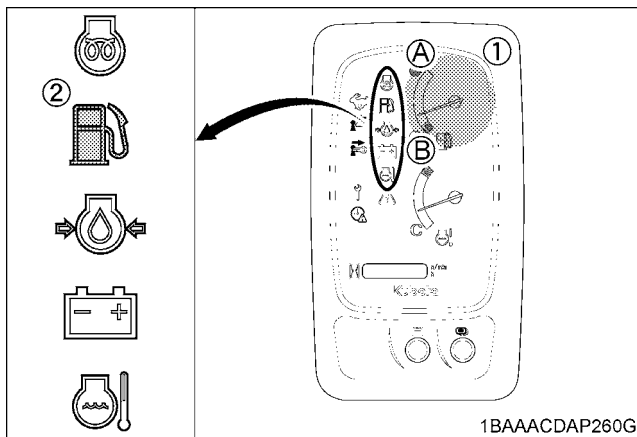

- (1) Fuel gauge (A) "FULL" (B) "EMPTY"
 (2) Remaining fuel warning lamp

IMPORTANT :

- If the fuel gauge indicator is near the "○", add fuel as soon as possible. If the indicator is near "○" and the machine operates on a slope, the engine may run out of fuel.

NOTE :

- To open the fuel cap, keep the starter key inserted.

◆ Coolant Temperature Gauge

CAUTION

To avoid personal injury:

- Do not open the radiator cap during or just after operation. Hot coolant may gush out and scald you. Wait for the coolant to cool down before opening the cap.

With the starter key at the "RUN" position, the cooling water temperature is indicated.

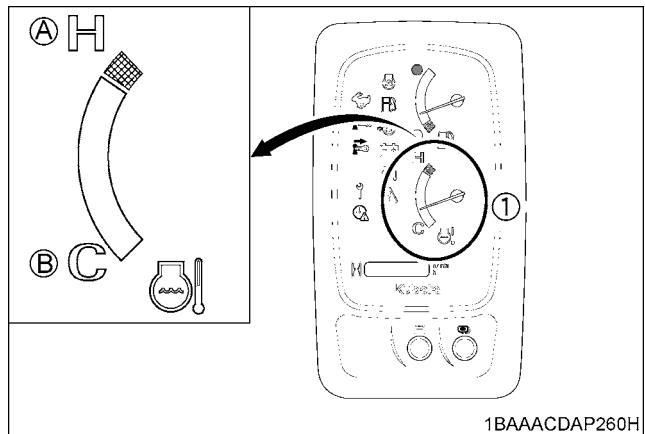

- (1) Coolant temperature gauge (A) "HOT" (B) "COOL"

◆ Hour-meter

Indicates the total operating hours of the machine.

How the indicator works

- The meter advances one hour after an hour of operation regardless of the engine rpm.

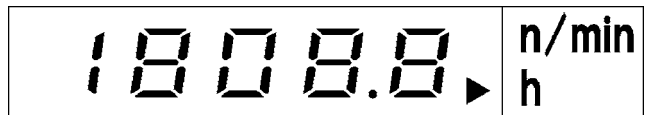

1BAAACDAP097A

◆ Engine tachometer

Indicates the current rpm of the engine.

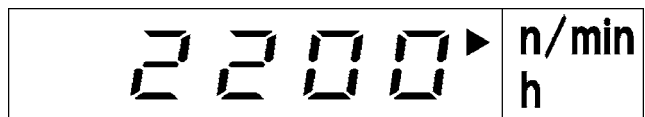

1BAAACDAP098A

NOTE :

- The LCD display may be illegible when viewed from a certain angle. This is not a display failure.

■ LCD Display for Warning

◆ Engine oil pressure warning lamp

The engine oil pressure warning lamp lights up due to failure of the lubricating system with the engine running. When the starter key is turned to "RUN" position with the engine off, this engine oil pressure lamp lights up, warning lamp blinks and when the engine starts, the lamps go out. If the lamp stays on with the engine running, stop the engine and check the engine oil level.

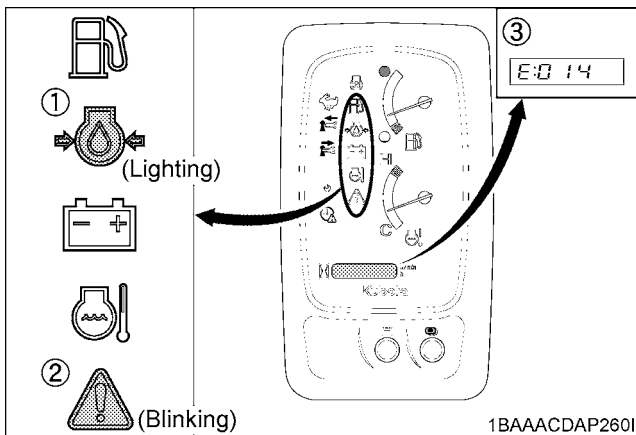

- (1) Engine oil pressure lamp
- (2) Warning lamp (red)
- (3) Warning message

◆ Battery charge lamp

This battery charge lamp lights up if the charging system fails with the engine running.

When the starter key is turned to "RUN" position with the engine off, the battery charge lamp lights up, warning lamp blinks and when the engine starts, the lamps go out. If the lamp stays on with the engine running, stop the engine and check the V-belt.

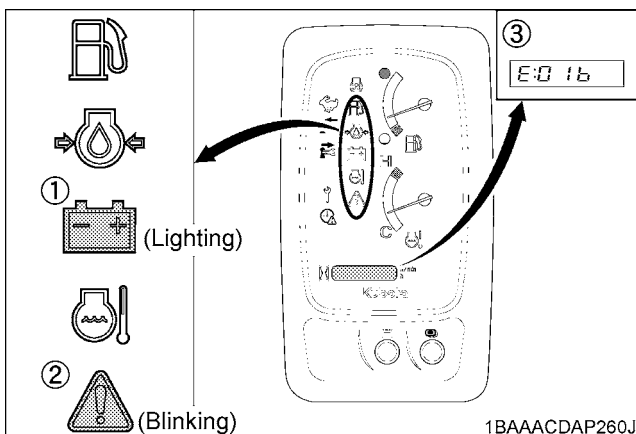

- (1) Battery charge lamp
- (2) Warning lamp (red)
- (3) Warning message

■ Warning Lamp

The warning lamp is used to indicate broken wire, short-circuit, fuel shortage and other problems.

IMPORTANT :

- Do not just look at the meter, but also carry out the inspection and correction accordingly.

NOTE :

- The warning lamp starts flashing in red if a serious problem occurs. If the system gets in warning signal, the warning lamp starts flashing in yellow.
- Warnings and errors are displayed and an alarm buzzer beeps.
- Let your KUBOTA dealer inform you of details concerning care and maintenance.

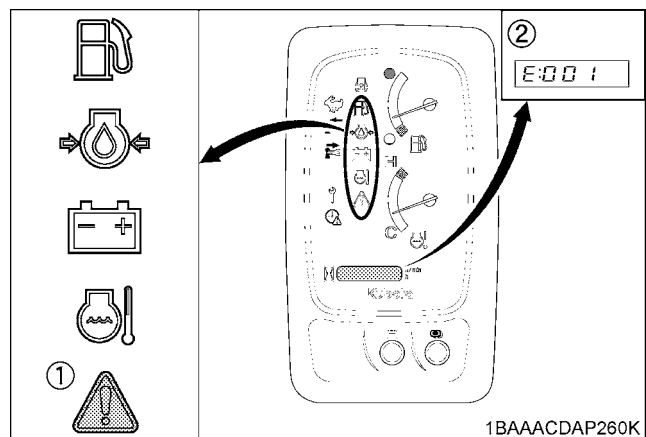

- (1) Warning lamp
- (2) Warning message

◆ Overheat warning

1. If the coolant temperature becomes elevated, the coolant temperature warning lamp blinks and the warning message (E : 015) appears on LCD display. The message fades out after a short time and the coolant temperature warning lamp blinks as long as the temperature remains elevated. Operate the machine only with reduced loads until the operating temperature is normal again.

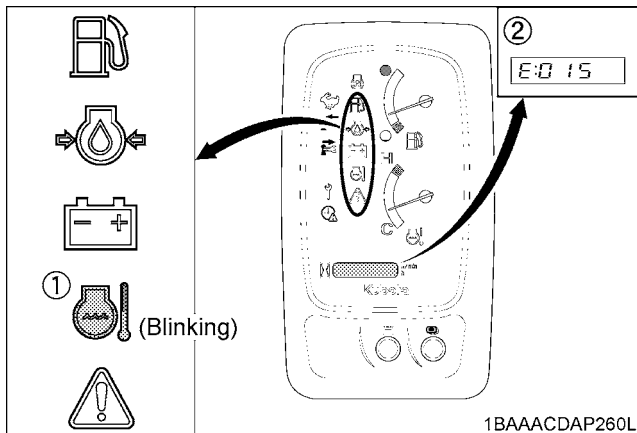

- (1) Coolant temperature warning lamp
 (2) Warning message

■ Checkpoints after Starting the Engine

After starting the engine, but before starting operation, check the following points:

1. Put the throttle lever down and let the engine idle for approx. five minutes. This allows the engine lubricant to warm up and penetrate every part of the engine.

NOTE :

- This idling is usually called "Warm-up".
2. Once the engine has warmed up, check:
 - the warning lamp "Engine oil pressure" has gone out.
 - the warning lamp "Battery charge" goes out when engine speed is increased.
 - the color of the exhaust is normal and no abnormal noises or vibrations are heard or felt.
 - no fluid is leaking from pipes or hoses.

◆ Should any following conditions occur, stop the engine immediately.

- The engine rpm's increases or decreases suddenly.
- Sudden abnormal noises are heard.
- Exhaust is black.
- Warning lamp for engine oil lights up during operation.

IMPORTANT :

- In these cases, the excavator must be checked and serviced by your local the KUBOTA dealer.

STARTING THE ENGINE UNDER COLD CONDITIONS



CAUTION

To avoid personal injury:

- Make sure that the lock lever (unload lever) is in the lock position during warm up.

Start the engine in the following manner;

1. Pull the lock lever (unload lever) all the way back (lock position).
2. Turn the starter switch to the position "RUN" (glow position) and keep until the indicator lamp has gone out.
3. Move the starter switch to the position "START"; to crank and start engine.
4. Release the starter switch after the engine has started; it will automatically return to the position "RUN".

IMPORTANT :

- Let the engine warm up after start-up for approx. 10 minutes under no load conditions. If the hydraulic fluid temperature is too low, the operation will be affected. Do not operate the excavator under full load until the engine has sufficiently warmed up.

■ Precautions in case of Overheat



CAUTION

To avoid personal injury:

- Do not open the radiator cap during and just after operation. Hot coolant may gush out and burn you. Wait long enough until the radiator cools down.

If by any chance coolant gets heated up to the boiling point or over (overheated), take the following steps.

1. Stop operation in a safe position.
(Disconnect the engine's load.)
2. Do not stop the engine suddenly. Keep the engine idling under no load for about 5 minutes and then turn it off.
3. Keep yourself enough away from the machine for another 10 minutes or while steam is emitting.
4. Make sure there is no hazard of getting burned. Pinpoint and remove the cause of overheat, referring to "TROUBLESHOOTING". Then restart the engine.

STOPPING THE ENGINE



WARNING

To avoid personal injury or death:

- Do not keep the bucket or dozer in the lifted position, as a person could accidentally touch the levers and cause serious accidents.

1. After slowing the engine to idle, turn the key to "STOP".
2. Remove the key.
3. Pull the lock lever (unload lever) to "LOCK" position.

■ Engine Stop Knob



CAUTION

To avoid personal injury:

- Keep hands away from rotating parts.

IMPORTANT :

- Be sure to return the stop knob to former position after the engine stops.

The engine stops when the starter key is turned off. If the engine does not stop, pull the stop knob to stop the engine.

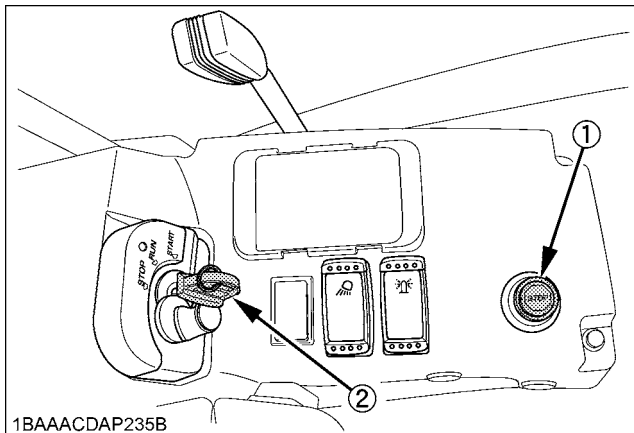

- (1) Stop knob
(2) Starter key

STARTING WITH AN AUXILIARY BATTERY



CAUTION

To avoid personal injury:

- Battery gases can explode. Do not smoke and keep sparks and flames away.
- Do not start the engine with an auxiliary battery if excavator battery is frozen.
- Do not connect the black jumper cable to the negative (-) terminal of the excavator battery.

■ Observe Following Guidelines when Starting with an Auxiliary Battery

1. Bring the helping machine with the same battery voltage as near as possible to the machine. THE MACHINES MUST NOT COME IN CONTACT WITH EACH OTHER.
2. Bring the levers and pedal of both machines in the neutral position.
3. Wear eye protection and rubber gloves.
4. Ensure the vent caps are securely in place (if equipped).
5. Connect the terminal of the red jumper cable with the plus (+) terminal of the low battery and connect the other end of the cable to the plus (+) terminal of the auxiliary battery.
6. Connect the black negative cable to the minus (-) terminal of the auxiliary battery.
7. Connect the other end of the black cable (coming from the auxiliary battery) to the machine frame as far away as possible from the low battery.
8. Start the engine of the helping machine and let it run for a while. Start the machine with the low battery.
9. Disconnect the jumper cables in the reverse sequence.

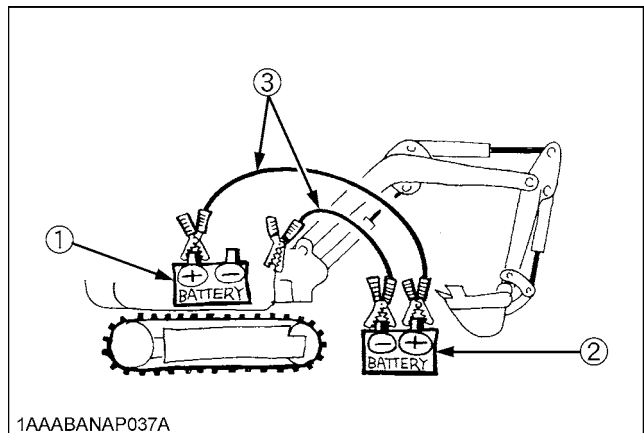

- (1) Low battery
(2) Auxiliary battery
(3) Jumper cables

IMPORTANT :

- This excavator has a negative (-) ground 12 Volt starting system.
- Only use the same voltage when using an auxiliary battery.
- Using a higher voltage will cause serious damage to the electrical system. When using an auxiliary battery, only the compatible (same) voltage is permissible.

EXCAVATOR OPERATION

RUNNING-IN OF THE NEW EXCAVATOR

The operation and care of the new excavator influences its life span. Your new excavator has been carefully checked and tested before leaving the factory. In spite of this, all movable components must run-in during the first 50 work hours. Do not work with full rpm's and full loads during this period. It is most important to run-in your excavator properly in order to achieve its full performance and longevity. During the running-in, the following points should be adhered to in all cases.

■ Do not Work with Full Engine Rpm's or Full Loads during the First 50 Working Hours

- Let the engine warm up sufficiently in the cold season.
- Do not let the engine rev-up more than necessary.

■ Oil Change in the Run-in Stage

The lubrication oil plays a specific and important role during the run-in phase of the excavator. The numerous movable parts are not yet run-in, so many fine metal particles are generated and cause damage and shorten the life of many components. Pay attention to the oil-change intervals and complete them sooner than later. See "REGULAR CHECKS AND MAINTENANCE WORK" section for more details on the oil-change intervals.

STARTING

1. Wear the seat belt.

■ Seat Belt



WARNING

To avoid personal injury or death:

- Always use the seat belt with a ROPS/OPG Top Guard protection structure. Adjust the seat to the optimal position and buckle up.

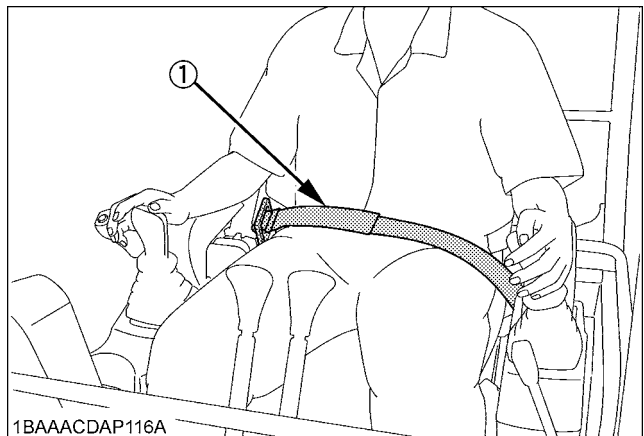

(1) Seat belt

2. Adjusting the Operator's Position.

■ Operator's Seat



CAUTION

To avoid personal injury:

- Make sure that the seat is completely secured after each adjustment.
- Do not allow any person other than the driver to ride on the excavator.

[KX016-4]

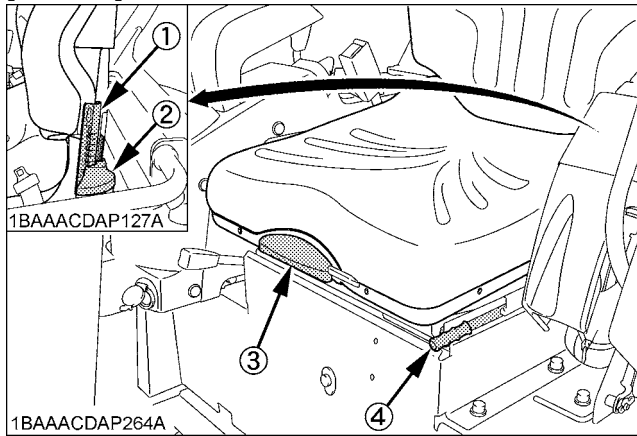

- (1) Weight indicator
- (2) Lever
- (3) Backrest adjustment lever
- (4) Horizontal seat adjustment lever

◆ Horizontal seat adjustment (seat stand-off)

Pull the horizontal seat adjustment lever up and move the seat to the desired position by moving it forward or back, then release the lever.

IMPORTANT :

- Check that the seat is locked into place.

◆ Spring adjustment (driver's weight)

1. The seat can be set to the weight of the driver with the lever. The weight indicator is provided as an adjustment aid.
2. Pressing down the lever increases the spring tension (suitable for heavier operators), pulling the lever upward reduces spring tension (for lighter operators).
3. Adjust the seat so that a comfortable cushioning is achieved.

◆ Backrest adjustment

Take the load off the backrest and pull up the backrest adjustment lever. Set the backrest to the desired sitting position and release the lever. The backrest should be adjusted so that the operator can safely operate the control levers with the back resting completely on the backrest.

[KX018-4]

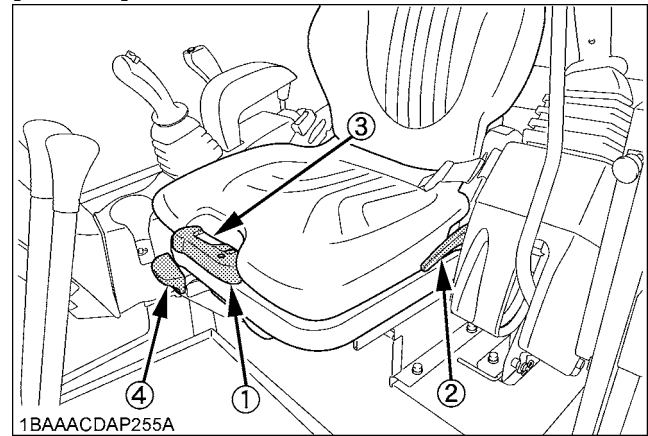

- (1) Backrest adjustment lever
- (2) Weight indicator
- (3) Spring adjustment grip
- (4) Horizontal seat adjustment lever

◆ Horizontal seat adjustment (seat stand-off)

Pull the horizontal seat adjustment lever up and move the seat to the desired position by moving it forward or back, then release the lever.

IMPORTANT :

- Check that the seat is locked into place.

◆ Spring adjustment (driver's weight)

1. The seat can be set to the weight of the driver with the lever. A weight indicator is provided as an adjustment aid.
2. Sit down on the driver's seat.
3. Swing out spring adjustment grip by 90 degrees.
4. Use up and down pumping movements to change the spring tension until your own body weight is shown in the weight display.

IMPORTANT :

- Adjust the seat until the marker arrow is in the centre of the weight display.

◆ Backrest adjustment

Take the load off the backrest and pull up the backrest adjustment lever. Set the backrest of the desired sitting position and release the lever. The backrest should be adjusted so that the operator can safely operate the control levers with the back resting completely on the backrest.

- After starting the engine, bring the lock lever (unload lever) into the "Unlock" position to use drive lever or control lever for front attachments.

■ Lock Lever (Unload Lever)



CAUTION

To avoid personal injury:

- To avoid injuries, check safety features all around the excavator.

NOTE :

- With the lock lever (unload lever) pulled down, the engine fails to start.

If you try to start the engine with the key with the lock lever (unload lever) down, the "▲" lamp (yellow) starts flashing.

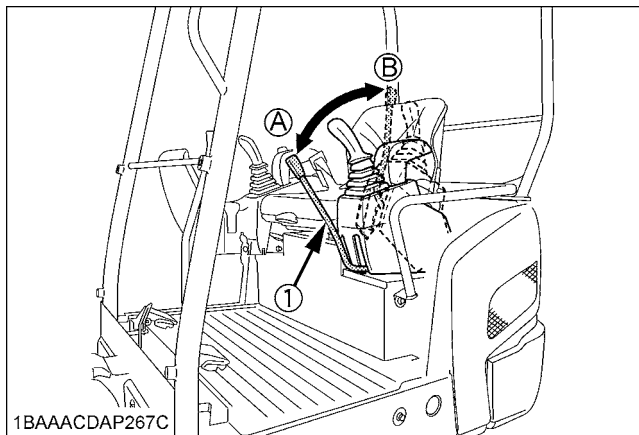

1BAAACDAP267C

(1) Lock lever (Unload lever) (A) "Unlock" (B) "Lock"

■ Working Light Switch

When the starter switch is in position "RUN", the light(s) will be switched on by pressing the switch.

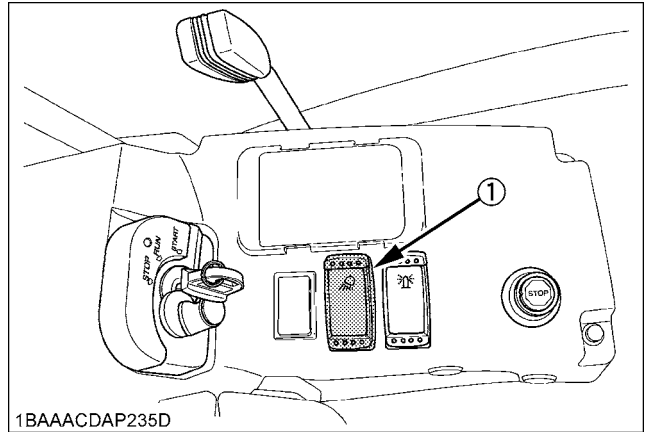

1BAAACDAP235D

(1) Working light switch

◆ Night operation



CAUTION

To avoid personal injury:

- Visibility is reduced in darkness, therefore the work light alone may not be enough. In which case, prepare additional stationary artificial lighting, observe safety rules as well as special regulations for night work.

■ Beacon Light Switch

It is equipped only with the switch (including the coupler for connecting in a rear left speaker).

Since it isn't equipped with the beacon main part, please post - install, when required.

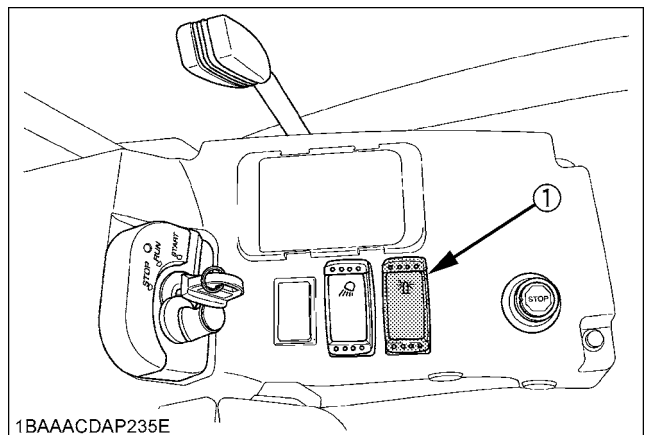

1BAAACDAP235E

(1) Beacon light switch

OPERATION OF TRACK WIDTH CHANGE



WARNING

To avoid personal injury or death:

- Operate always in standard track width 1240 mm [KX016-4] / 1300 mm [KX018-4], except to pass through narrow space. Do not operate in narrow track width 990 mm, or the risk of the excavator tip-over increases.

Pull up the track width change lever (1). The track width increases from 990 mm to 1240 mm [KX016-4] / 1300 mm [KX018-4].

Push down the track width change lever (1), and the track width reduces from 1240 mm [KX016-4] / 1300 mm [KX018-4] to 990 mm.

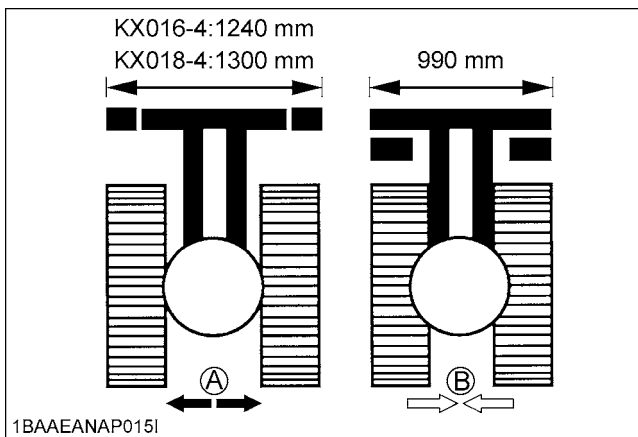
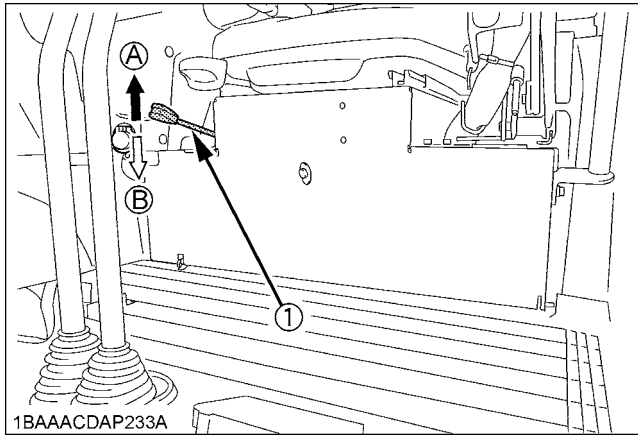

(1) Track width change lever

(A) "Increase"
(B) "Reduce"

OPERATION OF THE DOZER

1. To raise the dozer, pull back the control lever. Pushing the control lever forward, lowers the dozer.

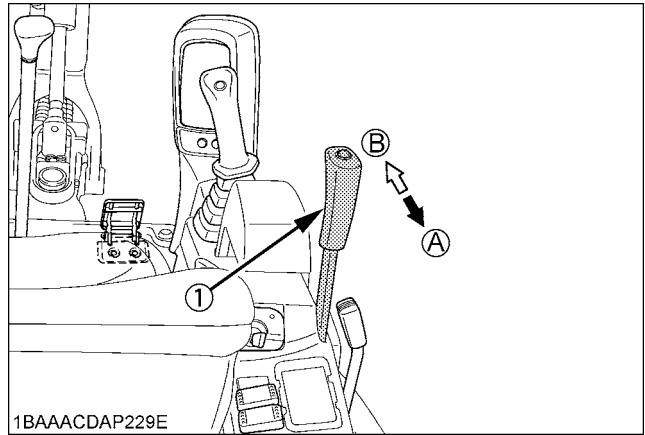

(1) Dozer control lever

(A) "Raise"
(B) "Lower"

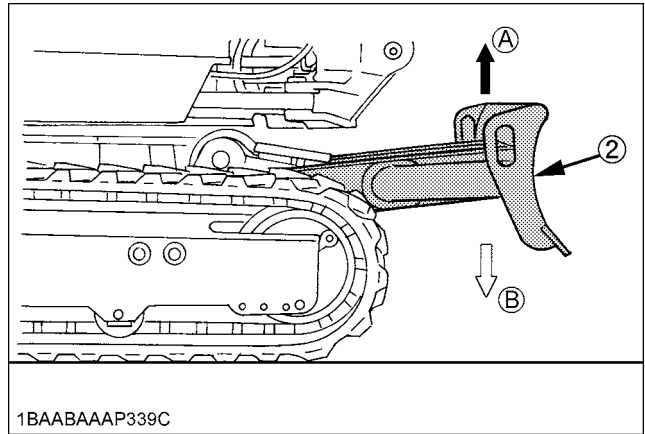

(2) Dozer

(A) "Raise"
(B) "Lower"

2. While undertaking earth moving work, control both drive levers with the left hand and the dozer control lever with the right hand.

■ Adjustment of the Dozer Width

In order to change from standard width to narrow width:

1. Pull out the locking pin (2) and rotate the extension dozer (1).
2. Set per the illustration below and insert locking pin (2).
3. Perform for both sides.

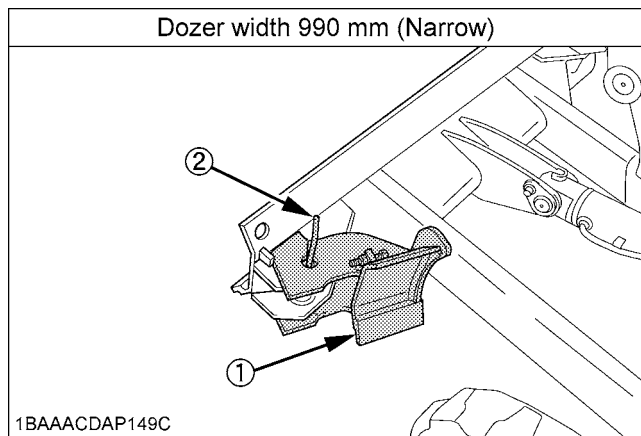
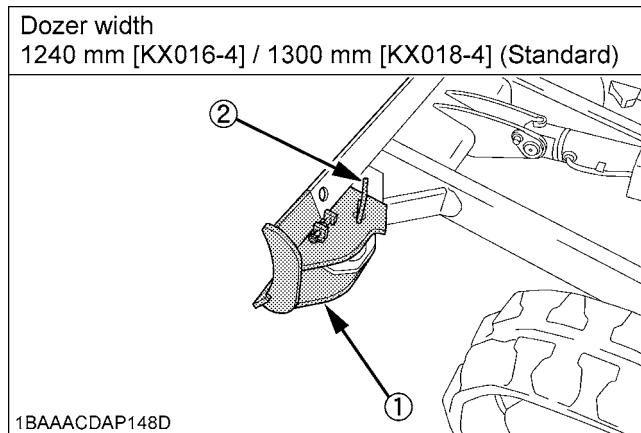

- (1) Extension dozer
(2) Fixing pin

DRIVING

⚠ WARNING

To avoid personal injury or death:

- Before starting the engine, make sure that no one is near the excavator.
- Before operating the excavator, check the track direction. (Front idler and dozer blade to the front of the excavator).

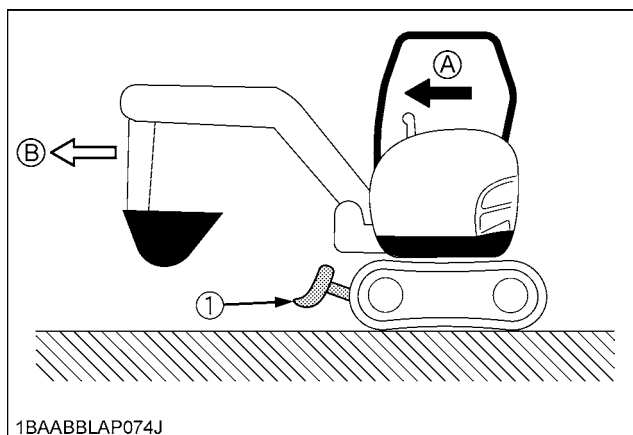

- (1) Dozer blade
(A) Direction of operation of drive levers
(B) Direction of travel

- Use extra caution when traveling across a slope or working sideways on a slope.

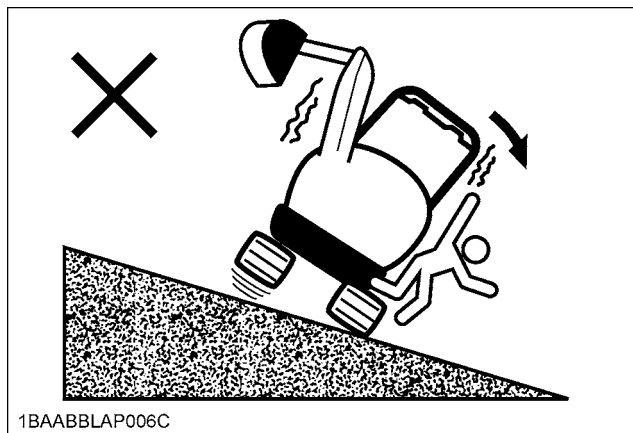

- Take precautions against tipping over. Stay away from steep slopes and embankments. Do not swing the bucket downhill. Lower the dozer blade when digging. Keep the bucket as low as possible while driving uphill. Turn slowly on slopes (at reduced speed). Do not place the excavator near the edges of trenches and banks, as the earth can give away due to the weight of the excavator.
ALLOWABLE CLIMBING ANGLE : 36 % (20 deg.)
ALLOWABLE ANGLE CROSS : 27 % (15 deg.)

● Recommended technique for working on a slope.

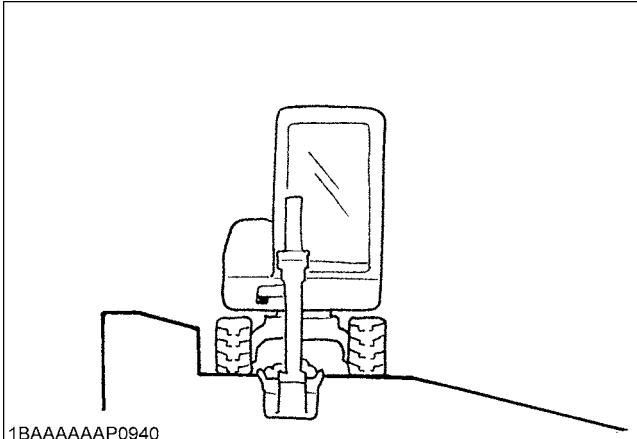

1BAAAAAAP0940

1. Adjust the engine speed from idling to an intermediate speed.
2. Unlock the lock levers and pull in the bucket and hold the bucket about 20 to 40cm above the ground.

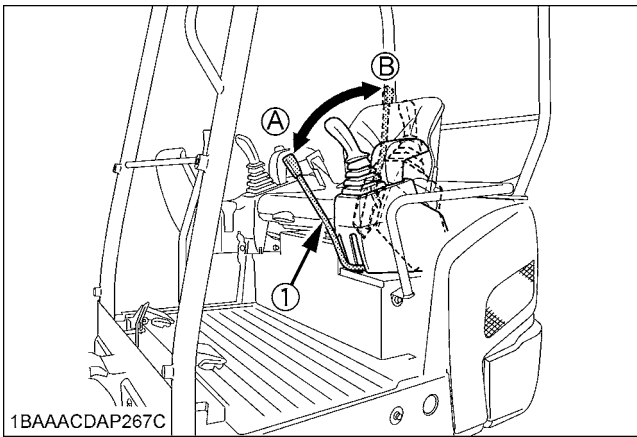

1BAAACDAP267C

- (1) Lock lever
(A) "Unlock"
(B) "Lock"

3. Activate the dozer control lever to raise the dozer.

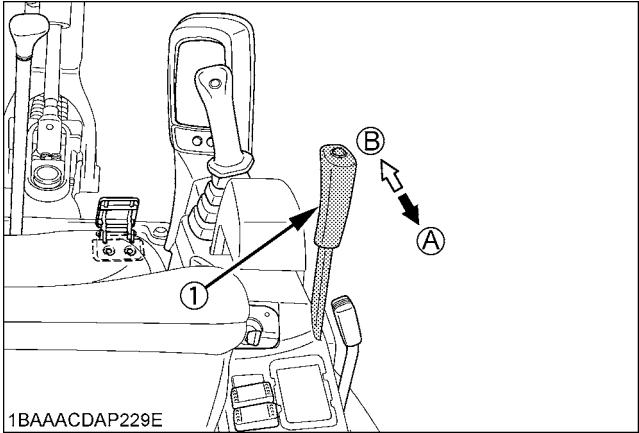

1BAAACDAP229E

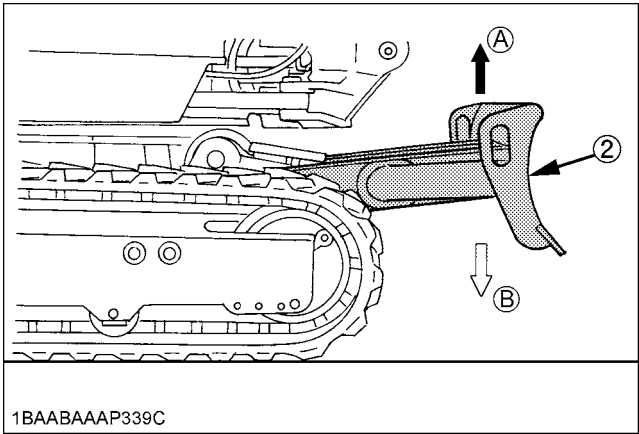

1BAABAAAP339C

- (1) Dozer control lever
(2) Dozer
(A) "Raise"
(B) "Lower"

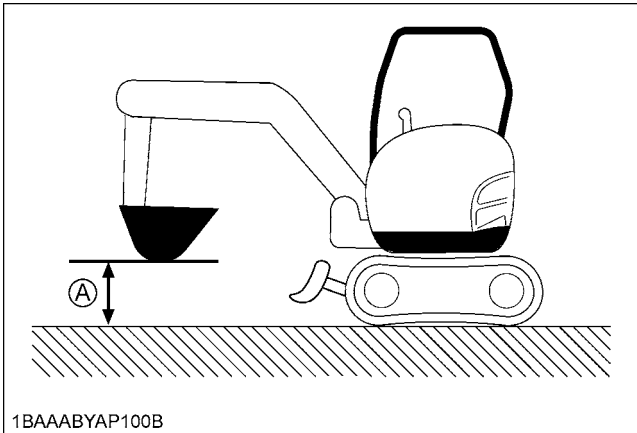

1BAAABYAP100B

- (A) 20 to 40 cm

■ Drive Levers(Right,Left)

WARNING

To avoid personal injury or death:

- If the swing frame has been turn 180deg, i.e. the dozer in relation to the operator's seat is "behind", then the travel direction is opposite to the drive direction of the levers (when activating the drive lever forward, the machine, in relation to the operator's seat, will move backward).

Push both drive levers simultaneously forward to drive the excavator straight forward. Releasing the drive levers stops the excavator immediately.

Pull both drive levers simultaneously backward to drive the excavator straight backward. The front of the excavator is the side where the dozer is located; the drive sprocket is in the rear of the excavator.

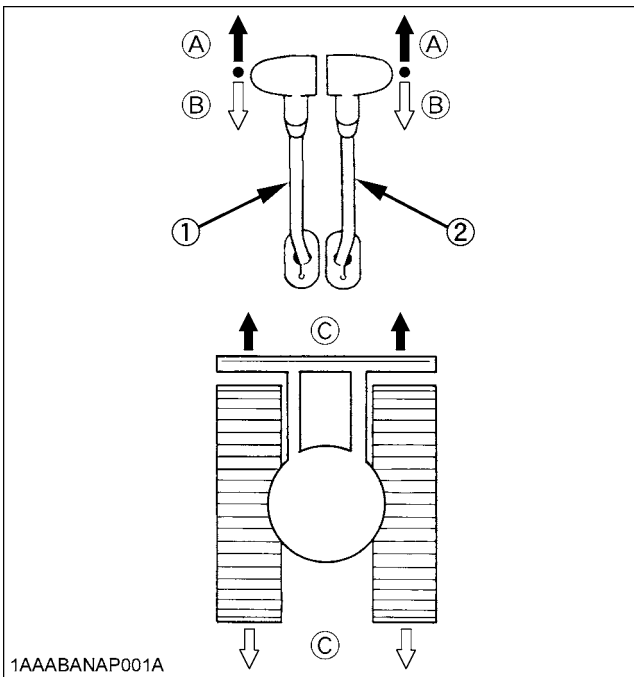

1AAABANAP001A

- (1) Drive lever (left)
- (2) Drive lever (right)
- (A) "Forward"
- (B) "Backward"
- (C) "Straight"

■ Travel Speed Switch

Travel speed will increase when this switch is pushed down.

Switching the dual travel speed:

1. Press the travel speed switch. The buzzer beeps and the travel speed changes from first speed to second. The symbol lights up.
2. Press the travel speed switch again, and the buzzer beeps and the travel speed changes from second speed to first. The symbol light goes out.

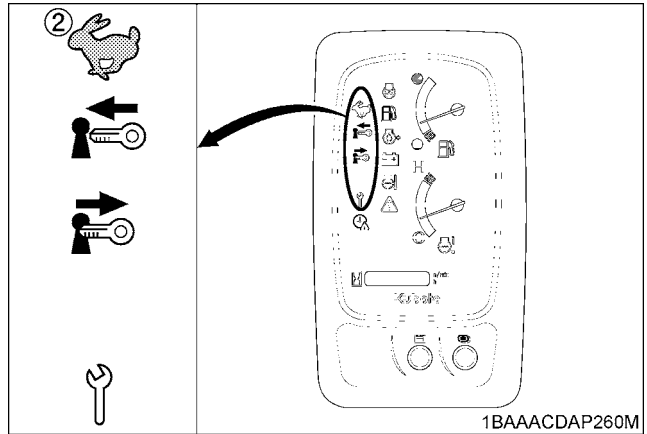

1BAAACDAP260M

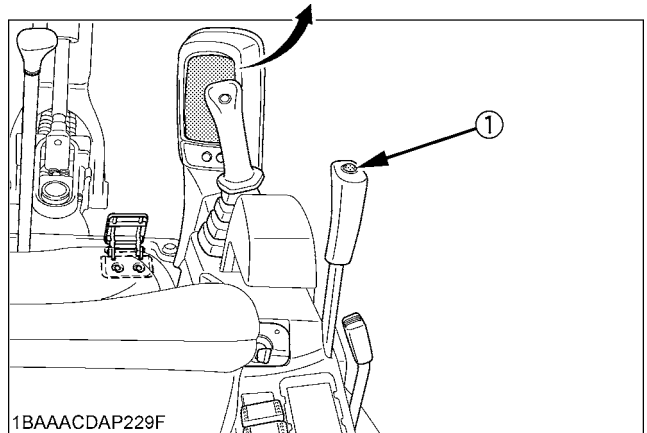

1BAAACDAP229F

- (1) Travel speed switch
- (2) Speed indicator lamp

NOTE :

- When activating the travel speed switch, it must be pushed down completely.
- Each time the travel speed switch is pressed, the travel speed is switched between first and second.

IMPORTANT :

- Do not activate the travel speed switch when there is increased drive resistance (e.g. driving on inclines or on uneven grounds).
- If the tracks are clogged with sand or gravel while working on soft ground, lift up one track with the help of the boom, arm and bucket and let the track rotate to remove the sand and gravel.

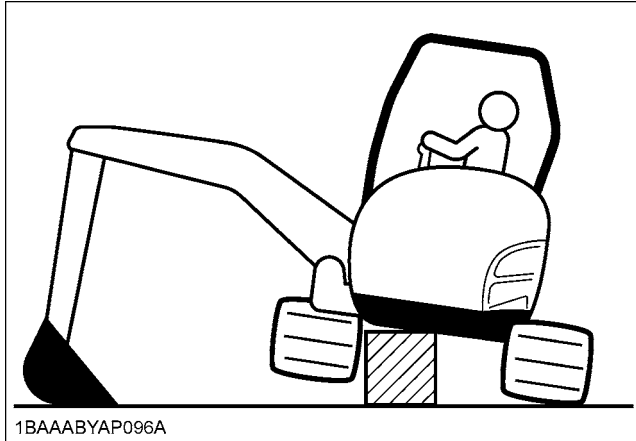

1BAAABYAP096A

(A) "Rotate to remove sand and gravel"



DANGER

To avoid serious injury or death:

- Do not work under the machine in this condition.

TURNS



CAUTION

To avoid personal injury:

- Do not change direction on steep slopes, or the excavator could tip over.
- Before changing direction, beware of people in the work area.

■ Pivot Turn

NOTE :

- Movement as illustrated is done with the dozer blade in front of the operator.

◆ Change of Direction while Travelling

1. While travelling forward, bring the left drive lever into the neutral position; the excavator will turn in the direction of the arrow of the illustration below.

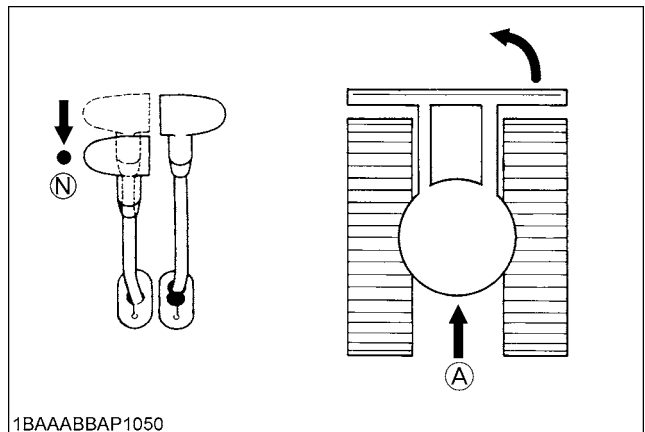

1BAAABBAP1050

(A) "Travelling forward" (N) "Neutral position"

2. While travelling backward, bring the left drive lever into the neutral position; the excavator will turn in the direction of the arrow of the illustration below.

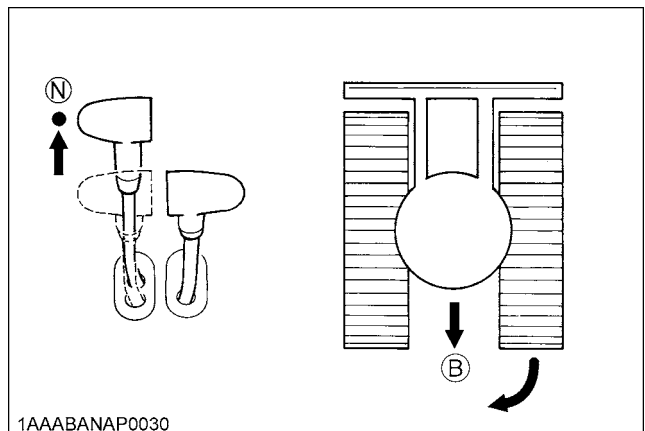

1AAABANAP0030

(B) "Travelling backward" (N) "Neutral position"

◆ **Change of Direction while Stationary**

1. Push the left drive lever forward; the excavator will turn in the direction of the arrow of the illustration below.

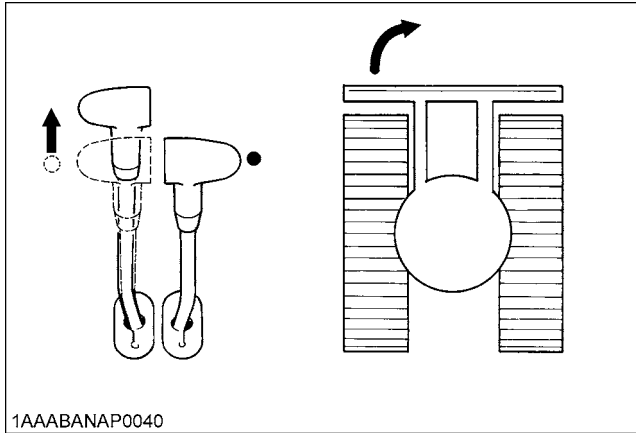

2. Pull the left drive lever backward; the excavator will turn in the direction of the arrow of the illustration below.

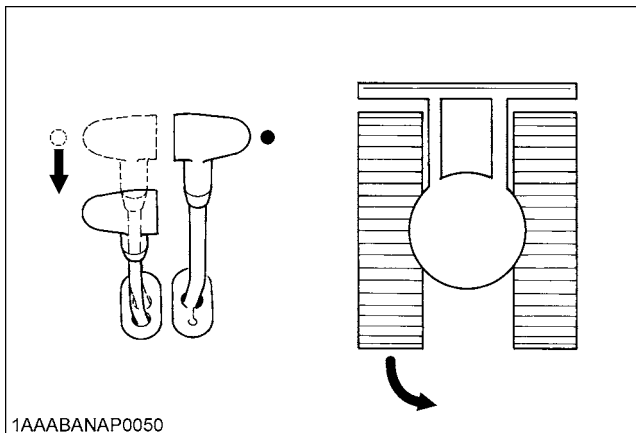

■ **Spin Turn**

When both drive levers are activated in the opposite directions, both tracks will rotate with the same speed but in opposite directions. The center of rotation is the center of the excavator.

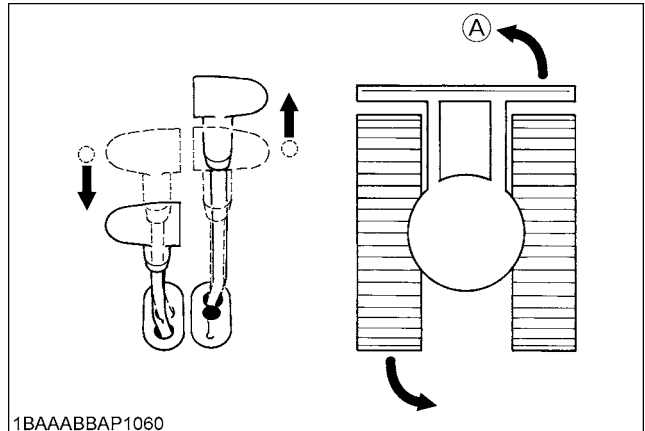

(A) "Left spin turn"

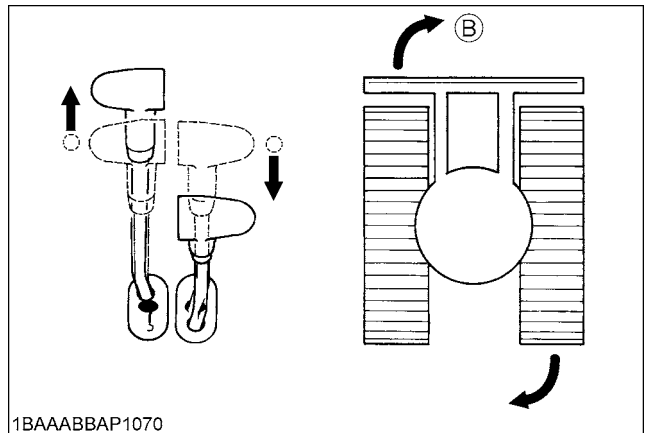

(B) "Right spin turn"

UP AND DOWNHILL DRIVING



CAUTION

To avoid personal injury:

- Before travelling up and downhill, be sure to be in standard track width (KX016-4:1240mm, KX018-4:1300mm).
- When travelling up or down a slope for long periods of time, be sure to engage the swing lock pin. Also engage the swing lock pin when standing on a slope for a long time or the excavator is being transported.

While traveling uphill, keep the lower edge of the bucket approx. 20 to 40cm (8 to 16 in.) above the ground. Although the KUBOTA excavator will not slip easily because of the tracks, it is safer to let the bucket slide over the ground while traveling downhill. Always choose slow speed for uphill and downhill traveling.

[UPHILL TRAVELING]

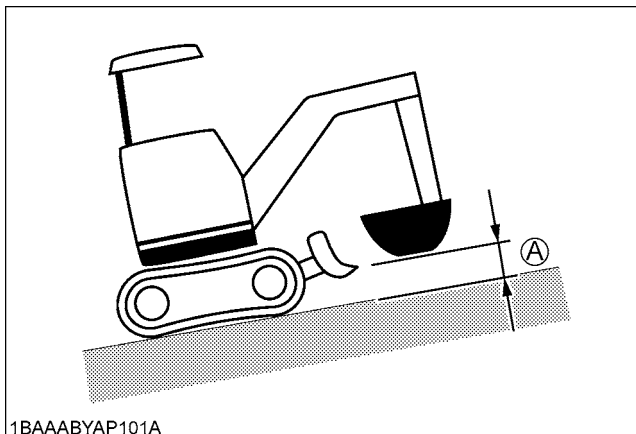

1BAAABYAP101A

(A) 20 to 40 cm (8 to 16 in.)

[DOWNHILL TRAVELING]

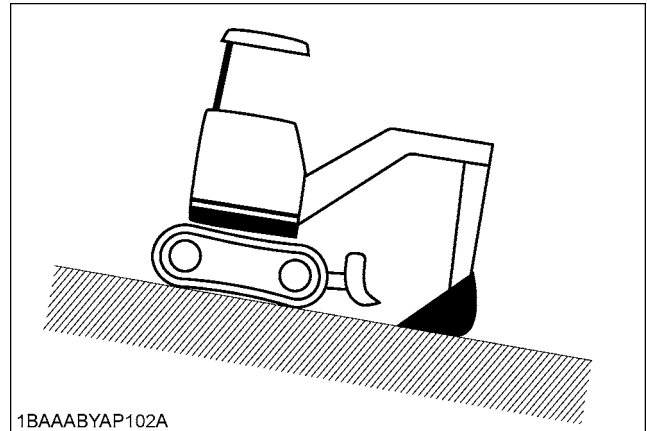

1BAAABYAP102A

TWO PATTERN SELECTION SYSTEM(TPSS)



CAUTION

To avoid personal injury:

- Study control lever pattern A and pattern B. Then choose the one which is most familiar.
- Position the pattern selector lever (located under the operator's seat) in either the lower position (Pattern A) or the upper position (Pattern B).
- Before changing the pattern, be sure to stop the engine.
- Engage the lock to prevent accidental pattern change.
- Familiarize yourself with the pattern selected by operating slowly.

■ Pattern Change

1. Open the cover and position the pattern selector lever to the desired position and engage the lock.
2. Close the cover.

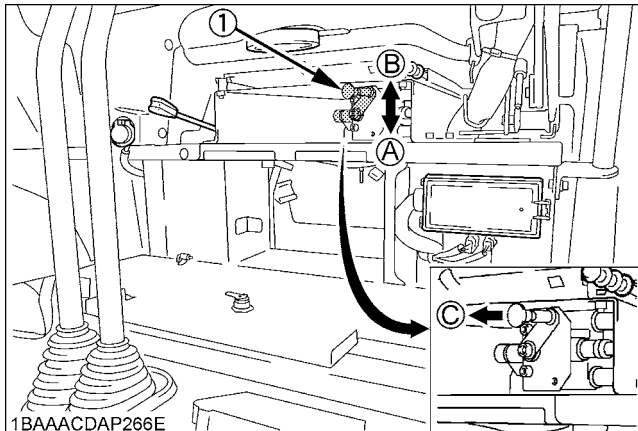

(1) Pattern selector lever
(Two Pattern Selection System:TPSS)

(A) "Pattern A"
(B) "Pattern B"
(C) Pull to unlock

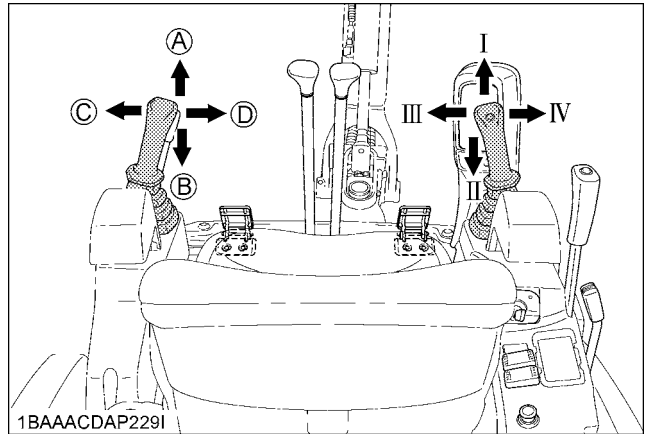

Lever Position		Pattern A	Pattern B
Attachment Control Lever (Left)	A	Boom down	Arm up
	B	Boom up	Arm crowd
	C	Swing left	Swing left
	D	Swing right	Swing right
Attachment Control Lever (Right)	I	Arm up	Boom down
	II	Arm crowd	Boom up
	III	Bucket crowd	Bucket crowd
	IV	Bucket dump	Bucket dump

OPERATION OF THE BOOM

To raise the boom, pull the attachment control lever back. The boom is equipped with a cushion cylinder which helps prevent excavated material in the bucket from falling out. At low hydraulic oil temperature, (e.g. after starting the engine in cold weather) the cushioning function will be effected for a short period of time (approx. 3 to 5 seconds). This condition results from the viscosity of the hydraulic oil and is not a sign of malfunction. The cushion cylinder will operate normally as the oil warms up. To lower the boom, push the attachment control lever forward.

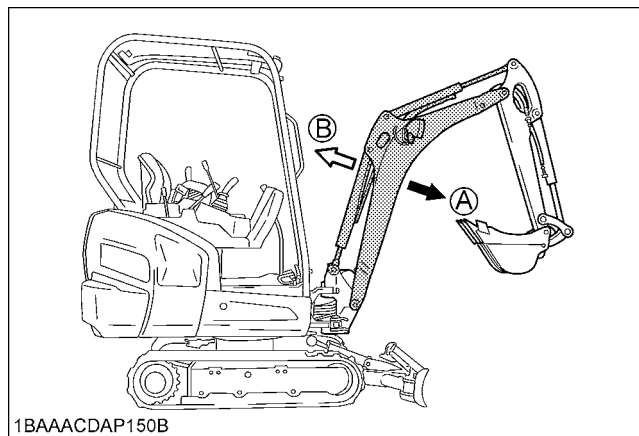
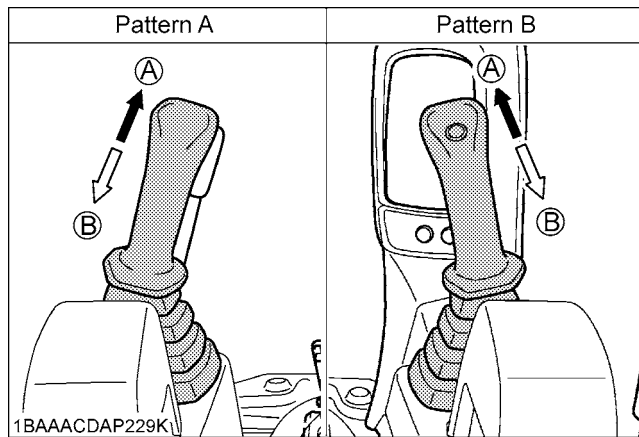

OPERATION OF THE ARM

Pull back the attachment control lever and the arm will be pulled in. To move the arm out, push the control lever towards the front.

NOTE :

- When pulling in the arm, the movement may stop for a short moment when the arm is in its vertical position. This is caused by the combined load of the arm and bucket moving the cylinder piston away from the hydraulic flow causing a delay in the cylinder action, until the flow catches up with cylinder piston. This is a characteristic of the hydraulic system and is not a sign of malfunction.

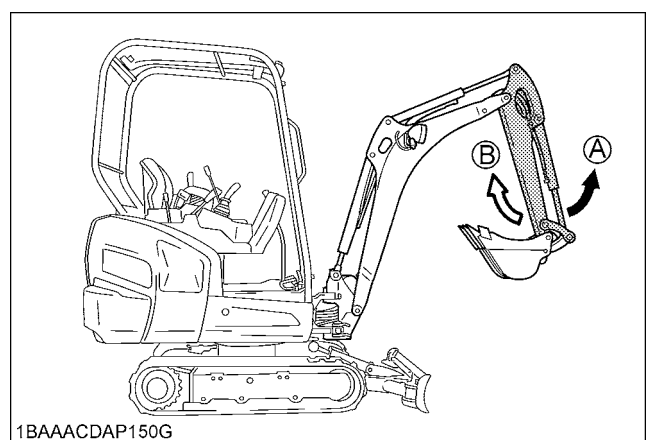
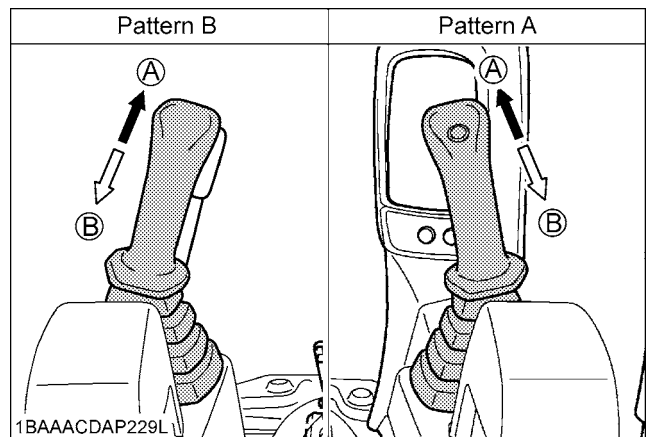

IMPORTANT :

- When lowering the boom, make sure that it does not hit the dozer and that the bucket teeth do not touch the dozer.

OPERATION OF THE BUCKET

To dig using the bucket, move the right attachment control lever from the neutral position, left. Moving the control lever right, moves the bucket outward and empties its contents.

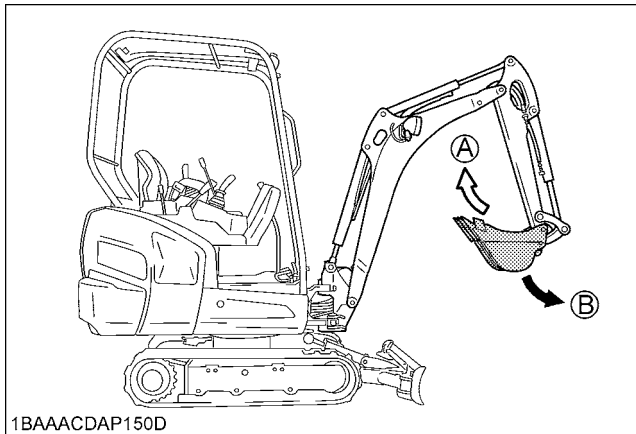
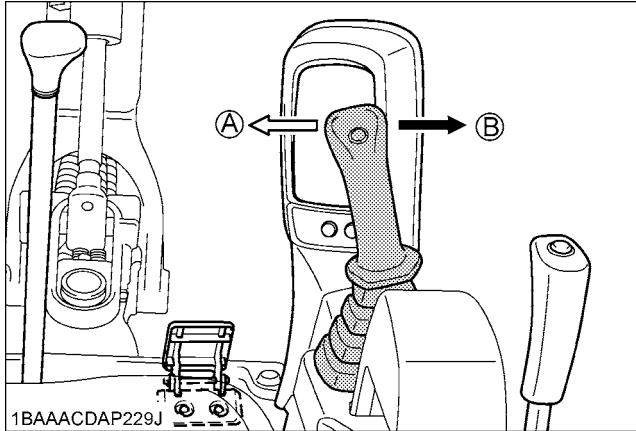

(A) "BUCKET CROWD"
(B) "BUCKET DUMP"

SWIVEL(UNIT SWING)OPERATION



CAUTION

To avoid personal injury:

- When working in groups, always let the others know what you are going to do before you do it.
- Keep away from the working area.

IMPORTANT :

- Do not operate the left attachment control lever abruptly from right to left (or vice versa). Because of the law of inertia, this causes an impact load on the swing gear and the swing motor. Additionally, the life of the excavator will be shortened.
- Unlock the swing lock pin before doing swivel operations.

1. Move the left control lever to the left and the upper structure will turn to the left.
2. Move the left control lever to the right and the upper structure will turn to the right.

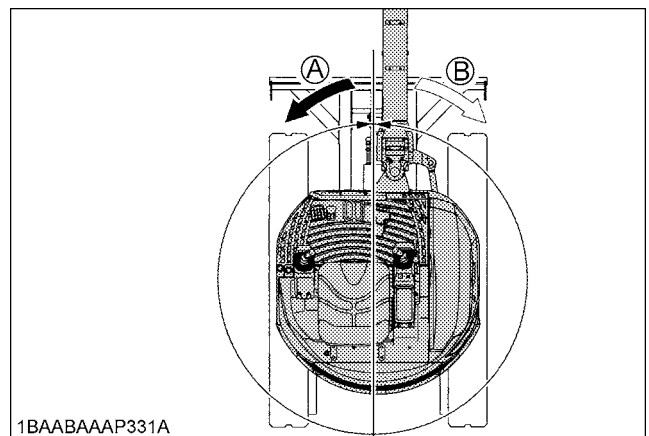
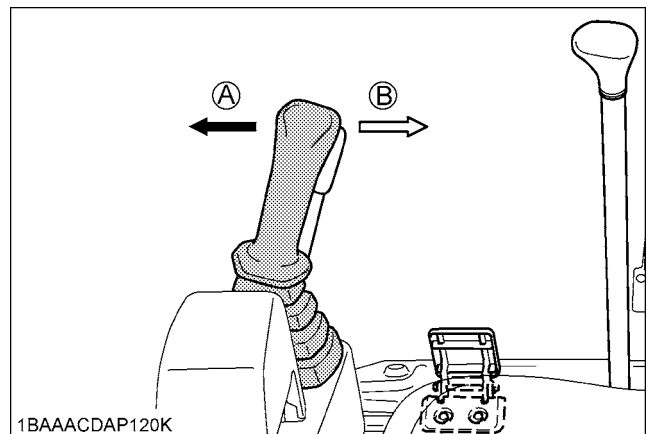

BOOM SWING OPERATION

1. Flip the pedal lock up to unlock the pedal.
2. Step on the left side of the pedal (→) to swing the boom to the left.
3. Step on the right side of the pedal (⇐) to swing the boom to the right.

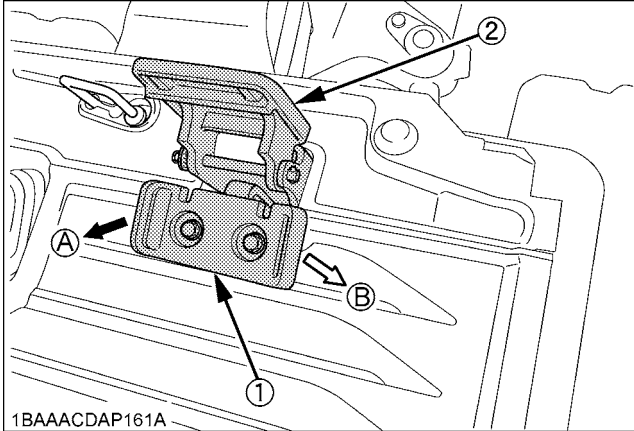

(1) Boom swing pedal
(2) Pedal lock

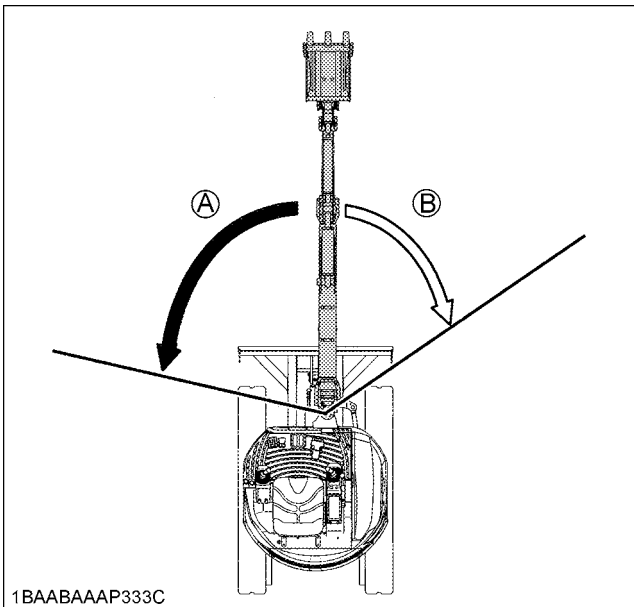

AUXILIARY PORT OPERATION



CAUTION

To avoid personal injury:

- Cover the auxiliary port pedal with the pedal lock when the pedal is not used. Be sure to cover the pedal.

This pedal is used to operate auxiliary hydraulic attachments such as breakers.

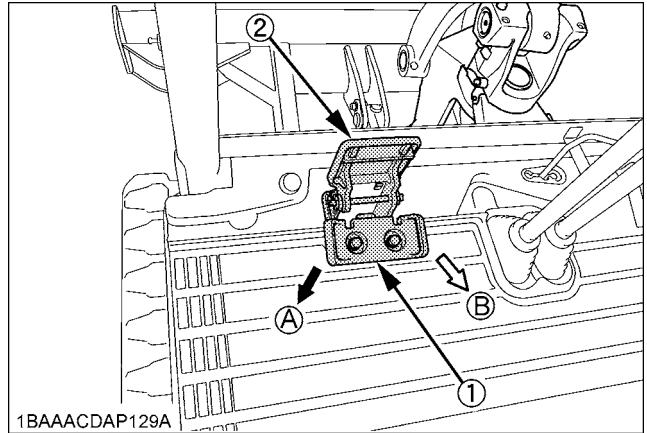

(1) AUX port pedal
(2) Pedal lock

- Push the left part of the pedal (↓), send oil to the pipe (A).
- Push the right part of the pedal (⇓), send oil to the pipe (B).

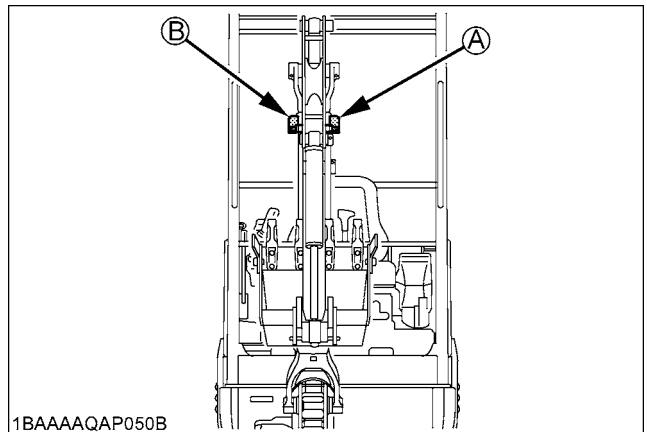

[KX016-4]

Max. Flow Volume (Theoretical L/min.)	27.0 (7.2)
Max. Pressure MPa (kgf/cm ²)	20.6 (210)

[KX018-4]

Max. Flow Volume (Theoretical L/min.)	27.7 (7.4)
Max. Pressure MPa (kgf/cm ²)	21.6 (220)

IMPORTANT :

- When the AUX port is not used for a long period, dirt particles can settle in the lower part of the service port lines.

When the plugs on the AUX port lines are removed to connect attachments, drain approx. 0.1 L of oil per side before making connections.

For breaker choices, contact your dealer.

PARKING ON A SLOPE**WARNING**

To avoid personal injury or death:

- When the excavator is parked or left unattended on a slope, be sure to put the bucket on the ground and place all control levers in neutral position, then brace the tracks with chocks.

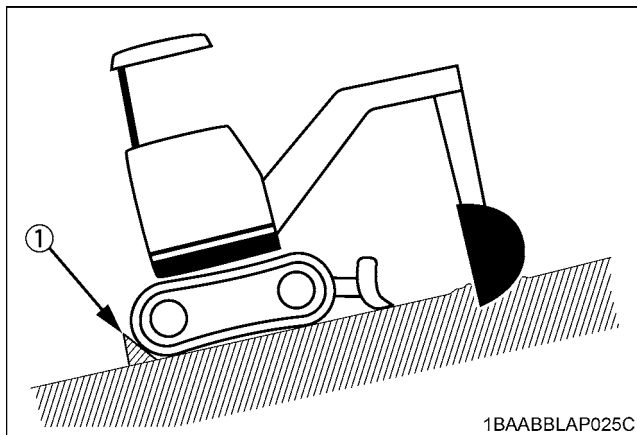

(1) Chock

IMPORTANT INFORMATION ON EXCAVATOR OPERATION

- Do not try to crush concrete or boulders using side swings with the bucket. Also avoid using side sweeps of the bucket to move earth piles.
- Under all circumstances avoid the following operations:
 - Excavation using the gravitational impact of the machine.
 - Compacting of gravel or soil using the dropping action of the bucket.
 - Excavation using the traveling power of the machine.
- Do not try to drop or shake off soil adhering to the bucket in the manner given in the points below. This can cause damage to the machine. Adhering soil can be shaken off when the bucket is being emptied by moving the bucket out to the maximum stroke of the cylinder. Should this not suffice, swing out the arm as far as possible and operate the bucket back and forth.
- Do not hit the dozer with the boom cylinder! Make sure that the boom cylinder does not hit the dozer when doing deep excavation. If necessary swing around so that the dozer is in the back of the machine.
- Pay attention when pulling in the bucket! When pulling in the bucket (for driving or transportation) avoid hitting the dozer.
- Avoid collisions! When moving the excavator, pay attention that the dozer does not collide with obstructions such as boulders etc.. Such collisions shorten the life of the dozer and the cylinder substantially.
- Support the machine correctly! When stabilizing the machine with the dozer, lower the dozer to engage the full width on the ground.
- If the water or mud level reaches higher than the top of the tracks, the swivel bearing, swivel motor gear and ring gear may be exposed to mud, water and other foreign objects. The excavator must be properly pressure washed after each use.
 - Thoroughly clean the area around the swivel bearing, swivel motor gear and ring gear to remove foreign objects.
 - Inspect the swivel motor oil sump (if equipped) for water contamination. If water is present, refer to operator's manual for lubricant replacement procedure.
 - Refer to operator's manual for proper swivel bearing, swivel motor gear and ring gear lubrication procedures.
 - Reinstall any protective covering if removed earlier.

TRANSPORTING THE EXCAVATOR ON A VEHICLE



DANGER

To avoid personal injury or death:

- No directional changes should be made when the excavator is on the ramp. Should a change of direction be necessary, drive off the ramp completely and make the turn.
- When driving forward or backward onto the vehicle, or when swinging the upper body, make sure that neither the CAB or the gates of the vehicle will be damaged.

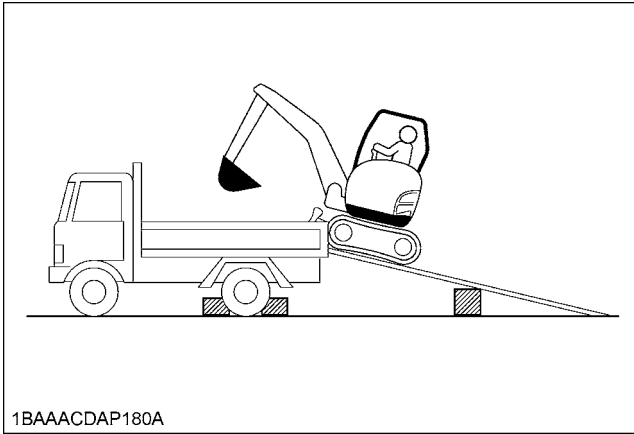

- When the excavator reaches the point between the ramps and the bed, halt and then move very slowly until the excavator reaches the horizontal position.
- Move the excavator onto the vehicle only with the arm completely pulled in. Otherwise the CAB of the vehicle could be damaged when swinging around the upper body.
- Do not jack up the machine using its boom to load or unload the excavator from the vehicle. Doing this is dangerous.
- Make sure the ramp are of sufficient capacity and securely connected to the vehicle to safety support the machine throughout the loading / unloading operation.

Transporting on a truck



WARNING

To avoid personal injury or death:

- After loading the machine on the truck, lower the bucket and dozer onto the truck bed. Lock the swing frame with the swing lock pin.

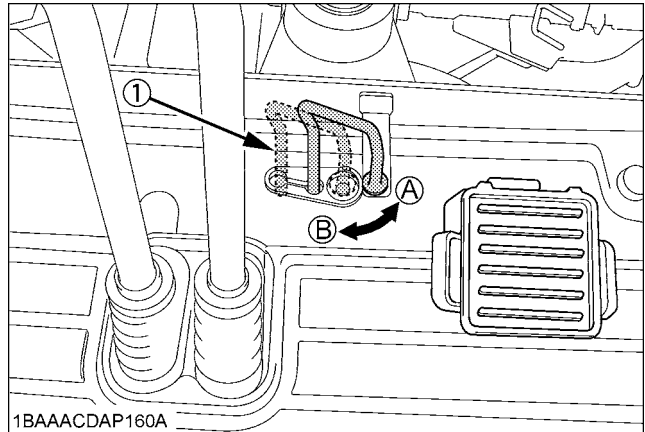

(1) Swing lock pin

(A) "Unlock"

(B) "Lock"

Prepare a platform to load or unload the excavator.

Take following steps when using ramps.

1. Apply the parking brakes of the vehicle, and block the drive wheels from both sides.

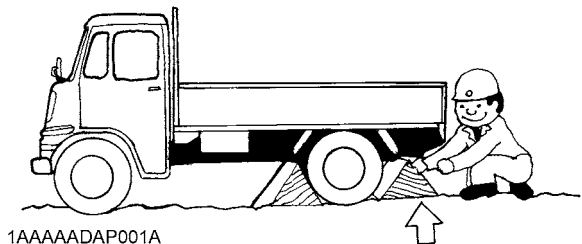

2. Use mounting brackets to secure the ramp properly. Connect the ramps directly to the bed.

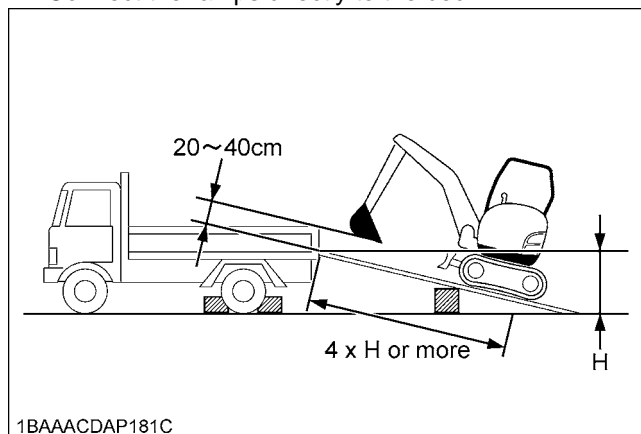

(A) 4 x H or more

3. For additional safety, use blocks or supports under the ramps and the bed.

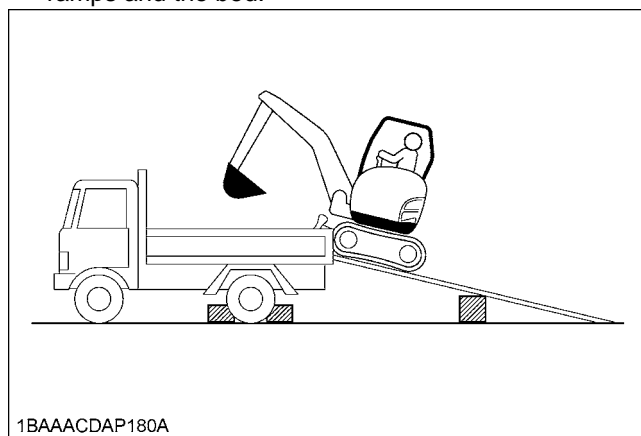

4. Align the ramps and the tracks and then drive the excavator slowly up the ramps. After ensuring that the tracks are completely on the bed, swing the upper body around to the back of the vehicle.

5. Block the tracks and cable down the excavator with suitable chains and approved method (check appropriate state regulation).

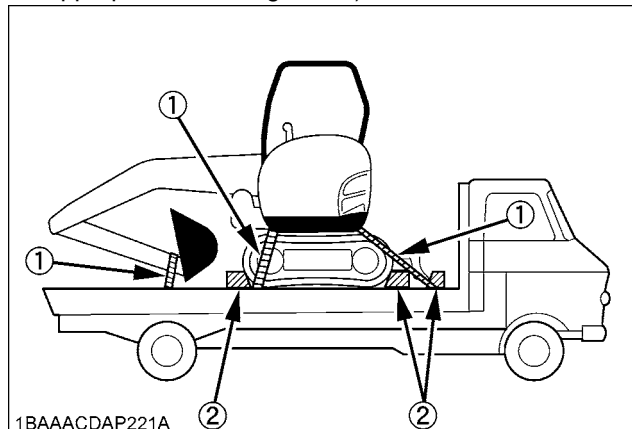

- (1) Chain
(2) Block

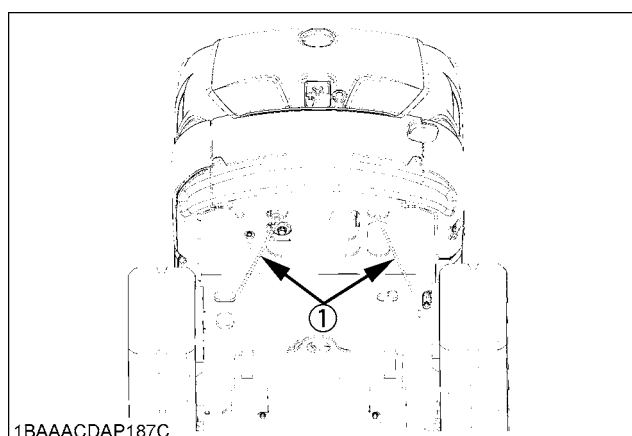

- (1) Chain

Rated capacity at the tie down points	1680 N (171 kg)
---------------------------------------	--------------------

6. Before unloading, raise the dozer and bucket from the bed.

LIFTING OF THE EXCAVATOR



DANGER

To avoid serious injury or death:

- The correct instructions for safe handling are described here. Read these instructions carefully before moving the machine. Make sure that the operating personnel read the operator's manual carefully.

■ Basics when Lifting with Cables or Straps

1. The lifting and crane operation is to be undertaken according to the safe operation guidelines described.
2. The equipment used for lifting mentioned in these instructions are only given as reference, the standards concerning strength, control and other details are based on the respective applicable guidelines.

■ Safety Aspects when Lifting with Cables or Straps

Abide by following steps when lifting:

1. Do not lift loads that exceed the maximum load capacity of the crane.
2. Choose correct equipment suitable to the weight, size and form of the load.
3. First assess the center of gravity of the load, position the hook directly over the load and lift the load so that the center of gravity of the load is as low as possible.
4. The steel cables or straps must be fixed in the middle of the hook.
5. The load must be lifted vertically from the ground.
6. Do not enter the working area under suspended loads and do not move the load over people. The load must only be moved in an area where the balance can be easily maintained.

■ Lifting Procedure for the Excavator



WARNING

To avoid personal injury or death:

- Do not use the hooks on the roof of canopy for lifting the excavator.

◆ General guidelines for lifting

1. Lifting position. (see the following illustration.)
 - (1) Pull in the boom completely toward the canopy.
 - (2) Pull in the arm completely.
 - (3) Pull in the bucket completely.
 - (4) Adjust the swing angle to the center. (to bring the boom in a position parallel to the machine frame)
 - (5) Swing frame so that dozer blade is to the rear and frame is parallel with tracks.
 - (6) Raise the dozer blade fully.
2. Attaching the steel cables or straps.
 - (1) Always hook the excavator at three points. (one on the boom and left and right of the dozer)
 - (2) Always use a shackle on each lifting hole when attaching the cables or straps.
 - (3) Using protective material at all places where the cables or straps contact the machine.
 - (4) Keep the angle between the front and rear cables or straps within 60° (1.05 rad.).

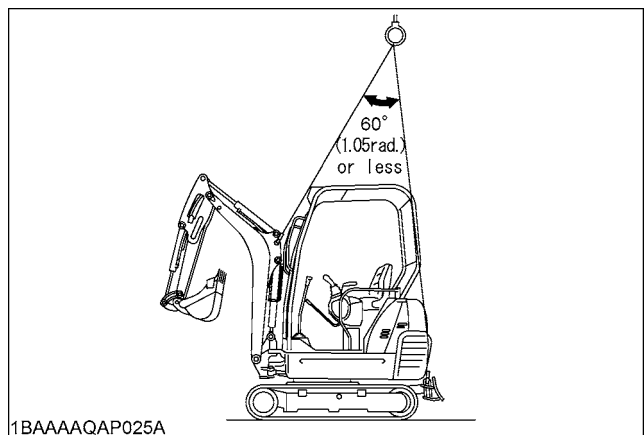

3. Tackle

The weights of the excavators and the recommended tackle for lifting these loads are mentioned in the following table. Choose components having enough strength.

Excavator Weight* [KX016-4]	Canopy : 1490 kg
Excavator Weight* [KX018-4]	Canopy : 1620 kg
Load / Cable	6400 N (652 kgf)
Minimum Cable Diameter (Safety factor=6)	10 mm or more

*Excavator Weight: With long arm.
Steel cable: 6 x 24

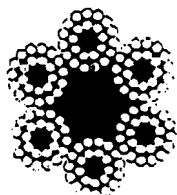

1AAABANAP034A

4. Lifting

- (1) Lift slowly and safely.
- (2) Do not enter the excavator area when lifting.

Maximum strength

for example : (JIS G 35 25) - "6 x24"

Diameter	zinc-plated	not zinc-plated
10 mm (3/8)	45.8 kN (4670 kgf)	49.3 kN (5027 kgf)
12.5 mm (1/2)	71.5 kN (7290 kgf)	77 kN (7851 kgf)
14 mm (9/16)	89.7 kN (9146 kgf)	96.6 kN (9850 kgf)
16 mm (5/8)	117 kN (11930 kgf)	126 kN (12848 kgf)
18 mm (45/64)	148 kN (15091 kgf)	160 kN (16315 kgf)

1. Boom side

Hook in the steel cable with a shackle into the lifting hole.

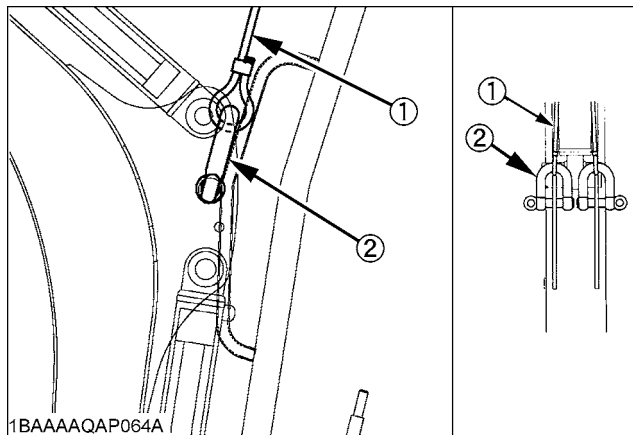

1BAAAAQAP064A

- (1) Steel cable
- (2) Shackle

2. Dozer side

Hook in the steel cable with a shackle into the lifting hole around the canopy.

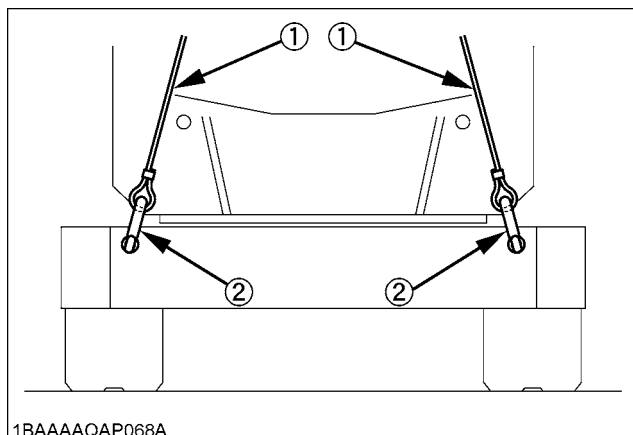

1BAAAAQAP068A

- (1) Steel cable
- (2) Shackle

MAINTENANCE



CAUTION

To avoid personal injury:

- **Before doing maintenance work on the machine, place the machine on a firm, flat and level surface, lower the attachments and dozer blade on the ground, release the cylinder pressure by actuating the levers, stop the engine, lock all control levers, remove the key and then block the tracks with the blocks.**

Whether the machine is properly lubricated and maintained directly determines the trouble frequency and service life of the machine. Periodically check and maintain your machine, and you will find in the long run that the jobs can be finished earlier and more economically.

Shown in the Service Interval Chart below are the hours indicated on the hourmeter, practically, it will be convenient to schedule the time of inspection and maintenance according to the calendar (day, week, month) on the basis of the chart. If the machine is used in harder-than-usual working conditions, it must be checked and maintained at shorter intervals.

MAINTENANCE INTERVALS

No.	Check points		Measures	Hour meter indicator										Interval	Ref. page			
				50	100	150	200	250	300	350	400	450						
1	Coolant		check	Daily check											40			
			change												every 2 years	54		
2	Fuel		check	Daily check											40			
3	Engine oil		check	Daily check											41			
			change	●					○						every 250 hrs	48		
4	Hydraulic oil		check	Daily check											42			
			change												every 1000 hrs	52	*1	
5	Lubrication points		-	Daily check											43			
6	Radiator and oil cooler		check	Daily check											44			
7	Engine and electrical wiring		check	Daily check											44			
8	Fuel tank, Water separator		drain	○	○	○	○	○	○	○	○	○	○	○	every 50 hrs	45, 45		
9	Battery condition		check	○	○	○	○	○	○	○	○	○	○	every 50 hrs	46			
10	Greasing swing bearing teeth		-	○	○	○	○	○	○	○	○	○	○	every 50 hrs	47			
11	Fan belt tension		check	Daily check											44			
			adjust				○					○		every 200 hrs	49			
12	Radiator hoses and clamps		check				○					○		every 200 hrs	47			
			replace												every 2 years	54		
13	Air filter element	Outer element	clean				○					○		every 200 hrs	47	*2	@	
		Inner element	replace											every 1000 hrs	53	*2		
			replace												every 1000 hrs	53		*2
14	Greasing swing ball bearing		-				○					○		every 200 hrs	48			
15	Engine oil filter		replace	●						○				every 250 hrs	49			
16	Fuel filter element		replace											every 500 hrs	50		@	
17	Drive unit oil		change	●										every 500 hrs	50			
18	Hydraulic return filter element		replace					●						every 500 hrs	51			
19	Hydraulic suction filter element		replace											every 1000 hrs	52			
20	Fuel injection nozzle injection pressure		check											every 1500 hrs	53	*4	@	
21	Front idler and track roller oil		change											every 2000 hrs	53			
22	Alternator and starter motor		check											every 2000 hrs	53			
23	Injection pump		check											every 3000 hrs	53	*4	@	
24	Radiator system		rinse											every 2 years	54			
25	Fuel line and Intake air line		check				○					○		every 200 hrs	48		@	
			replace											every 2 years	55	*3		

* 500 thru 1000 continued to the following table.

No.	Check points		Measures	Hour meter indicator							Interval	Ref. page				
				500	550	600	650	700	750	800					1000	
1	Coolant		check	Daily check								40				
			change									every 2 years	54			
2	Fuel		check	Daily check								40				
3	Engine oil		check	Daily check								41				
			change		○					○		every 250 hrs	48			
4	Hydraulic oil		check	Daily check								42				
			change								○	every 1000 hrs	52	*1		
5	Lubrication points		-	Daily check								43				
6	Radiator and oil cooler		check	Daily check								44				
7	Engine and electrical wiring		check	Daily check								44				
8	Fuel tank, Water separator		drain	○	○	○	○	○	○	○	○	○	every 50 hrs	45, 45		
9	Battery condition		check	○	○	○	○	○	○	○	○	○	every 50 hrs	46		
10	Greasing swing bearing teeth		-	○	○	○	○	○	○	○	○	○	every 50 hrs	47		
11	Fan belt tension		check	Daily check								44				
			adjust			○				○	○	every 200 hrs	49			
12	Radiator hoses and clamps		check			○				○	○	every 200 hrs	47			
			replace										every 2 years	54		
13	Air filter element	Outer element	clean			○					○	○	every 200 hrs	47	*2	@
		Inner element	replace									○	every 1000 hrs	53	*2	
			replace										○	every 1000 hrs	53	
14	Greasing swing ball bearing		-			○				○	○	every 200 hrs	48			
15	Engine oil filter		replace		○						○		every 250 hrs	49		
16	Fuel filter element		replace	○							○	every 500 hrs	50		@	
17	Drive unit oil		change	○							○	every 500 hrs	50			
18	Hydraulic return filter element		replace							○		every 500 hrs	51			
19	Hydraulic suction filter element		replace								○	every 1000 hrs	52			
20	Fuel injection nozzle injection pressure		check									every 1500 hrs	53	*4	@	
21	Front idler and track roller oil		change									every 2000 hrs	53			
22	Alternator and starter motor		check									every 2000 hrs	53			
23	Injection pump		check									every 3000 hrs	53	*4	@	
24	Radiator system		rinse									every 2 years	54			
25	Fuel line and Intake air line		check			○					○	○	every 200 hrs	48		@
			replace											every 2 years	55	*3

IMPORTANT :

● First operation

*1 When using a hydraulic hammer, change hydraulic oil and return filter according to the table on "Hydraulic Oil Change (Including Exchange of the Suction Filter in the Hydraulic Tank) under "EVERY 1000 SERVICE HOURS" in the chapter "REGULAR CHECKS AND MAINTENANCE WORK".

*2 Clean and replace the air filter more frequently if used under dusty conditions. When the filter is very dirty from dusty conditions, replace the filter.

*3 Replace only if necessary.

*4 Consult your local KUBOTA dealer for this service.

● The items listed above (@ marked) are registered as emission related critical parts by KUBOTA in the U.S.EPA non-road emission regulation. As the engine owner, you are responsible for the performance of the required maintenance on the engine according to the above instruction. Please see the warranty Statement in detail.

OPENING AND CLOSING OF PARTS

■ Opening and Closing of the Fuel Tank Cap

1. Open the tank cap cover, insert the starter key and turn counterclockwise. Then turn the tank cap counterclockwise to open.

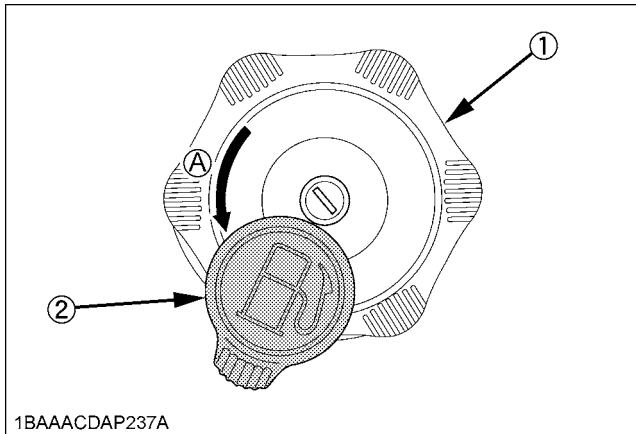

- (1) Fuel tank cap (A) Open
 (2) Tank cap cover

2. To close the tank cap, turn clockwise and turn clockwise the starter key. Then close the tank cap cover.

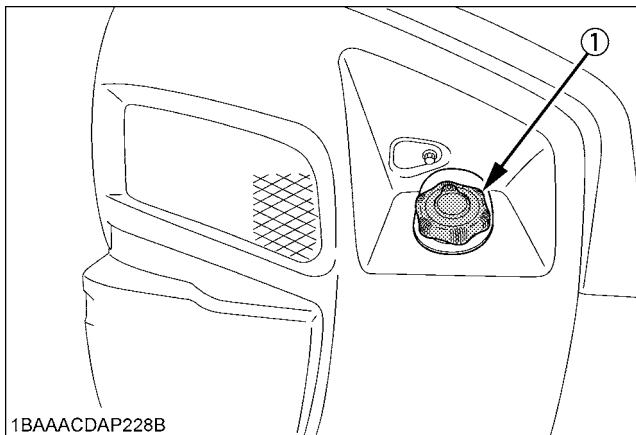

- (1) Fuel tank cap

◆ How to use the funnel

This machine is provided with a funnel that is a standard accessory.

When refueling the machine, remove the cap and put the funnel into the filler port. Turn the funnel clockwise until it clicks with its opening directed upward.

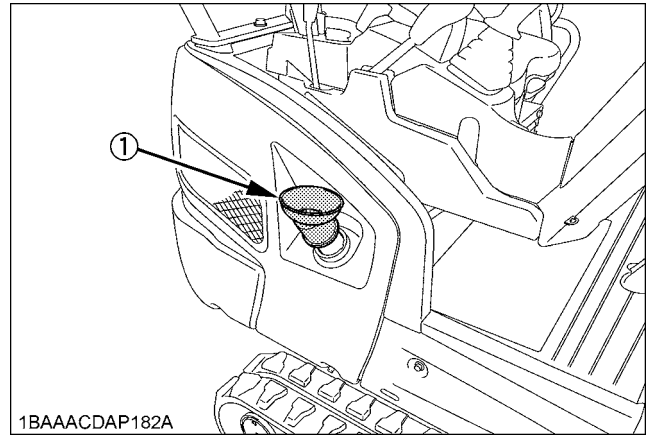

- (1) Funnel

NOTE :

- Keep the funnel, inserting it in the sack, at the location as shown below.

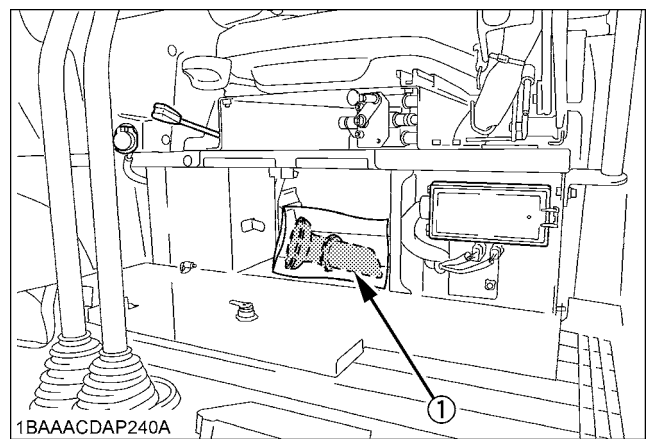

- (1) Funnel

■ Opening/Closing of the Engine Hood

CAUTION

To avoid personal injury:

- Do not open the engine hood with the engine running unless in an emergency.
- Do not touch the exhaust muffler or the exhaust pipe; serious burns can occur.

Insert the key into the key slot and turn it clockwise to open the hood. To close it, lower the hood and hold it down tightly. Turn the key counterclockwise to lock the hood.

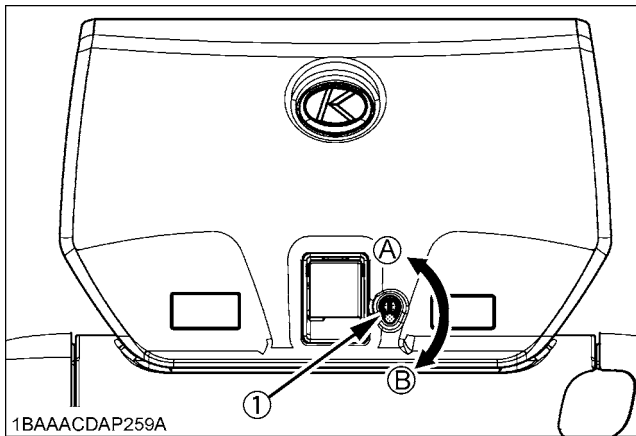

1BAAACDAP259A

(1) Key slot

(A) "LOCK"
(B) "UNLOCK"

■ Where to store the Grease Gun

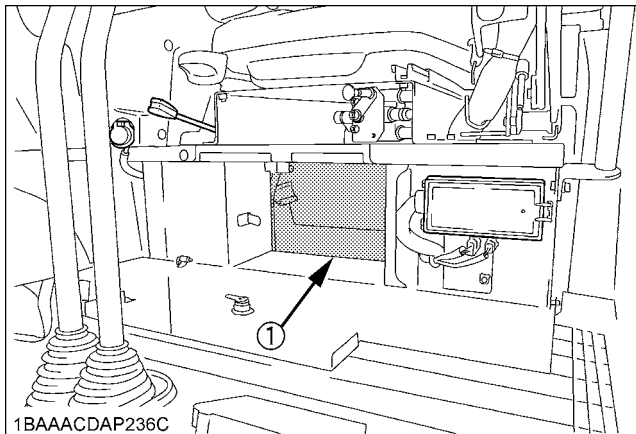

1BAAACDAP236C

(1) Grease gun storage

■ Where to keep Operator's Manual

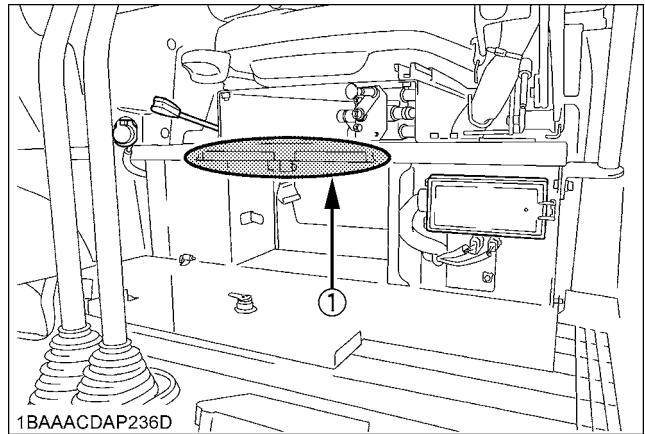

1BAAACDAP236D

(1) Operator's manual storage

■ Cup Holder

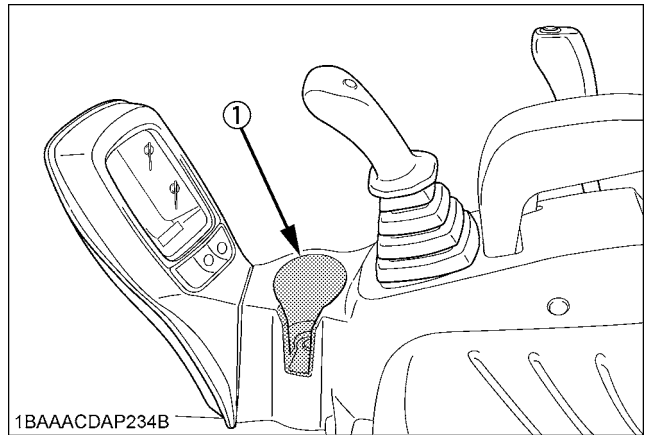

1BAAACDAP234B

(1) Cup holder

DAILY CHECKS

For your own safety and to assure the long life of your machine, a careful check should be made before each operation.

■Checking Coolant Level



CAUTION

To avoid personal injury:

- Move the excavator to even ground.
- Make sure that the engine is turned off.
- Do not open the radiator cap right after the engine has been stopped; Serious burns can occur from contact with escaping hot coolant fluid.
- Check the coolant level in the reserve tank only after the engine has cooled down.
- Remove the radiator cap only if absolutely necessary.

1. Check to see that the coolant level is between the "FULL" and "LOW" marks of the reserve tank.
2. When the coolant level drops due to evaporation, add water only up to the full level.
In case of leakage, add anti-freeze and water in the specified mixing ratio up to the full level.
(See "Changing Radiator Coolant " in every 2 years maintenance.)

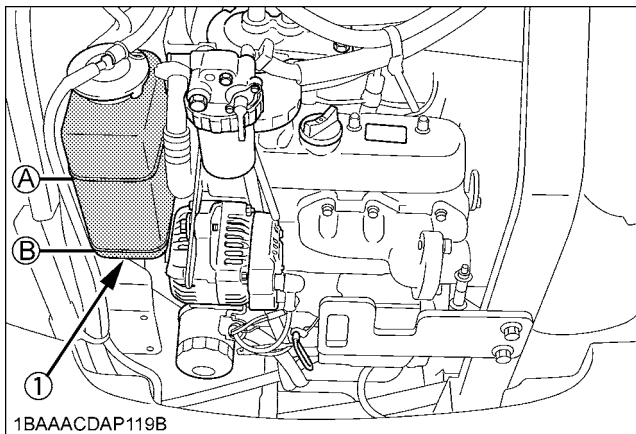

1BAAACDAP119B

(1) Reserve tank

(A) "FULL"
(B) "LOW"

IMPORTANT :

- Do not fill the reserve tank over the "FULL" marking.
- Do not fill with dirty or salty water.

■Checking Fuel Level



CAUTION

To avoid personal injury:

- Stop the engine and remove the key before fuelling.
- Do not smoke while fuelling.

IMPORTANT :

- By temperatures over -5°C, use No.2-D diesel fuel, when temperatures are under -5°C, use No.1-D diesel fuel.
- Make sure that the fuel tank will not run empty. Air will enter the fuel system, and must be purged before restarting the engine.
- See "PURGING FUEL SYSTEM" in "OTHER ADJUSTMENTS AND REPLACEMENTS" section.
- To prevent condensation (water) accumulations in the fuel tank, fill the fuel tank full before parking overnight.

1. Check the fuel level by the fuel level indicator.

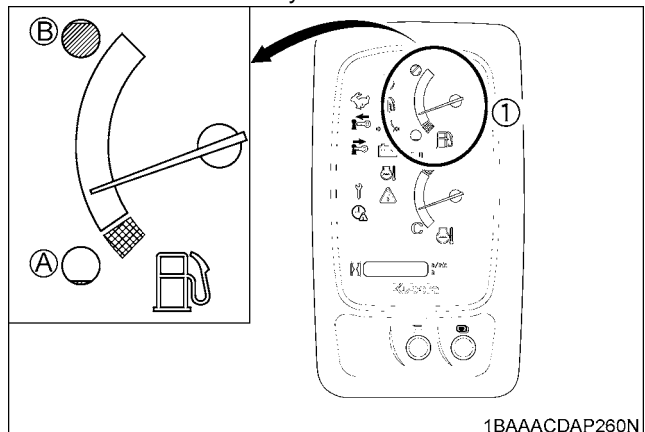

1BAAACDAP260N

(1) Fuel gauge

(A) "EMPTY"
(B) "FULL"

2. Open the tank cap with the starter key, and add fuel.

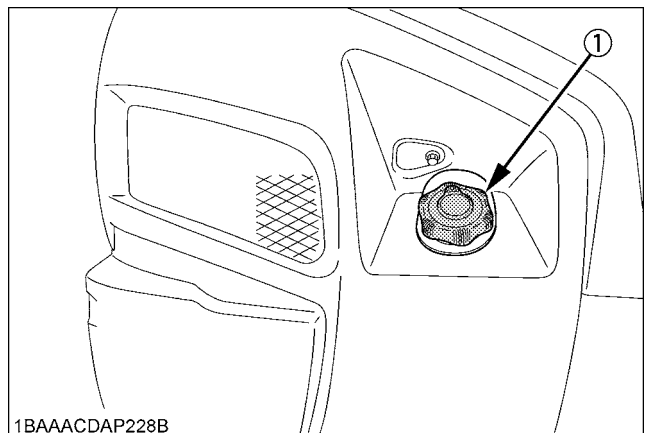

1BAAACDAP228B

(1) Fuel tank cap

◆ **Fuel level audible indication switch (when refueling)**

1. With the starter key at the "OFF" position, press the the user setting switch (switch 2) or the display selector switch (switch 3), and the fuel level can be checked with buzzer sound.
2. Start refueling the machine. The buzzer beeping intervals vary according to how much fuel is poured into the tank. As the tank fills, the buzzer sounds almost continuously.
3. While refueling the machine, listen to the buzzer to know how much the fuel tank is filled.
4. If fuel is poured too slowly, the buzzer sound gets interrupted. When it is poured again as usual, the buzzer restarts sounding.
5. To stop refueling halfway (before filling up), press the fuel level audible indication switch or leave as it is (not refueling) for a while. The buzzer stops sounding.

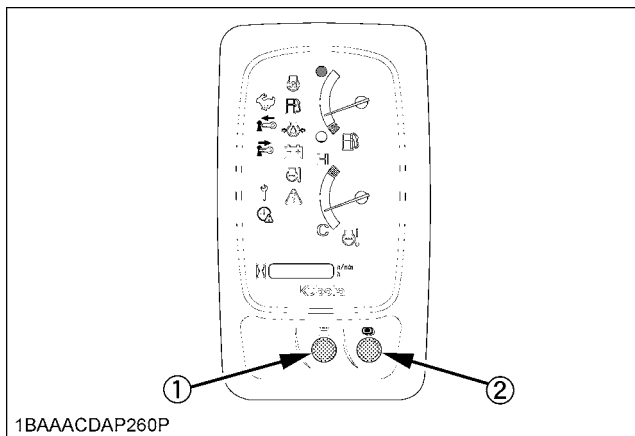

- (1) User setting switch (switch 2)
- (2) Display selector switch (switch 3)

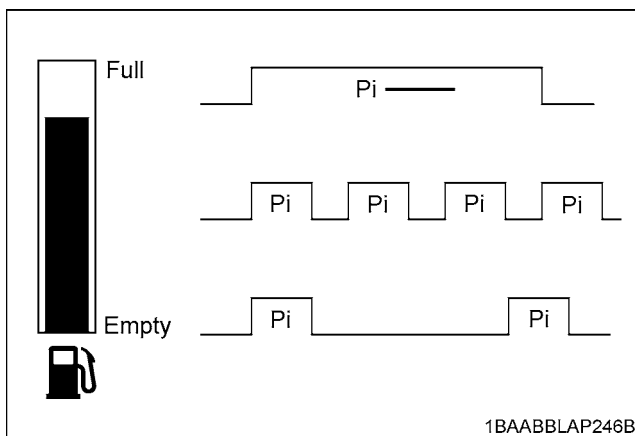

■ **Checking Engine Oil Level**



To avoid personal injury:

- Stop the engine and remove the key before checking the oil level.

IMPORTANT :

- Use engine oil with the correct viscosity. (according to the outside temperature)
- After stopping the engine and remove the key, wait five minutes, then check oil level. (Excavator must be on level ground.)

Insert the engine oil dipstick fully into the respective port opening, remove again and check the oil level; if necessary fill with oil. The machine must be on level ground when checking the oil level.

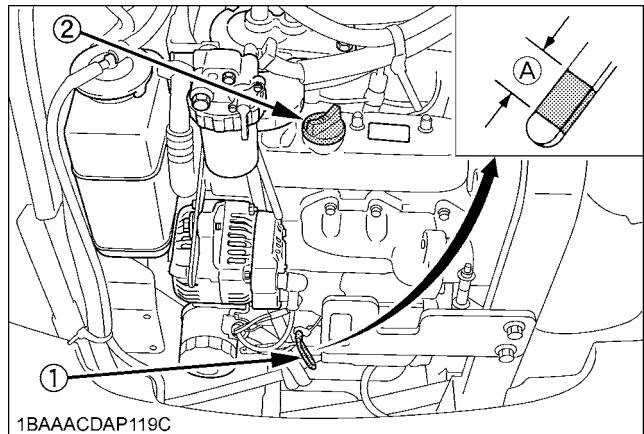

- (1) Engine oil dipstick
- (2) Filling port

(A) Required oil level range

■Checking Hydraulic Oil Level



CAUTION

To avoid personal injury:

- Stop the engine and remove the key before checking the oil level.

IMPORTANT :

- Before filling oil, wipe away all sand and dust from around the oil port. Make sure to use an identical type of hydraulic fluid.
 - The excavator has been filled with hydraulic fluid before delivery. See "RECOMMENDED OILS". (Do not mix different oils.)
1. Park the excavator on a firm, flat and level surface. Lower the attachments and dozer blade to the ground and stop the engine.

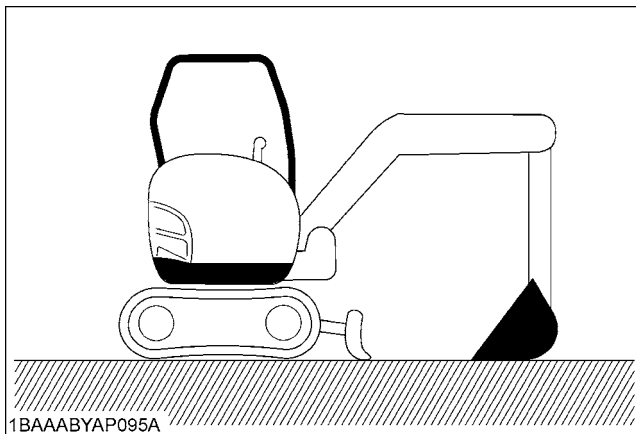

2. Check the oil level as to whether it lies on the center of the gauge at normal temperature (10 to 30°C).
3. Enough oil is present if the oil level lies near the center of the gauge.

4. Should the oil level be too low, fill oil through the oil port before starting the engine. This step is important for the protection of the hydraulic system.

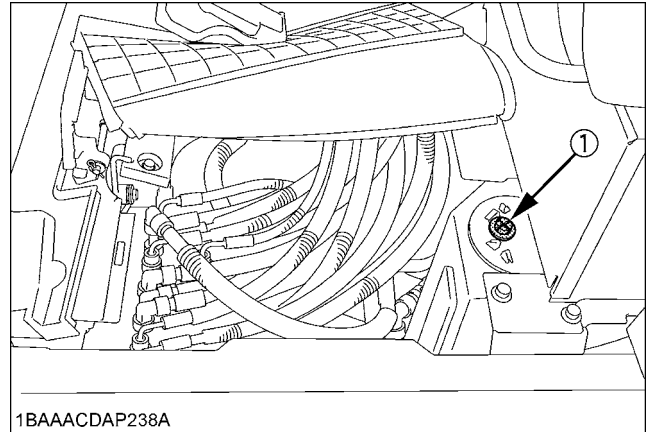

(1) Tank cap

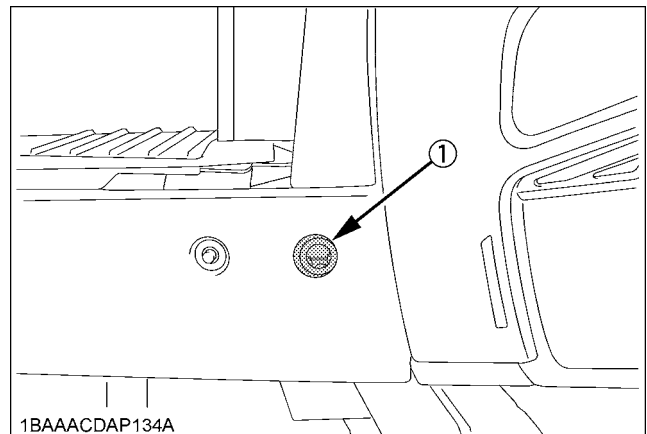

(1) Gauge

■ Lubrication Points

CAUTION

To avoid personal injury:

- First lower all attachments to the ground then stop the engine and remove the key.
- While greasing, take caution not to step on the bucket teeth.
- When doing excavation work in water, generously grease the following points. After ending work, grease again.

Grease the marked grease nipples shown by arrows in the illustration below.

- | | | |
|-----|--|----------|
| 1. | Boom bottom linkage..... | 1 place |
| 2. | Arm bottom linkage..... | 1 place |
| 3. | Bucket link pin..... | 3 places |
| 4. | Boom cylinder boss..... | 2 places |
| 5. | Arm cylinder boss..... | 2 places |
| 6. | Bucket cylinder boss..... | 1 place |
| 7. | Fixing pin between arm and bucket..... | 1 place |
| 8. | Swing cylinder boss..... | 1 place |
| 9. | Swing cylinder bottom..... | 1 place |
| 10. | Swing pin..... | 2 places |
| 11. | Dozer cylinder boss (or pin)..... | 2 places |
| 12. | Dozer linkage pin..... | 2 places |

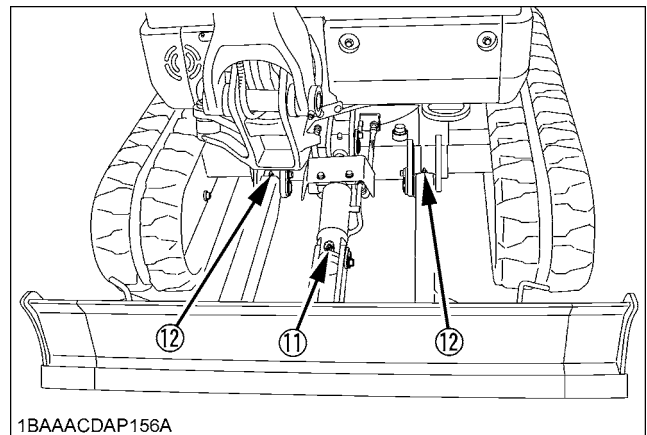
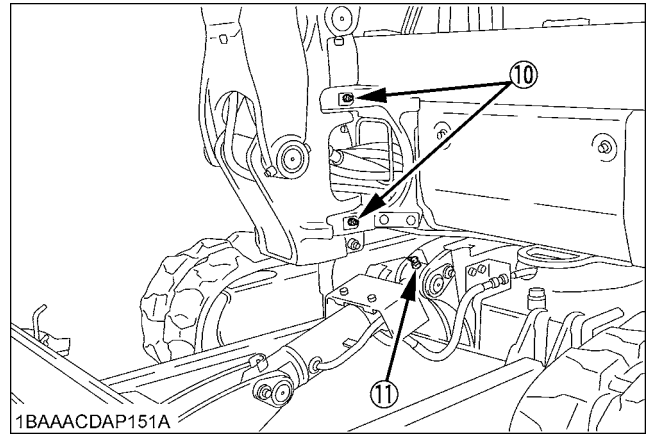
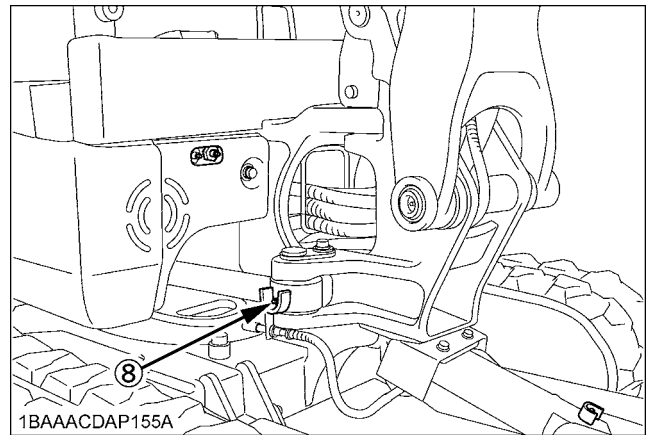
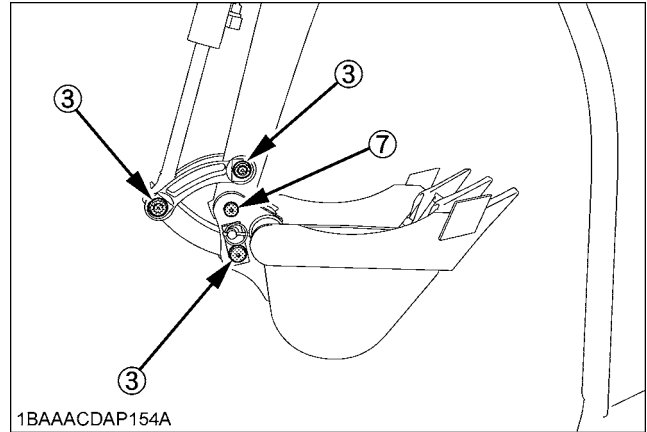
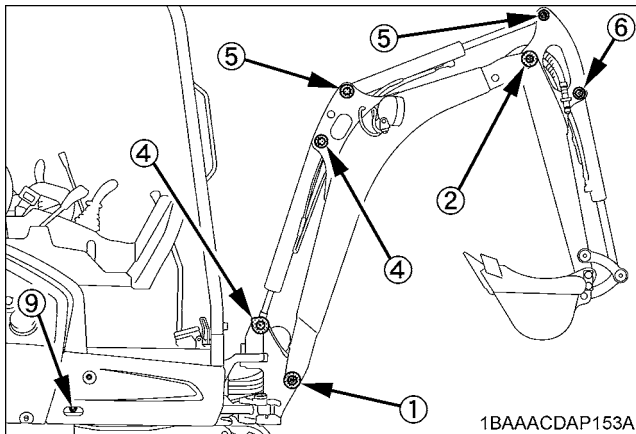

■ Check Fan Belt



CAUTION

To avoid personal injury:

- Stop the engine and remove the key before checking the fan belt.
- Check the fan belt for cracks and proper tension. (See "Checking Fan Belt Tension" in "REGULAR CHECKS AND MAINTENANCE WORK" section.)

■ Checking Radiator and Oil Cooler



CAUTION

To avoid personal injury:

- Always stop the engine and remove the key before checking the radiator.
- Wear eye protection when cleaning with compressed air.

1. Check if the fins and ribs are clogged.
If so clean with compressed air or steam.
2. Check the rubber hoses for damage and replace if cracked or old. Check if the hose clamps are tight enough.

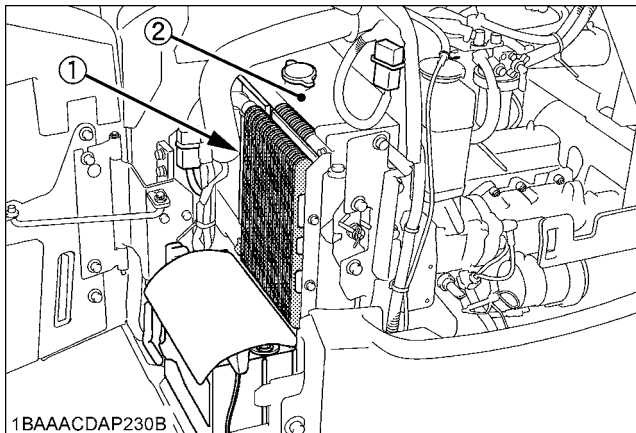

- (1) Oil cooler
(2) Radiator

IMPORTANT :

- Radiator and oil cooler fins and ribs must be clean in order not to overheat the engine and allow free flow of air through the cooling elements.
- Pressure of compressed air must be under 205 kPa (2.1 kgf.cm²).

■ Checking and Cleaning Engine and Electrical Wiring



CAUTION

To avoid personal injury:

- Always stop the engine and remove the key before cleaning the wiring, cables and engine.

Before starting, check whether flammable substances have gathered on the battery, the cables and wiring, the muffler or on the engine. Remove thoroughly. Check the electrical circuitry for disconnections, shorts or loose terminals.

■ Washing Whole Machine

IMPORTANT :

- Do not wash the excavator with the engine running. Water could enter the air filter and damage the engine. Make sure that the air filter is kept dry.
- Remove the mud before washing the machine.

REGULAR CHECKS AND MAINTENANCE WORK



CAUTION

To avoid personal injury:

- Before doing maintenance work on the machine, place the machine on a firm, flat and level surface, lower the attachments and dozer blade on the ground, release the cylinder pressure by actuating the levers, stop the engine, lock all control levers, remove the key and then block the tracks with the blocks.

EVERY 50 SERVICE HOURS

■ Draining Fuel Tank



CAUTION

To avoid personal injury:

- Before draining the fuel tank, be sure to stop the engine and remove the key.
- Do not smoke during inspection.

1. Turn the drain cock to "CLOSED" position and remove the drain plug.
2. Turn the drain cock to "OPEN" position and drain water.

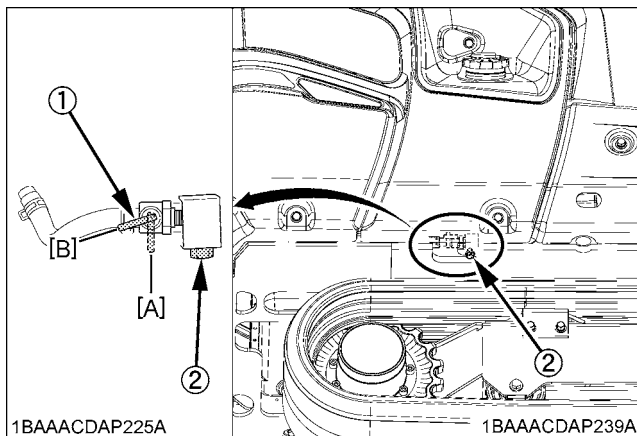

- (1) Drain cock
(2) Drain plug

- (A) "CLOSED"
(B) "OPEN"

■ Checking Water Separator

1. Open the hood.
2. When the separated water is being drained, the red float moves upwards. When the float reaches the indication line, close the cock so that no fuel can run out. Now loosen the ring nut, and remove the cup and empty completely.
3. Clean carefully not to damage the filter element.
4. Finally, do not forget to open the cock and close the hood.

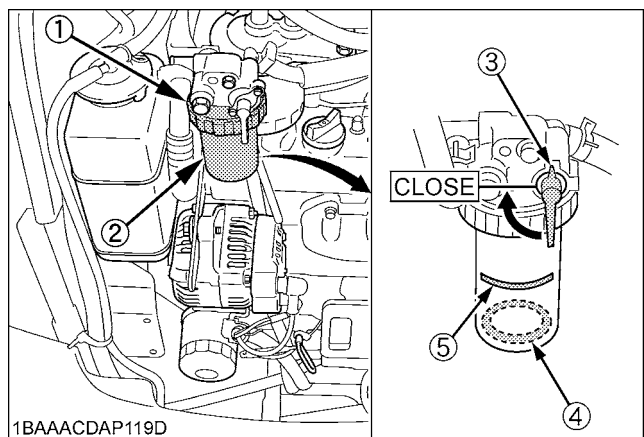

- (1) Ring nut
(2) Cup
(3) Cock

- (4) Float
(5) Indication line

■ Battery



DANGER

To avoid the possibility of a battery explosion:
For refillable type battery, follow the instructions below.

- Do not use or charge the refillable type battery if the fluid level is below the LOWER (lower limit level) mark. Otherwise, the battery component parts may prematurely deteriorate, which may shorten the battery's service life or cause an explosion. Check the fluid level regularly and add distilled water as required so that the fluid level is between the UPPER and LOWER levels.



CAUTION

To avoid personal injury:

- Never remove the vent caps while the engine is running.
- Keep electrolyte away from eyes, hands and clothes. If you are splattered with it, wash it away completely with water immediately and get medical attention.
- Wear eye protection and rubber gloves when working around the battery.
- Before inspection or dismantling the battery, be sure to turn off the engine and turn the starter switch to the "OFF" position.
- When removing the battery, always disconnect the negative ground cable first. When installing a battery, always connect the ground cable last. This prevents a possible explosion caused by sparks.
- Always wear eye protection when working with the battery.
- Never smoke or have open flame when working near the battery.

■ Battery Charging



CAUTION

To avoid personal injury:

- When the battery is being activated, hydrogen and oxygen gases in the battery are extremely explosive. Keep open sparks and flames away from the battery at all times, especially when charging the battery.
- When charging battery, make sure battery vent plugs are secured.
- When disconnecting the cable from the battery, start with the negative terminal first. When connecting the cable to the battery, start with the positive terminal first.
- Do not check battery charge by placing a metal object across the terminals. Use a voltmeter or hydrometer.

1. Make sure each electrolyte level is to the bottom of vent wells. If necessary, add distilled water in a well-ventilated area.
2. The water in the electrolyte evaporates during recharging. Liquid shortage damages the battery. Excess liquid spillage damages the excavator.
3. To slow charge the battery, connect the battery positive terminal to the charge positive terminal and the negative to the negative, then recharge in the standard fashion.
4. A boost charge is only for emergencies. It will partially charge the battery at a high rate and in a short time. When using a boost-charged battery, it is necessary to recharge the battery as early as possible. Failure to do this will shorten the battery's service life.
5. When the specific gravity of electrolyte falls between 1.27 and 1.29 charge has completed.
6. When exchanging an old battery for a new one, use a battery of equal specification.

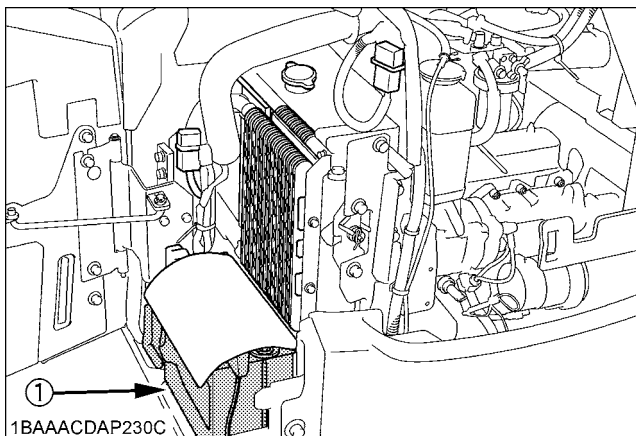

(1) Battery

■ Greasing Swing Bearing Teeth

1. Pump grease with grease gun through the grease nipple (at the right end side).
2. Grease at each 90° (1.58 rad.) position of the swing frame.
3. Fill with approx. 50g of grease (approx. 20 to 30 pumps with the grease gun at each position).

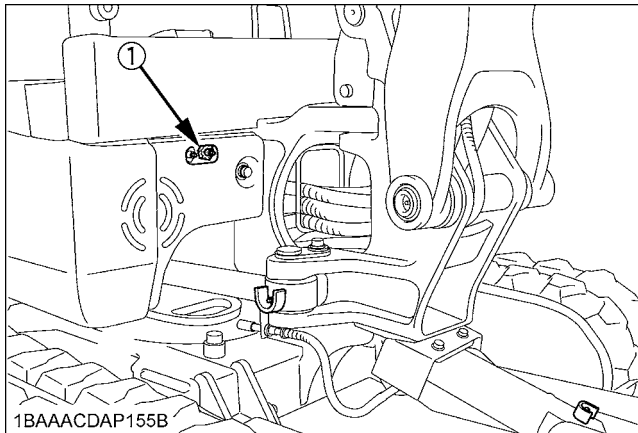

(1) Grease nipple

EVERY 200 SERVICE HOURS

Do all 50-hour servicing at the same time.

■ Checking Radiator Hoses and Clamps



CAUTION

To avoid personal injury:

- Wait long enough for the radiator coolant to cool down.

Check the coolant hoses for proper connection. This check should be carried out every 200 hours or every 6 months, whichever comes first.

1. Should the hose clamps become loose or water leaks, tighten the hose clamps properly.
2. Should the radiator hoses become swollen, aged or cracked, they must be replaced and the hose clamps tightened again properly. (See "Replacing of Radiator Hoses" in "BIENNIAL SERVICING" in "REGULAR CHECKS AND MAINTENANCE WORK" section.)

■ Inspection and Cleaning Air Filter Element

Open the engine cover and remove the dust cover. Take out only outer element, clean the element, case interior and reassemble. During reassembly, take care to install the dust cover with facing the TOP mark upward. Do not remove the inner element (safety element).

IMPORTANT :

- Should the machine be used in extremely dusty areas, the air filter element must be inspected and cleaned more frequently than in the specified maintenance periods.
- The air filter has a dry element, keep free from oil.
- Do not run the engine without the air filter.

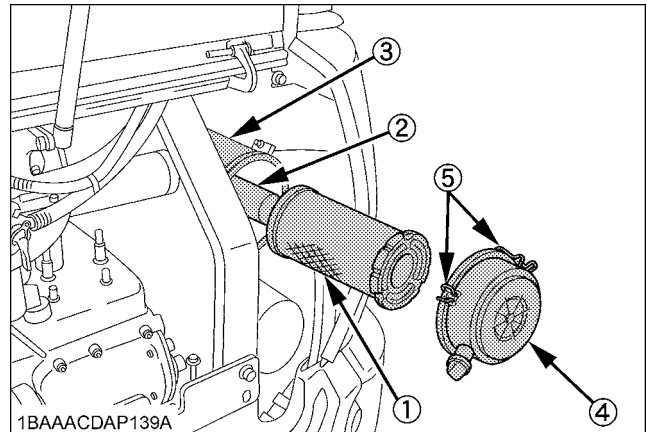

- (1) Outer element
- (2) Inner element (safety element)
- (3) Case
- (4) Dust cover
- (5) Clamps

■ Air Filter Maintenance



CAUTION

To avoid personal injury:

- Wear eye protection.

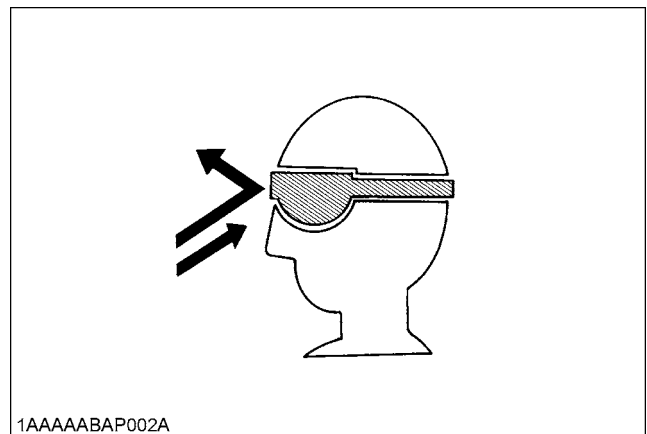

The quickest and safest method of maintenance is the exchange of the paper cartridge. Furthermore there are different methods of cleaning the cartridge.

◆ Cleaning with compressed air

Pressure of compressed air must be under 205 kPa (2.1 kgf/cm²), and the cartridge should be blown clean from the inside to the outside until the dust deposits are noticeably reduced.

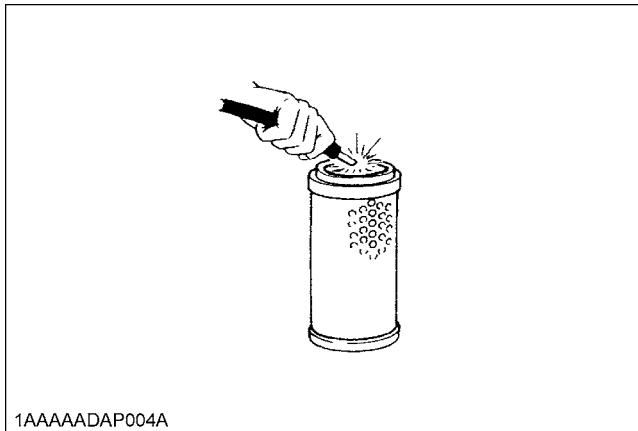

IMPORTANT :

- If the air suction is still inadequate, or the color of the exhaust gases is abnormal even after the cleaning, the air filter cartridge must be replaced.

■ Greasing Swing Ball Bearing

1. Fill with grease through the respective grease nipple.
2. Grease at each 90° (1.58 rad.) position of the swing frame.

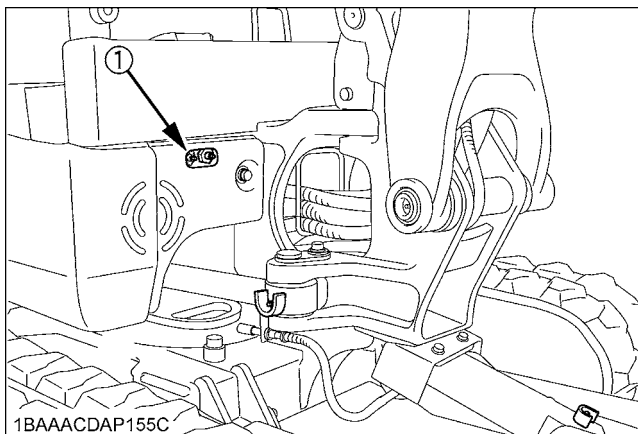

(1) Grease nipple

■ Checking Fuel Line and Intake Air Line

1. Check to see that all lines and hose clamps are tightened and not damaged.
2. If hoses and clamps are found worn or damaged, replace or repair them at once.

EVERY 250 SERVICE HOURS

Do all 50 hour servicing at the same time.

■ Changing Engine Oil (First Engine Oil Change after 50 Service Hours)



CAUTION

To avoid personal injury:

- First stop the engine then remove the key and wait long enough for the oil to cool down.

1. Remove the drain plug on the underside of the engine and drain all oil.
2. Re-tighten the drain plug.

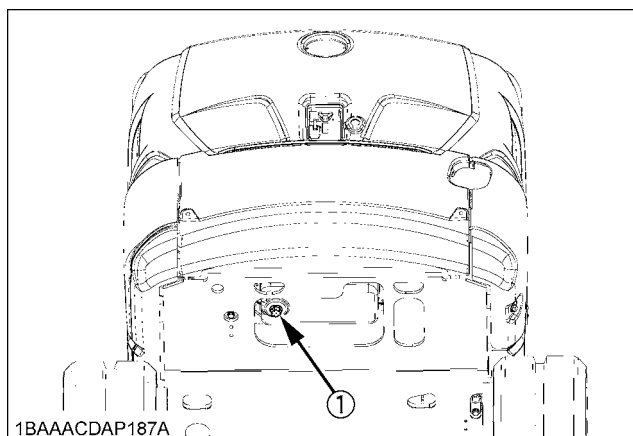

(1) Drain plug

3. Fill through the filling port up the specified level.

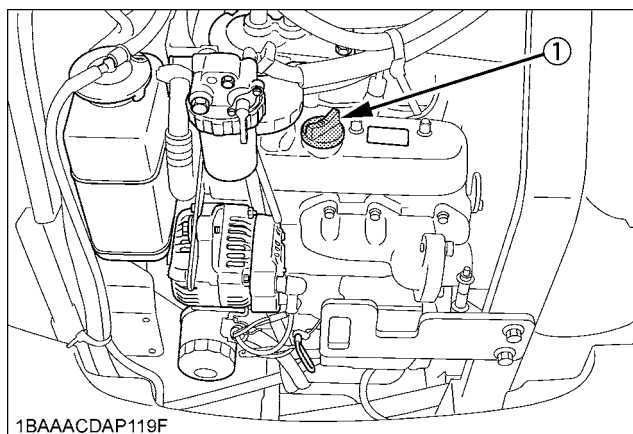

(1) Oil filling port

- Let the engine idle for approx. 5 min. Check the engine oil level. To check the engine oil level, insert the engine oil dipstick completely into the respective port opening and pull out again. If the oil level lies between both markings, oil level is sufficient.

IMPORTANT :

- Regardless of the service hours, an engine oil change is due every six months.

Replacing Engine Oil Filter(First Engine Oil Filter Change after 50 Service Hours)

- Replace the oil filter cartridge at the same time as doing the engine oil change.
- Remove the cartridge with the supplied filter wrench.

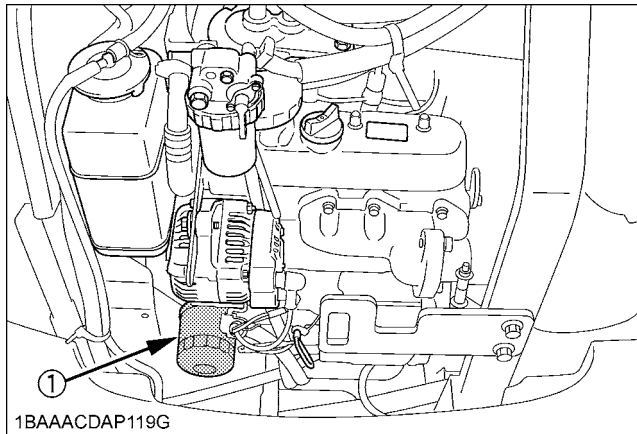

(1) Oil filter

- Oil the O-ring of the new oil filter cartridge lightly. Then tighten the oil filter cartridge by hand.
- Fill engine oil to the specified level between the 2 marks on the gauge.
- Let the engine run for approx. 5 min. and make sure that the engine oil pressure warning lamp does not light up. Then stop the engine and remove the key.
- The engine oil level is reduced by the amount of the filter capacity after the engine is started. It is necessary to add oil.

IMPORTANT :

- Always check the oil level after having exchanged the filter.

Engine oil volumes (with engine oil filter)	3.6L
--	------

Checking the Fan Belt Tension

◆ Check and adjustment of the fan belt tension



CAUTION

To avoid personal injury:

- First stop the engine and remove the key.
- After servicing, make sure to replace the belt cover in its original position.

- Press the fan belt down in the middle, with a force of approx. 98 N (10 kgf, 22 lbf). The belt tension is correct if it deflects about 8 mm (0.3 in.). If otherwise, loosen bolt (1) shift the alternator (2) in the direction shown by the arrow.
- Replace the fan belt if worn out, cracked or torn.

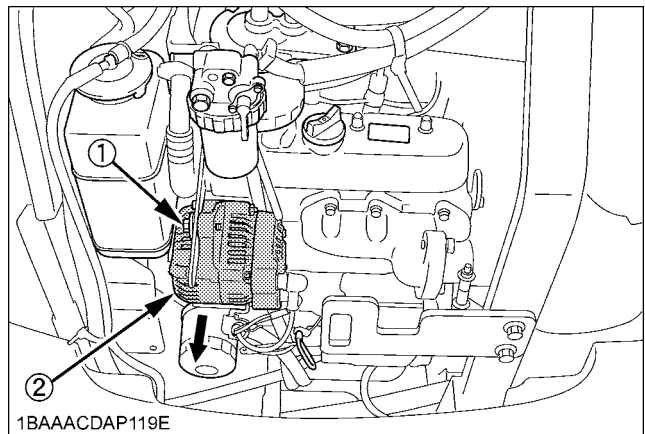

(1) Bolt
(2) Alternator

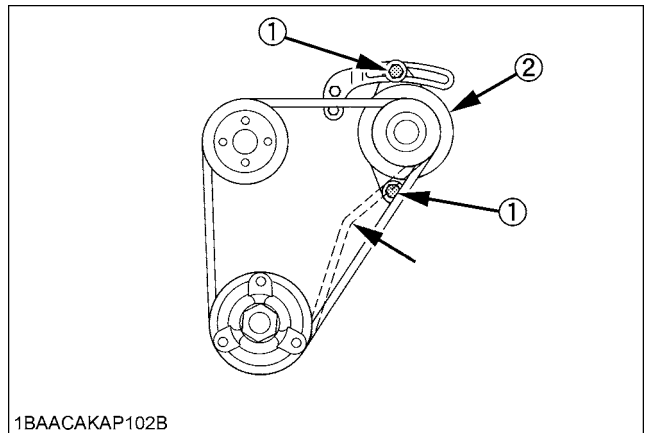

(1) Bolt
(2) Alternator

IMPORTANT :

- If the engine is run with a loose fan belt, the belt could slip and cause overheating of the engine or insufficient battery charging. Check fan belt tension regularly.

- Should the fan belt break or jump off, the battery charge lamp will light up. Stop the engine and remove the key immediately.

EVERY 500 SERVICE HOURS

Do all 50 hour servicing at the same time.

■ Drive unit Oil Change (First Oil Change of the 50 hours)



CAUTION

To avoid personal injury:

- Lower all attachments to the ground, stop the engine and remove the key before undertaking the oil change.

1. Rotate the track so that the drain plug of the drive unit is in the bottom position.
2. Remove the drain plug to let the oil run out. Screw in and tighten the drain plug again and fill with gear oil through the oil filling port.
3. Fill oil until it overflows out of the oil filling port.

Oil change

- first oil change after 50 hrs
- then every 500 hrs
- or at least once a year

4. Use prescribed gear oil SAE 90.

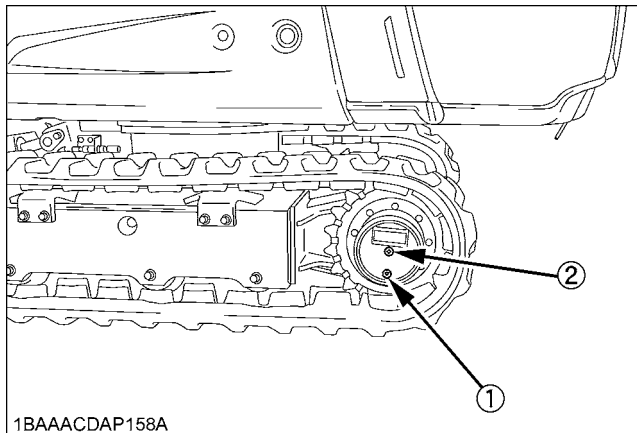

- (1) Drain plug
(2) Oil filling port

Gear oil volume	approx. 0.33 L
-----------------	----------------

■ Replacing Fuel Filter Element



CAUTION

To avoid personal injury:

- Keep fire away.

1. Remove the filter with the supplied filter wrench.
2. Apply a light film of fuel to the seal of the new filter and turn in tightly by hand.
3. Open the cock of the fuel filter again.

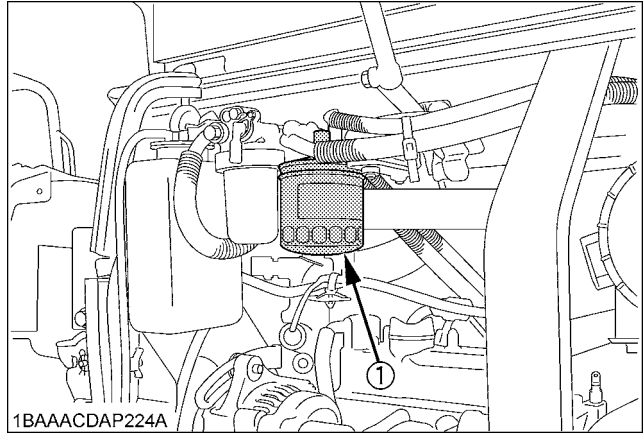

(1) Filter element

IMPORTANT :

- After exchange of the filter, the fuel system must be purged of air.

■ Replacing Hydraulic Return Filter Element (first replacement after 250 service hours)



CAUTION

To avoid personal injury:

- Remove the oil filter only after the oil in the hydraulic tank has cooled down.

1. Screw out the cover (1) using a filter wrench.
2. Remove and replace the return filter (3).
3. Check the condition of sealing ring (2) of the cap. Replace it if necessary.
4. Insert and mount the cover (1).

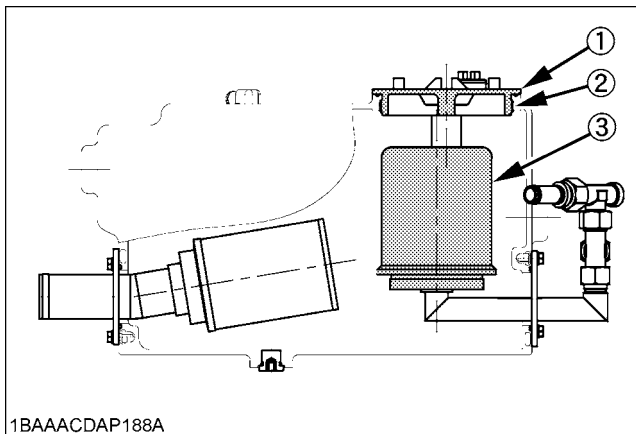

1BAAACDAP188A

- (1) Cover
- (2) Sealing ring
- (3) Return filter

IMPORTANT :

- Always check the oil level when replacing the filter cartridge.

EVERY 1000 SERVICE HOURS

Do all 50, 200 and 500 hour servicing at the same time.

■ Hydraulic Oil Check for Machines with Hydraulic Breakers

The hydraulic oil change after 1000 operating hours in the operator's manual is based on the type of work done. Following inspection measures are valid when hydraulic breakers are used:

1. Changing and filling up of hydraulic oil
 - (1) The hydraulic oil must be changed more often when breakers are used because the machine is subject to harder conditions than normal excavating work.
 - (2) Use only the recommended oils mentioned in the operator's manual when changing or filling with oil.
 - (3) When filling up oil, never mix oils of different makes.
2. Changing the return filter and oil
 - (1) The filter must be changed more often because of contamination resulting from the frequent assembly and disassembly of the hoses.
 - (2) Use the correct replacement filter.
 - (3) Oil change according to operating hours.

		Hydraulic oil	Return Filter	Suction Filter
Normal excavator work		every 1000 Hrs.	every 500Hrs.	1000 Hrs.
Breaker work portion	20%	evry 800 Hrs.	300 Hrs.	
	40%	evry 400 Hrs.		
	60%	evry 300 Hrs.	100 Hrs.	
	More than 80%	evry 200 Hrs.		

Hydraulic Oil Change(Including Replacing Suction Filter in Hydraulic Tank)

CAUTION

To avoid personal injury:

- Wait long enough for the hydraulic fluid to cool down. Then begin with the change of the hydraulic fluid.

1. Park the excavator on a firm, flat and level surface. Lower the attachments and dozer blade on the ground, release the cylinder pressure by actuating the levers and stop the engine.

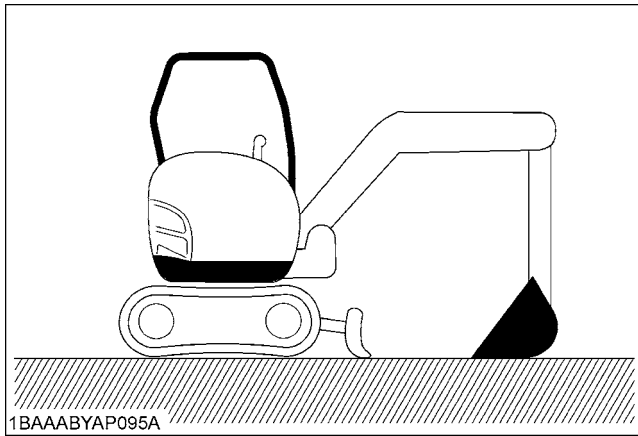

2. Remove the drain plug on the underside of the hydraulic tank and drain the oil.

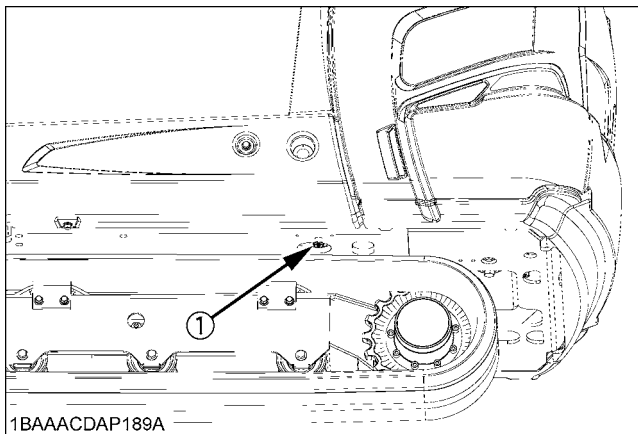

(1) Drain plug

3. Screw out the cover (1) using a filter wrench.
4. Remove the return filter from the hydraulic tank.
5. Screw off the suction filter (2).
If necessary, remove any residues with a clean, lint-free cloth.
6. Screw on the new suction filter by hand.

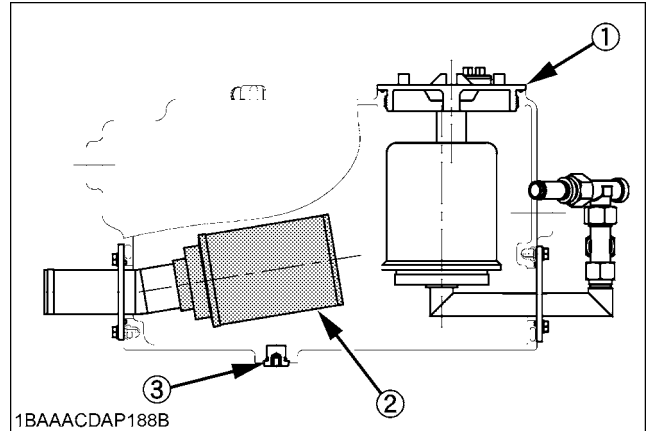

- (1) Cover
- (2) Suction filter
- (3) Drain plug

7. Fill oil through the oil filling opening on the top side of the tank.
8. Install the return filter.
9. Let the engine run and operate the boom, arm, bucket and boom swing device. Then bring the boom to the highest position, pull the arm, bucket inward and boom swing left end.
10. Fill oil again up to the center of the gauge.

Hydraulic oil volumes	Hydraulic tank	14.2 L
	Whole oil volumes	27 L

11. Install the hydraulic tank cover and tighten the oil filling plug.

EVERY 1000 SERVICE HOURS OR ONCE A YEAR

■ Replacing Air Filter Element

Open the engine cover and remove the dust cover.

Take out outer element and inner element (safety element).

Replace inner and outer element.

Installing the dust cover, be sure to its TOP mark (arrow) faces upward.

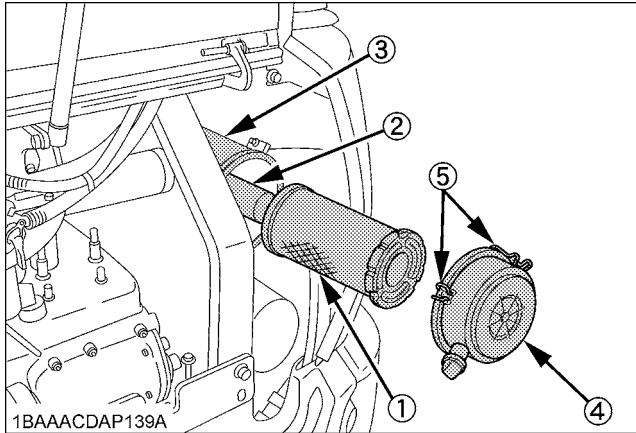

- (1) Outer element
- (2) Inner element (Safety element)
- (3) Case
- (4) Dust cover
- (5) Clamps

IMPORTANT :

- Shorten the replacement period if using in a place exposed to lots of dust or sandy areas.

EVERY 1500 SERVICE HOURS

■ Checking Fuel Injection Nozzle(Injection Pressure)

Consult your local KUBOTA Dealer for this service.

EVERY 2000 SERVICE HOURS

Do all 50, 200, 500 and 1000 hour servicing at the same time.

■ Changing Front Idler and Track Roller Oil

NOTE :

- Contact your KUBOTA dealer for details.

■ Checking Alternator and Starter Motor

NOTE :

- Contact your KUBOTA dealer for details.

EVERY 3000 SERVICE HOURS

■ Checking Injection Pump

Consult your local KUBOTA Dealer for this service.

ANNUAL SERVICE

■ Electrical Wiring and Fuses

Check the terminals periodically for proper connections. Loose wiring or damaged cables can cause improper functioning or short circuiting of the electrical system. Check wiring and replace damaged components immediately. If a fuse blows out soon after having been replaced, contact your nearest KUBOTA dealer. Do not use a fuse other than specified.

BIENNIAL SERVICING



CAUTION

To avoid personal injury:

- Do not loosen the radiator cap before the radiator has cooled down sufficiently. Then only loosen the cap and allow enough time for the pressure in the system to be released. Now remove the cap completely.

■ Replacing of Radiator Hoses

Replace radiator hoses and hose clamps every two years. If the hoses are swollen, hard or cracked, they must be replaced earlier.

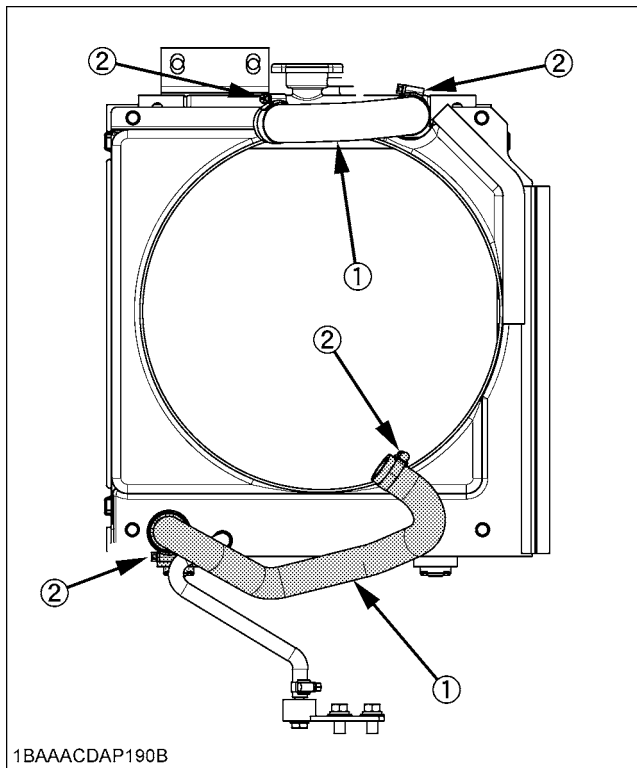

- (1) Radiator hoses
(2) Hose clamps

■ Changing Radiator Coolant



CAUTION

To avoid personal injury:

- When using anti-freeze, put on some protection such as rubber gloves (Anti-freeze contains poison.).
- If anti-freeze has been swallowed, seek medical attention at once.
- When anti-freeze comes in contact with the skin or clothing, wash it off immediately.
- Do not mix different types of Anti-freeze. The mixture can produce chemical reaction causing harmful substances.
- Anti-freeze is extremely flammable and explosive under certain conditions. Keep fire and children away from anti-freeze.
- When draining fluids from the engine, place some container underneath the engine body.
- Do not pour waste onto the grounds, down a drain, or into any water source.
- Also, observe the relevant environmental protection regulations when disposing of anti-freeze.
- Anti-freeze if swallowed is poisonous to people, animals and birds.

Stop the engine then remove the key and wait until machine has cooled down completely.

1. Open the drain plug on the bottom of the radiator and drain coolant completely, Should a reserve tank be equipped, disconnect the line from the tank floor and then open the drain cock.
2. To clean, rinse the radiator with water.
3. Close the drain plug and fill the radiator and the reserve tank with coolant fluid. Let the engine idle for about 5 min., stop the engine and remove the key then check the coolant level.
4. The machine has been shipped filled with 50% anti-freeze solution.

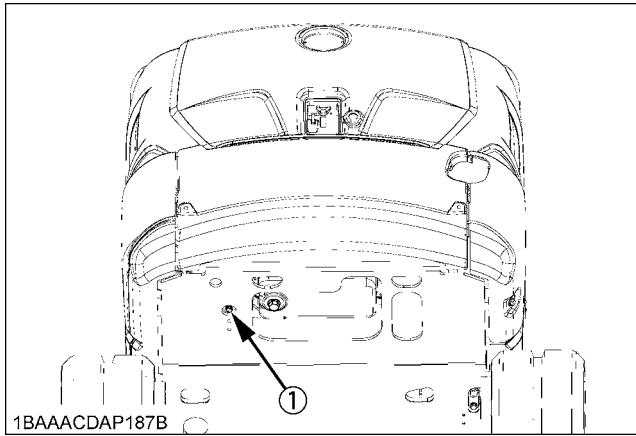

(1) Drain plug

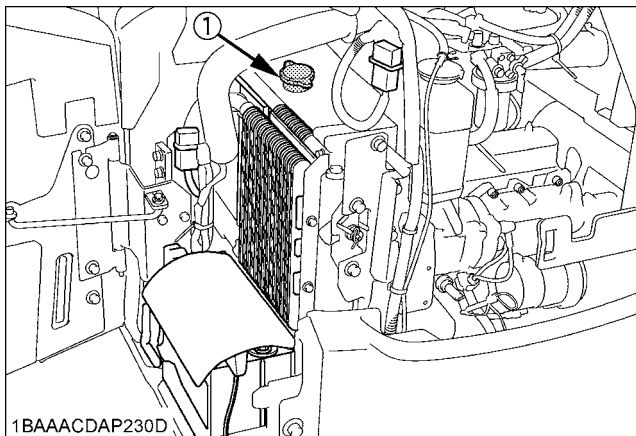

(1) Radiator cap

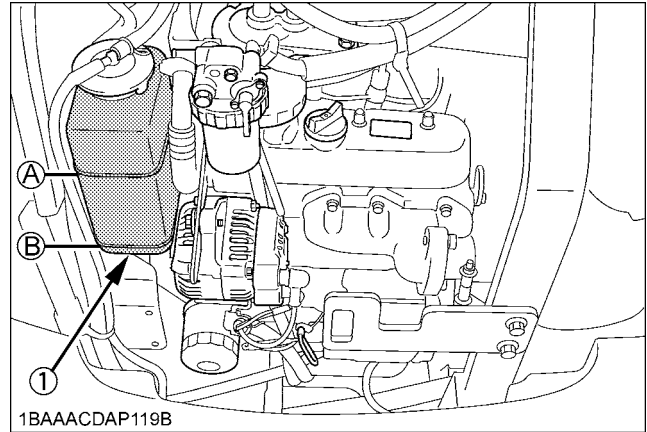

(1) Reserve tank

(A) "FULL"

(B) "LOW"

Radiator	approx. : 2.7 L
Reserve tank	approx. 0.56 L

IMPORTANT :

- Do not operate the engine without coolant.
- To fill the radiator system and the reserve tank, use fresh water and anti-freeze fluid.
- When the anti-freeze is mixed with water, the anti-freeze mixing ratio must be less than 50%
- Tighten the radiator cap properly. If the cap is loosely or not properly fitted, overheating of the engine can result due to coolant fluid loss.

■ Replacing Fuel Hose

Replace the hoses and clamps.
(Contact your local KUBOTA dealer for details.)

■ Replacing Intake Air line

Replace the hoses and clamps, if necessary.
(Contact your local KUBOTA dealer for details.)

OTHER ADJUSTMENTS AND REPLACEMENTS

PURGING FUEL SYSTEM

1. Fill up the excavator with fuel.
2. Turn the starter key to the position "RUN".
3. The air in the fuel system will automatically be purged within one minute.

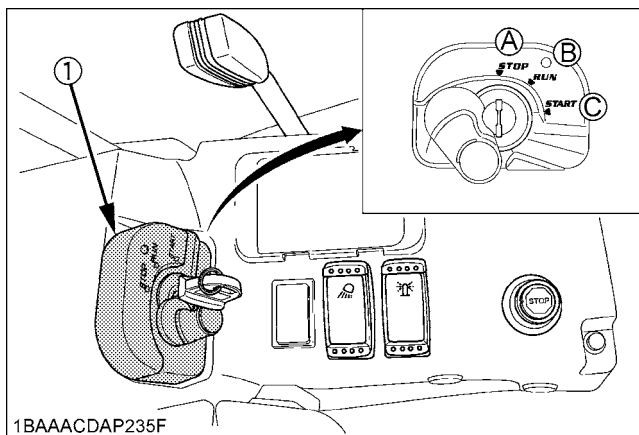

1BAAACDAP235F

(1) Starter switch

(A) "STOP"
(B) "RUN"
(C) "START"

IMPORTANT :

- If the purging was insufficient, the engine stops operating after starting. In this case repeat steps (2) to (3) again.

ADJUSTMENT OF TRACKS

■ Rubber Tracks

Tension the tracks as specified:

1. Apply grease (2) to the grease nipple (1).

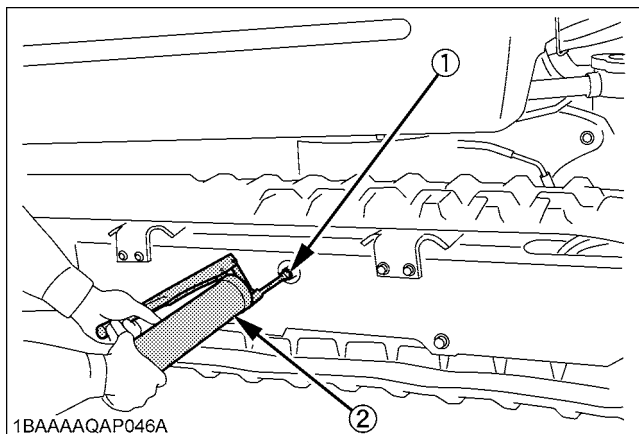

1BAAAAQAP046A

(1) Grease nipple
(2) Grease gun (Option)

2. Tension the track in the lifted position, so that the distance "A" (clearance between the center track roller and the track surface of the track) is 10 to 15 mm (see illustration) In this case, the track seam is positioned on the top center between the idler and the sprocket.



DANGER

To avoid serious injury or death:

- Do not work under the machine in this condition.
- For your safety do not rely on hydraulically supported devices, they may leak down and suddenly drop or be accidentally lowered.
- When lifting the machine itself with an attachment, place a safety block or safety post to prevent the machine from turning over. Keep the lock lever (unload lever) in the "LOCK" position.

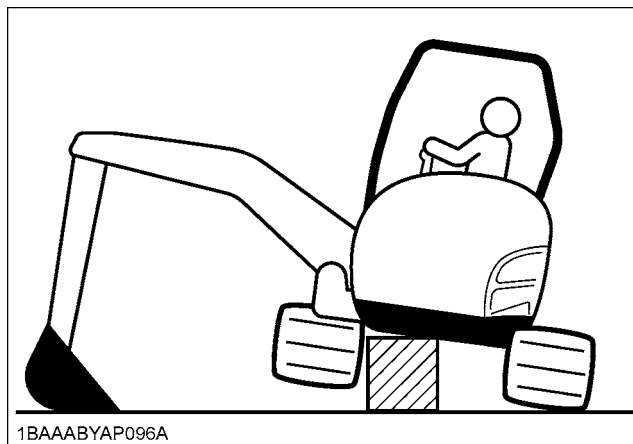

1BAAABYAP096A

[KX016-4]

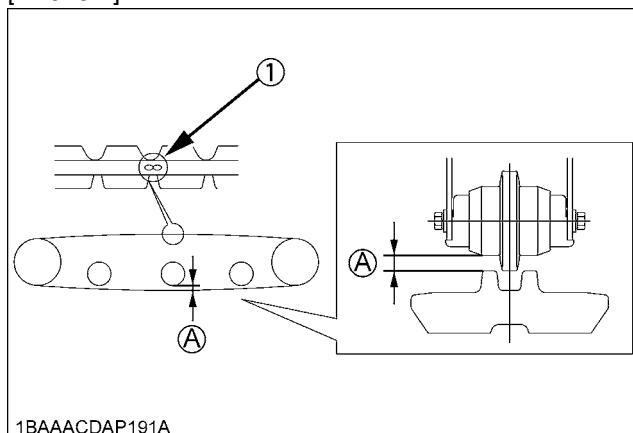

1BAAACDAP191A

(1) Seam (Mark "∞")

(A) "10 to 15 mm"

[KX018-4]

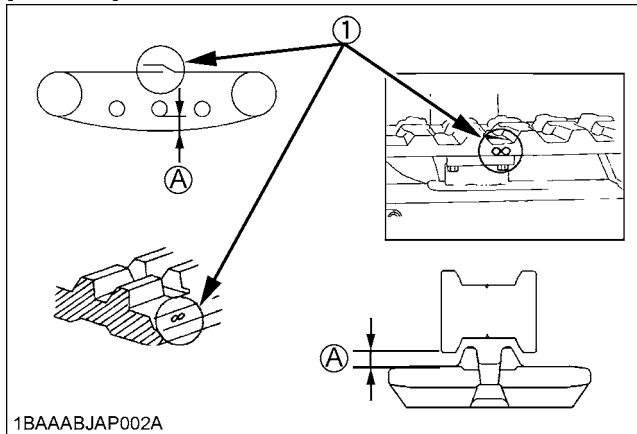

1BAAABJAP002A

(1) Seam (Mark "∞")

(A) "10 to 15 mm"

IMPORTANT :

- Track seam
The ends of the rubber track are joined with a seam. When adjusting the tracks, the seam must be positioned on the top midway between the idler and the sprocket. By machines equipped with an upper roller, the seam mark should be positioned over the upper roller.
If the seam is positioned incorrectly, the tracks will be tensioned to loosely, and a further readjustment will be necessary.
- Rotate the track after adjustment one to two times to check the tension. To loosen the rubber tracks, follow the procedure below.
- Additional following points are to be observed when adjusting rubber tracks.
 - (1) If the track loosen more than 25 mm (1.0 in.), readjust them.
 - (2) Check track tension 30 hours after initial use and readjust if necessary. Check and adjust thereafter every 50 service hours.

Special Information when Using Rubber Tracks

1. When turning, make a slow swing turn. Avoid spin turns to reduce lug wear and entry of dirt.
2. The relief valve may be activated if too much dirt and sand clog the tracks. In this case move the machine for a short distance straight backwards to let the earth and sand fall off, then a turn can be made.
3. Avoid using rubber track on riverbeds, stony underground, ferro-concrete and on iron plates. The rubber can damage as well as increase wear on the tracks.

◆ To loosen the tracks, follow following procedure:**CAUTION****To avoid personal injury:**

- Do not loosen the grease nipple completely or too quickly. Otherwise grease under high pressure in the tension cylinder could squirt out.
- Make sure that no obstacles, such as stones are caught in the track. Remove such obstacles before adjusting the track tension.

1. Loosen the bolt of the cover and remove the cover.
2. Using a socket wrench, loosen the grease nipple a few turns.
3. When grease oozes out from the thread, rotate the track and loosen the track in the lifted position.

After adjustment is completed:

Using the socket wrench, tighten the grease nipple.

Tightening torque must be between 1000 to 1100 kgf-cm (72 to 80 ft-lbs).

IMPORTANT :

- If the tracks are too tight, wear is increased.
- If the tracks are too loose, the track pads may collide with the sprocket, wear is increased.
The track may dislocate or come off.
- Clean the track after every use.
- Should the track tension be high due to sticking mud, lift the track with the help of the boom, arm and bucket, idle the engine and remove mud from the track, especially from the openings of the link plate carefully.

CHANGING THE BUCKET



CAUTION

To avoid personal injury:

- When the coupling pins are removed or installed, chips may come off. Always use gloves, goggles and a helmet.
- When the change of the equipment must be performed with the engine running, always work as a 2-person team. One person sits in the operator's seat and the other works on the machine.
- Do not use your fingers to center the holes, since they may be injured or even cut in case of sudden or uncontrolled movements.
- Read the manual of the attachment to do a correct operation safely when other attachments are installed instead of Kubota specified bucket.

FUSES



CAUTION

To avoid personal injury:

- When changing fuse, stop the engine and turn the key in position "STOP".

■ Replacing Fuses

1. Remove the cover of the fuse box.
2. Replace the burnt out fuse with a fuse having the same capacity.

■ Fuse Capacities and Circuits

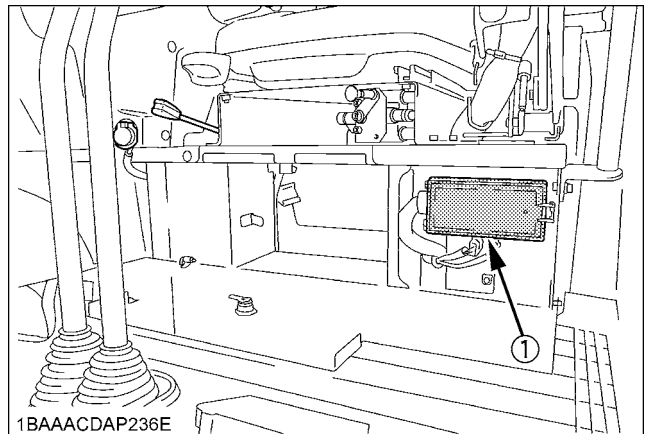

(1) Fuse box

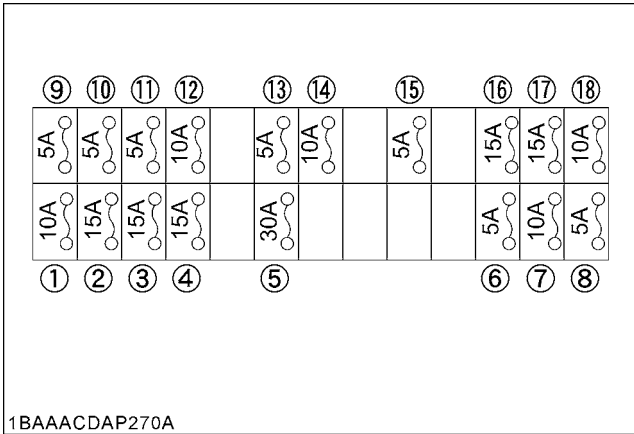

(1) Fuse box

1	Blow Motor	10	Lock Lever
2	Radio (AC)	11	Fuel Pump
3	Wiper / Washer	12	ECU (AC)
4	Electrical Outlet	13	Relay Source
5	Engine Stop	14	Alternator
6	ECU (+B)	15	Room Light
7	Horn Switch	16	Beacon
8	Meter (+B)	17	Work Light
9	Starter	18	Horn

■ Auxiliary Electric

Max power is less than 120 W.

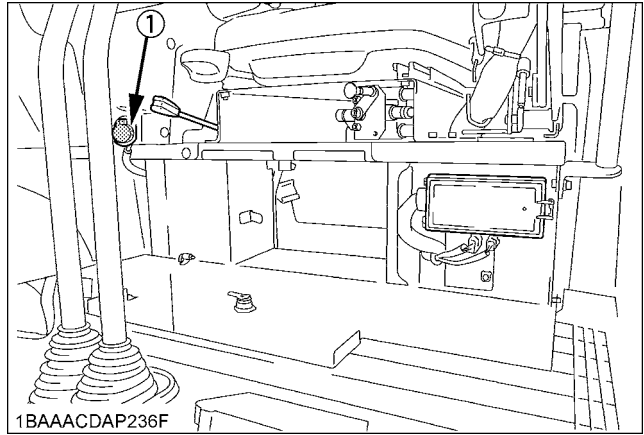

(1) Auxiliary electric A

NOTE :

- If the machine keeps idling on the reserve power, the battery gets discharged. Raise the engine rpm.

■ Slow Blow Fuse

Slow blow fuse is provided to protect the electrical circuits. If the fusible link is blown, check the electrical circuits for trouble and then replace with a new compatible slow blow fuse.

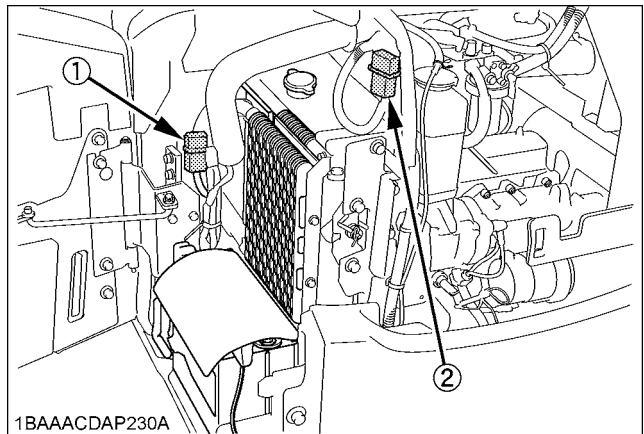

(1) Slow blow fuse (50 A)
 (2) Slow blow fuse (60 A)

TROUBLESHOOTING











If the mini-excavator does not show the desired performance, or when trouble arises, refer to the table below and undertake appropriate measures.

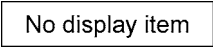

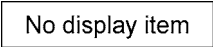

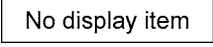

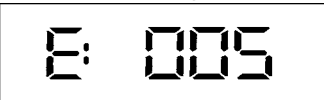

Trouble		Cause	Solution
Engine	Starting difficulties	Lock levers in "UNLOCK" position	* Bring lock lever into "LOCK" position
		Fuel is too viscous	* Check fuel tank and filter * Remove impurities and water * If necessary, replace filter
		Air or water in the fuel system	* Remove water from the fuel tank * Check fuel pipe joint bolts and nuts for looseness * Purging of the fuel system (for fuel filter and injection pump see "PURGING OF THE FUEL SYSTEM" in the chapter "OTHER ADJUSTMENTS AND REPLACEMENTS".)
		Oil viscosity is too high the engine runs sluggishly in winter	* Pour hot water over the radiator
		Battery is almost dead; insufficient compression	* Recharge battery
	Insufficient engine power	Low fuel level	* Check fuel and add if necessary
		Clogged air cleaner	* Clean the air filter element
	Engine suddenly stops	Low fuel level	* Check fuel and add if necessary * Purge the fuel system
	Abnormal exhaust gas colour	Poor fuel	* Use high quality fuel
		Too much engine oil	* Drain engine oil to prescribed oil level
	Water temperature in red zone (Overheating)	Defective seal of the water pump	* Replace
		Worn or torn fan belt	* Adjust or replace
		Thermostat is defect	* Replace
		Coolant level too low	* Fill to prescribed level
		Radiator grill or fins are clogged	* Clean
		Coolant is contaminated with rust from the cylinder head or crank case	* Replace coolant fluid and add anti-rust
		Defective radiator cap (Evaporation)	* Replace
		Corroded coolant pipes	* Clean
		Continuous operation under full load	* Reduce load
		Cylinder head gasket is damaged (Coolant loss)	* Replace
Engine oil level too low		* Fill to prescribed level	
Maladjustment of fuel injection		* Readjust ignition timing	
Use of poor fuel		* Use prescribed fuel	









Hydraulic System	Boom, arm, bucket, drive, swing and dozer power is too low	Hydraulic oil level too low	* Add oil
		Leakages of hoses and / or joints	*Replace hose or joint
	Swing motor and front attachment does not work	Lock lever in "LOCK" position	*Bring lock lever into "UNLOCK" position
Drive System	Deviation of drive direction	Blocked through stones	* Remove
		Track too loose or too tight	* Adjust accordingly
	Drive lever does not move	Lock lever in "LOCK" position	* Bring lock lever into "UNLOCK" position









KUBOTA I.C.S. NAVIGATION LIST OF MESSAGES

If an error occurs with the machine, one of the following messages appears in the LCD display.
In case of a trouble, immediately contact your local dealer for inspection and repair.

	LCD display	LED	Problem / Error	Solution #1	Solution #2
1	CAN system error 		The Controller Area Network (CAN) has developed a fault. Measured values may be incorrect and switches may not function.	The machine can be started and driven. Do not perform any work with the machine.	Inform your KUBOTA dealer immediately.
2	Feed fuel 		This message appears when the fuel level is low and prompts the operator to refuel.	---	Refuel the excavator.
3	Periodic check soon (notice) 		This message appears 10 hours before the periodic check interval. This message means that the regular service is due shortly.	Operate the machine as usual.	Ask your KUBOTA dealer about the relevant parts. Run the maintenance procedure.
4	Periodic check passed (warning) 		This message means that the regular service is due.	The machine can be operated but service must be carried out urgently.	Ask your KUBOTA dealer about the relevant parts. Run the maintenance procedure.
5	Warning temperature rising 		The temperature of the coolant is higher than normal.	Operate the machine only with reduced loads until the temperature is normal again.	---
6	---	---	---	---	---
7	---	---	---	---	---
8	---	---	---	---	---

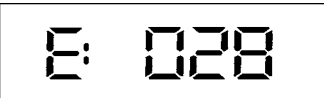
	LED Display	LED	Problem / Error	Solution #1	Solution #2
9	Clock setting request No display item		Power was interrupted and the clock now has to be set again.	In order to set the clock, press the user setting switch.	---
10	---	---	---	---	---
11	Raise the control lever lock No display item	 (yellow)	This message indicates a step in a procedure.	Raise the lock lever (unload lever); the indicator goes out.	---
12	Pull out the key No display item		The key must be pulled out.	Pull out the key.	---
13	Lower the control lever lock No display item	 (yellow)	This message indicates a step in a procedure.	Lower the lock lever (unload lever); the indicator goes out.	---
14	Oil pressure too low E: 014	 (red) + 	The engine oil pressure is too low.	Stop the engine immediately. The engine may have developed a fault.	Inform your KUBOTA dealer immediately.
15	Overheat E: 015		The machine is overheated and must cool off by idling.	Allow the machine to cool off by idling. Do not switch the engine off as the coolant could then boil over.	Clean the radiator and check the coolant. Refill the radiator with coolant by its boiled-over amount. Unclog the radiator and other components before use again. Check also the hydraulic system for oil leak and other troubles. If an oil leak is found, immediately contact your local dealer for repair.
16	Charging system error E: 016	 (red) + 	The charging system has developed a fault.	Check the V-belt. When the V-belt is OK, let the engine run until the indicator goes out.	If the indicator does not go out, inform your KUBOTA dealer immediately.

	LCD Display	LED	Problem / Error	Solution #1	Solution #2
17	Fuel sensor error 	 (red)	The fuel sensor has developed a fault; the fuel gauge does not appear in the display.	Press the display selector switch to return to the default display.	Inform your KUBOTA dealer immediately.
18	Water temperature sensor error 	 (red)	The coolant temperature sensor has developed a fault; the coolant temperature gauge does not appear in the display.	Press the display selector switch to return to the default display. The functions of the machine are stable but overheating cannot be excluded.	Inform your KUBOTA dealer immediately.
19	---	---	---	---	---
20	Lever lock system error 	 (red)	The electrical system in the lock lever (unload lever) has developed a fault.	The engine can be started but the machine cannot be set in motion.	Inform your KUBOTA dealer immediately.
21	Travel 2 speed system error 	 (red)	The electrical system in the travel speed has developed a fault.	The machine can only be set in motion at low speed.	Inform your KUBOTA dealer immediately.
22	---	---	---	---	---
23	---	---	---	---	---
24	---	---	---	---	---

	LCD Display	LED	Problem / Error	Solution #1	Solution #2
25	<p>Overvoltage</p> 	 (red)	<p>This is a warning that a higher voltage (from a 24-V battery, for example) is being applied to the electric circuit, or that there is a problem with the alternator.</p>	<p>Switch the engine off immediately and check the battery and the alternator. Restart the engine.</p>	<p>If the indicator lights up again after restarting, inform your KUBOTA dealer immediately.</p>
26	---	---	---	---	---
27	<p>External 5-V system error</p> 	 (red)	<p>The 5-V sensor supply line has developed a system fault. The main functions are not available.</p>	<p>The machine can be started and driven. Do not perform any work with the machine.</p>	<p>Inform your KUBOTA dealer immediately.</p>
28	<p>External 12-V system error</p> 	 (red)	<p>The 12-V sensor supply line has developed a system fault. The main functions are not available.</p>	<p>The machine can be started and driven. Do not perform any work with the machine.</p>	<p>Inform your KUBOTA dealer immediately.</p>
29	<p>Starting the engine</p> 	 (yellow)	<p>This message indicates a step in a procedure.</p>	<p>Start the engine; the indicator goes out.</p>	---

◆ **Service hour meter**

When the hour meter has counted up to the hours circled in the maintenance list below, the message appears. The message shows up as follows.

No.	LCD Display	Check points		Measures	Hour meter indicator								Intervals		
					50	100	250	300	500	550	600	750		800	1000
1	C: 001	Engine oil		change	●			○		○			○		every 250 hrs
2	C: 002	Hydraulic oil												○	every 1000 hrs
3	C: 003	Air filter element	Outer element	replace									○	every 1000 hrs	
			Inner element										○	every 1000 hrs	
4	C: 004	Fuel filter cartridge		replace					○				○	every 500 hrs	
5	C: 005	Engine oil filter			●			○		○			○	every 250 hrs	
6	C: 006	Drive unit oil		Change	●				○				○	every 500 hrs	
7	C: 007	Hydraulic return filter cartridge		replace			●					○		every 500 hrs	
8	C: 008	Hydraulic suction filter element												○	every 1000 hrs
9															
10	C: 010	Front idler and track roller oil		change										every 2000 hrs	

● First operation

The maintenance message appears. The message shows up as follows.



(The maintenance message reappears on the hour meter designated next.)

NOTE :

- The maintenance message disappears automatically in about 10 seconds.
 - The maintenance (periodic check) message can be preset to be made disappear manually only.
- ◆ In case the service hour meter replaced due to any trouble with it, the meter is set to "0". Contact your KUBOTA dealer for details.

OPERATION UNDER COLD WEATHER CONDITIONS

PREPARATION FOR OPERATION IN COLD WEATHER

1. Replace engine oil and hydraulic oil with those of viscosities suitable for cold weather.
2. In cold weather, battery power drops, and the battery fluid may freeze if the battery is not sufficiently charged. To prevent the battery fluid from freezing, be sure to keep the battery charged at least 75% or more of its capacity after operation. To ease next starting, it is recommended to keep the battery stored in closed or heated rooms. If the battery fluid level is too low, do not add after operation, but add with the engine running before the next operation.
3. Add anti-freeze to coolant in the radiator and reserve tank, if the ambient temperature is expected to drop below 0°C. Mixing ratio of water and anti-freeze depends on the expected ambient temperature.

- Mixing ratio between water and anti-freeze

Ambient Temperature (°C)	-5 (+23)	-10 (+14)	-15 (+5)	-20 (-4)	-25 (-13)	-30 (-22)	-35 (-31)
Antifreeze %	30	30	30	35	40	45	50
Water %	70	70	70	65	60	55	50

IMPORTANT :

- Use permanent anti-freeze or long-life coolant.
- Drain the coolant completely and clean the radiator inside then fill with the water and anti-freeze mixture.
- As the anti-freeze also acts as an anti-corrosive, it is not necessary to add an additive to the water and anti-freeze mixture.
- See "Checking Coolant Level" under "DAILY CHECKS" in "MAINTENANCE" for radiator fill volumes.

PROCEDURE AFTER DONE WORK

Clean the excavator thoroughly after work and wipe dry. Otherwise mud and earth on the crawlers could freeze if the temperature drops below the 0°C (32°F) mark. Operation of the excavator is then not possible. Store the excavator in a dry place; if not possible, store on wooden planks or on mats. If the excavator is kept on damp or muddy ground, the crawlers could freeze overnight. Operation of the excavator is then not possible. Furthermore the reduction gear may be damaged. Additionally, the piston rods of the hydraulic cylinders must be rubbed dry. Otherwise severe damage could occur if dirty water seeps through the seals.

LONG STORAGE



CAUTION

To avoid personal injury:

- Do not clean the excavator with the engine running.
- To avoid the danger of exhaust fume poisoning, do not operate the engine in a closed building without proper ventilation.
- When storing, remove the key from the starter switch to avoid unauthorized persons from operating the excavator and getting injured.
- Bring the excavator on a firm, flat, and level surface. Lower the attachments and dozer blade on the ground.

■ Should the Excavator be Stored for a Longer Period of Time, Observe Following Procedures:

1. The whole excavator should be cleaned thoroughly and in all cases stored indoors. If the excavator has to be kept outdoors, lay out wooden planks on even ground, place the excavator on the planks and cover completely.
2. Do an oil change and grease the excavator.
3. Heavily grease the visible section of the cylinder rods.
4. Remove the battery and store indoors.
5. If it is expected that the temperature will sink below the 0°C (32°F) mark, add anti-freeze or drain coolant completely.

IMPORTANT :

- Wash the excavator after stopping the engine.
If you wash the excavator while running the engine, splashing water gets into the air cleaner through its intake and cause engine damage.
Carefully, wash and do not splash water over the air cleaner while the engine is running.

■ Observe Following Procedures when the Machine is to be Operated after Long Term Storage.

1. Wipe off the grease from the hydraulic cylinder rods.
2. Turn on the engine and operate the attachments and the drive mechanisms under no load in order to circulate the hydraulic oil.
(If the machine is stored for longer than one month, do steps 1 and 2 once every month.)

Periodic replacement of important component parts

To ensure safety in operation, you are strongly requested to inspect and service the machine at regular intervals. For added safety, ask your KUBOTA dealer to replace the following important component parts.

These parts are prone to degradation in material or subject to wear and tear with time. It is difficult to judge how much they have been affected at regular inspection. It is therefore necessary to replace them with new ones, whether wear is visible or not after a specified time of use.

If any of them is found to be worn before the specified use, they must be repaired or replaced the same as other parts.

If any of the hose clamps are found deformed or cracked, the hose clamps must also be replaced.

For the hydraulic hoses other than the ones to be replaced periodically, inspect them for the following points. If found loose or very worn, tighten and / or replace the hose.

When replacing the hydraulic hoses, change their O rings and sealing components with new ones.

For replacement of the important parts, contact your KUBOTA dealer.

- At the following periodic inspections, check the fuel hoses and hydraulic hoses as well.

Inspection Interval	Check points
Daily Checks	Oil leak at fuel and hydraulic hose connections and points
Every month	Oil leak at fuel and hydraulic hose connections and points Damages at fuel and hydraulic hose (cracks, chafing)
Every year	Oil leak at fuel and hydraulic hose connections and points Interference, deformation, degradation, twist and other damages (cracks, chafing) of fuel and hydraulic hoses

List of important component parts

No.	Component parts	Used place	Q'ty	Period
1	Fuel hose	Fuel tank - Fuel filter	1	Every 2 years or 4000 hours
		Fuel filter - Fuel pump	1	
		Fuel pump - Fuel nozzle	1	
		Fuel nozzle - Fuel tank	2	
2	Hydraulic hose (suction)	Tank - Pipe	1	
		Pipe - Main pump	1	
3	Hydraulic hose (delivery)	Main pump - Control valve	3	
		Main pump - Change valve	1	
4	Hydraulic hose (Boom cylinder)	Control valve - Hose joint	2	
		Hose joint - Boom cylinder	2	
5	Hydraulic hose (Arm cylinder)	Control valve - Hose joint	2	
		Hose joint - Arm cylinder	2	
6	Hydraulic hose (Bucket cylinder)	Control valve - Hose joint	2	
		Hose joint - Bucket cylinder	2	
7	Hydraulic hose (Swing cylinder)	Control valve - Swing cylinder	2	
8	Hydraulic hose (Dozer cylinder)	Control valve - Rotary joint	2	
		Rotary joint - Pipe	2	
		Pipe - Dozer cylinder	2	
9	Hydraulic hose (AUX port)	Control valve - Hose joint	2	
		Hose joint - Adapter	2	
10	Hydraulic hose (Swivel motor)	Control valve - Swivel motor	2	

To prevent serious damage to the hydraulic system, use only a KUBOTA genuine hydraulic hose.

RECOMMENDED OILS

IMPORTANT :

1. Before delivery the hydraulic oil used was an ISO 46 viscosity grade.
2. Use engine oil API service classification CD, CE or CF.
3. Use SAE 90 (API, CLA/GL5) as drive unit oil for all seasons.

	Application	Viscosity	Shell	Mobil	Exxon	MIL-Standard
Engine oil	In winter or by low temperatures	SAE 10W	Shell Rotella T10W Shell Rimula 10W	Mobil Delvac 1310	XD-3 10W XD-3 Extra 10W	MIL-L-2104C MIL-L-2104D
		SAE 20W	Shell Rotella T20W-2 Shell Rimula 20W-2	Mobil Delvac 1320	XD-3 20W-20 XD-3 Extra 20W-20	
	In summer or by high ambient temperatures	SAE 30	Shell Rotella T30 Shell Rimula 30	Mobil Delvac 1330	XD-3 30 XD-3 Extra 30	
		SAE 40	Shell Rotella T40 Shell Rimula 40	Mobil Delvac 1340	XD-3 40 XD-3 Extra 40	
		SAE 50	Shell Rimula 50	Mobil Delvac 1350		
All- Season engine oil	Multi-purpose	Shell Rotella T15W-40		XD-3 15W-40 XD-3 Extra 15W-40		
Gear oil	In winter or by low temperatures	SAE 75		Mobilube HD80W-90		MIL-L-2105C
			Shell Oil S8643			
	In summer or by high ambient temperatures	SAE 80		Mobilube HD80W-90		MIL-L-2105C
			Shell Spirax HD80W			
		SAE 90		Mobilube 46		
	All-weather gear oil	Multi-purpose		Shell Spirax HD90	Mobilube HD80W-90	
			Shell Spirax HD140	Mobilube HD85W-140		MIL-L-2105C
		Shell Spirax HD80W Shell Spirax HD85W	Mobilube HD80W-90	GX80W-90	MIL-L-2105C	
Hydraulic oil	In winter or by low temperatures	ISO 32	Shell Tellus T32	Mobil DTE-Oil 13	NUTO H32	
		ISO 46	Shell Tellus T46	Mobil DTE-Oil 15	NUTO H46	
	In summer or by high ambient temperatures	ISO 68	Shell Tellus T68	Mobil DTE-Oil 16	NUTO H68	
Grease		Shell Alvania EP2	Mobilux EP2	BEACON Q2		
Fuel			Light oil No. 2-D (ASTM D975)			
Fuel under -5°C (+23°F)			Light oil No. 1-D (ASTM D975)			

APPENDICES

MAIN DIMENSIONS

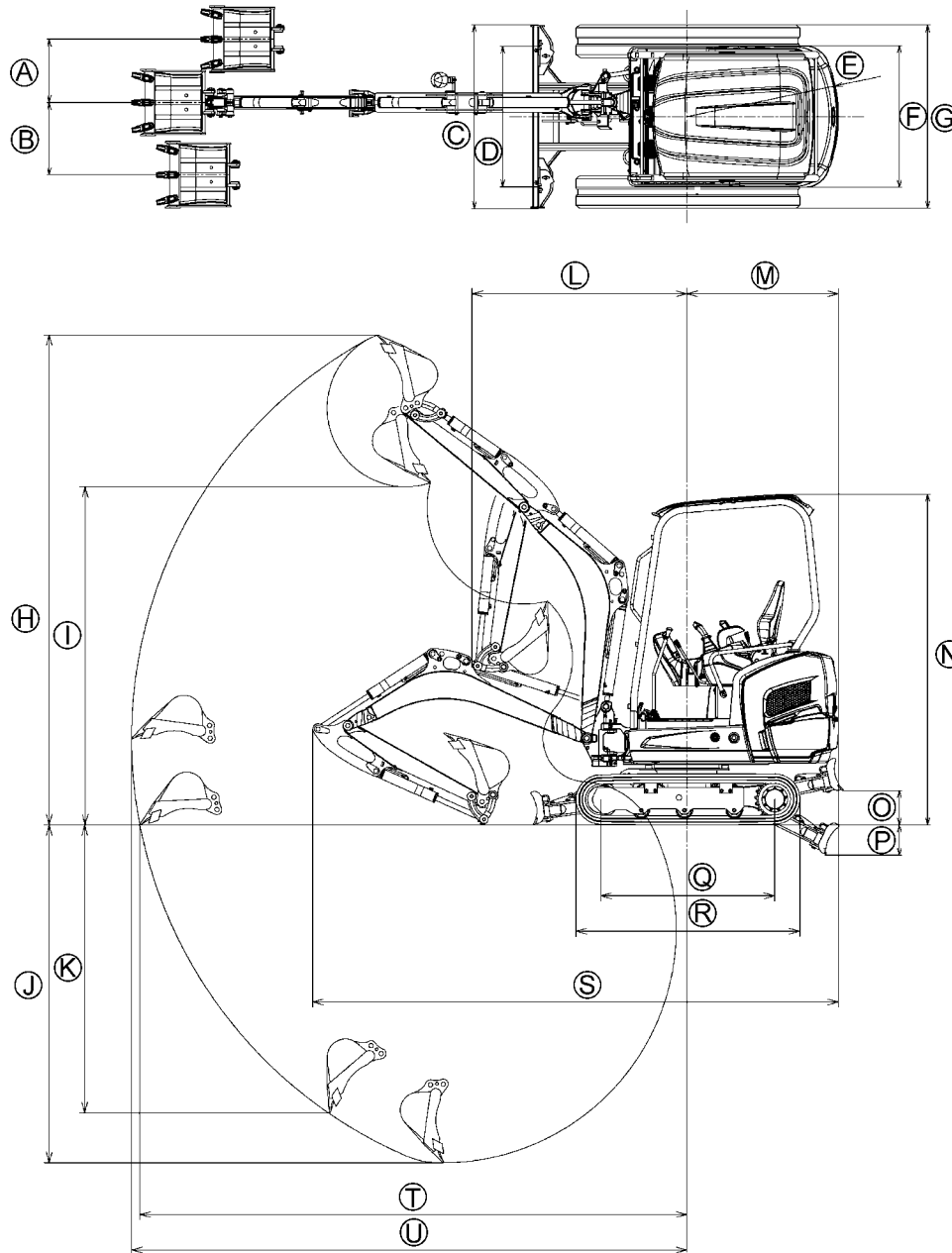

1BAAACDAP272A

With rubber track.

mm

	(A)	(B)	(C)	(D)	(E)	(F)	(G)	(H)	(I)	(J)	(K)	(L)
KX016-4	450	510	1240	990	1070	990	1240	3360	2290	2250	1900	1490
KX018-4			1300				1300	3460	2380	2380	2030	1480
	(M)	(N)	(O)	(P)	(Q)	(R)	(S)	(T)	(U)			
KX016-4	1070	2330	240	230	1090	1450	3710	3730	3790			
KX018-4			230		1230	1590		3860	3920			

LIFTING CAPACITY

- The lifting capacities are based on ISO 10567 and do not exceed 75% of the static tilt load of the machine or 87% of the hydraulic lifting capacity of the machine.
- The strokes are as follows.
 - The load point corresponds to the front pin part of the arm.
 - The machine positions are (i) over - front (Blade down), (ii) over - front (Blade up), and (iii) over - side.
 - The operating cylinder is the boom cylinder.
- The bucket of the excavator, the hook, the sling and other lifting accessories are taken into consideration for the loads.

Machine conditions:

No bucket, all others according to the standard regulations.



WARNING

To avoid personal injury or death:

- No loads greater than those values mentioned in the lifting capacity tables are to be lifted.
- The values mentioned in the table are valid only on even, hard grounds. When lifting on soft ground, the machine can tip over due to the load being concentrated only on one side of the machine.
- The table values are calculated at the end of the arm without the bucket. In order to find the allowable loads for machines with bucket, the bucket weight must be subtracted from the values in the table.

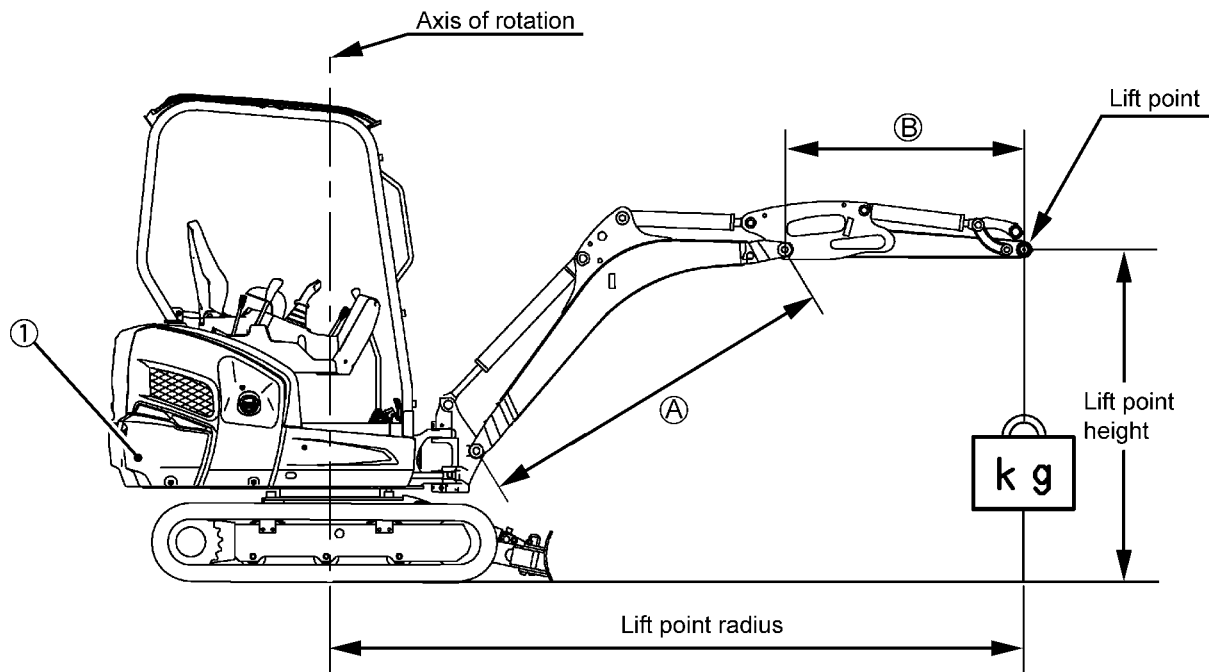

1BAAACDAP269A

	(1) Counter weight	(A)	(B)
KX016-4	10 kg	1.69 m	0.95 m
KX018-4	60 kg	1.69 m	1.09 m

KX016-4 STANDARD ARM
RUBBER TRACK
ROPS CANOPY
STANDARD TRACK WIDTH

LIFTING CAPACITY OVER-FRONT BLADE DOWN
kN (kg)

LIFT POINT HEIGHT (m)	LIFT POINT RADIUS (m)							
	MIN.	1.0	1.5	2.0	2.5	3.0	MAX.	
GL	2.5							
	2.0				2.6 (270)			
	1.0			4.5 (460)	3.5 (360)	2.9 (300)		
	0.0		4.7 (480)	5.3 (540)	3.8 (390)	2.8 (290)		
	-1.0	8.5 (870)	5.9 (600)	4.0 (410)	2.8 (290)			
	-1.5		4.3 (440)	2.8 (290)				
	-2.0							

KX018-4 STANDARD ARM
RUBBER TRACK
ROPS CANOPY
STANDARD TRACK WIDTH

LIFTING CAPACITY OVER-FRONT BLADE DOWN
kN (kg)

LIFT POINT HEIGHT (m)	LIFT POINT RADIUS (m)							
	MIN.	1.0	1.5	2.0	2.5	3.0	MAX.	
GL	2.5				2.6 (270)			
	2.0				2.5 (250)			
	1.0			6.5 (660)	4.3 (440)	3.5 (360)	3.0 (310)	
	0.0		6.1 (620)	5.8 (590)	4.1 (420)	3.1 (320)		
	-1.0	9.1 (930)	6.8 (690)	4.5 (460)	3.2 (330)			
	-1.5		11.4 (1160)	5.2 (530)	3.4 (350)			
	-2.0							

LIFTING CAPACITY OVER-FRONT BLADE UP
kN (kg)

LIFT POINT HEIGHT (m)	LIFT POINT RADIUS (m)							
	MIN.	1.0	1.5	2.0	2.5	3.0	MAX.	
GL	2.5							
	2.0				2.5 (250)			
	1.0			3.2 (330)	2.4 (240)	1.8 (180)		
	0.0		4.5 (460)	2.9 (300)	2.2 (220)	1.7 (170)		
	-1.0	8.5 (870)	4.5 (460)	2.8 (290)	2.2 (220)			
	-1.5		4.3 (440)	2.8 (290)				
	-2.0							

LIFTING CAPACITY OVER-FRONT BLADE UP
kN (kg)

LIFT POINT HEIGHT (m)	LIFT POINT RADIUS (m)							
	MIN.	1.0	1.5	2.0	2.5	3.0	MAX.	
GL	2.5				2.6 (270)			
	2.0				2.5 (250)			
	1.0			6.5 (660)	4.3 (440)	3.0 (310)	2.4 (240)	
	0.0		6.1 (620)	3.9 (400)	2.8 (290)	2.2 (220)		
	-1.0	9.1 (930)	6.2 (630)	3.9 (400)	2.8 (290)			
	-1.5		11.4 (1160)	5.2 (530)	3.4 (350)			
	-2.0							

LIFTING CAPACITY OVER-SIDE
kN (kg)

LIFT POINT HEIGHT (m)	LIFT POINT RADIUS (m)							
	MIN.	1.0	1.5	2.0	2.5	3.0	MAX.	
GL	2.5							
	2.0				2.5 (250)			
	1.0			3.2 (330)	2.4 (240)	1.8 (180)		
	0.0		4.4 (450)	2.9 (300)	2.2 (220)	1.7 (170)		
	-1.0	8.5 (870)	4.4 (450)	2.8 (290)	2.2 (220)			
	-1.5		4.3 (440)	2.8 (290)				
	-2.0							

LIFTING CAPACITY OVER-SIDE
kN (kg)

LIFT POINT HEIGHT (m)	LIFT POINT RADIUS (m)							
	MIN.	1.0	1.5	2.0	2.5	3.0	MAX.	
GL	2.5				2.6 (270)			
	2.0				2.5 (250)			
	1.0			6.5 (660)	4.3 (440)	3.1 (320)	2.4 (240)	
	0.0		6.1 (620)	4.0 (410)	2.9 (300)	2.3 (230)		
	-1.0	9.1 (930)	6.3 (640)	3.9 (400)	2.8 (290)			
	-1.5		11.4 (1160)	5.2 (530)	3.4 (350)			
	-2.0							



- U.S.A. : **KUBOTA TRACTOR CORPORATION**
3401 Del Amo Blvd., Torrance, CA 90503, U.S.A.
Telephone : (310)370-3370
- Western Division : 1175 S. Guild Av., Lodi, CA 95240
Telephone : (209)334-9910
- Central Division : 14855 FAA Blvd., Fort Worth, TX 76155
Telephone : (817)571-0900
- Northern Division : 6300 at One Kubota Way, Groveport, OH 43125
Telephone : (614)835-1100
- Southeast Division : 1025 Northbrook Parkway, Suwanee, GA 30024
Telephone : (770)995-8855
- Canada : **KUBOTA CANADA LTD.**
5900 14th Avenue, Markham, Ontario, L3S 4K4, Canada
Telephone : (905)294-7477
- Richmond Distribution Center : 2620 Viscount Way, Richmond, B.C. V6V 1N1
Telephone : (604)270-9286
- Drummondville Distribution Center : 5705 Place Kubota, Drummondville, Québec, J2B 6B4
Telephone : (819)478-7151
- France : **KUBOTA EUROPE S.A.S**
19-25, Rue Jules Verducruysse, Z.I. BP88, 95101 Argenteuil Cedex, France
Telephone : (33)1-3426-3434
- Italy : **KUBOTA EUROPE S.A.S Italy Branch**
Via Grandi, 29 20068 Peschiera Borrome (MI) Italy
Telephone : (39)02-51650377
- Germany : **KUBOTA BAUMASCHINEN GmbH**
Steinhauser str, 100, 66482 Zweibrucken Rheinlandpfalz Germany
Telephone : (49)6332-4870100
- U.K. : **KUBOTA (U.K.) LTD.**
Dormer Road, Thame, Oxfordshire, OX9 3UN, U.K.
Telephone : (44)1844-214500
- Australia : **KUBOTA TRACTOR AUSTRALIA PTY LTD.**
25-29 Permas Way, Truganina, VIC 3029, Australia
Telephone : (61)-3-9394-4400
- Malaysia : **SIME KUBOTA SDN. BHD.**
No.3 Jalan Sepadu 25/123 Taman Perindustrian Axis,
Seksyen 25, 40400 Shah Alam, Selangor Darul Ehsan Malasia
Telephone : (60)3-736-1388
- Philippines: **KUBOTA PHILIPPINES, INC.**
155 Panay Avenue, South Triangle Homes, 1103 Quezon City, Philippines
Telephone : (63)2-9201071
- Taiwan : **SHIN TAIWAN AGRICULTURAL MACHINERY CO., LTD.**
16, Fengping 2nd Rd, Taliao Shiang Kaohsiung 83107, Taiwan R.O.C.
Telephone : (886)7-702-2333
- Indonesia : **P.T. KUBOTA INDONESIA**
JALAN. Setyabudi 279, Semarang, Indonesia
Telephone : (62)-24-7472849
- Thailand : **SIAM KUBOTA CORPORATION CO., LTD.**
101/19-24 Moo 20, Navanakorn Industrial Estate, Tambon Khlongnueng, Amphur Khlongluang,
Pathumthani 12120, THAILAND
Telephone : (66)2-909-0300
- Japan : **KUBOTA Corporation**
Farm & Industrial Machinery International Operations Headquarters
2-47, Shikitsuhigashi 1-chome, Naniwa-ku, Osaka, Japan 556-8601

English (Australia)
Code No. RG158-8193-1