

CORMIDI

MINIDUMPER

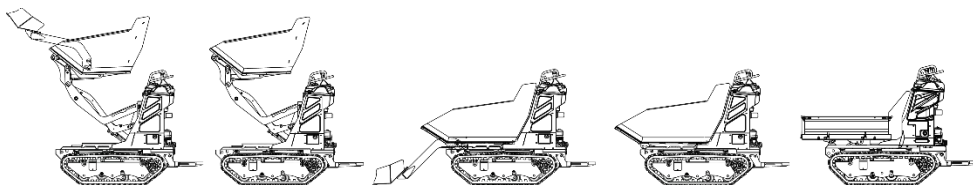

MUM.055.A.01.01

C55 SERIES

EN

55 series

Minitransporter

USER AND MAINTENANCE MANUAL

This manual must always be available so that the operator can immediately consult it and it must be kept for the entire life of the machine.

© 2010 - The reproduction and/or dissemination in whole or in part of this document in any form without the written permission of the manufacturer is prohibited.

Preparation of the texts, illustrations and layout was performed by "Cormidi s.r.l.". The information and technical data were provided, checked and validated by the Cormidi Technical Department. The illustrations and technical data contained in the manual are not binding: **The manufacturer reserves the right to make any changes to the product without notice.**



Ed. 1

CORMIDI srl

Via Fonte, 342

84069 Roccadaspide (SA)

☎ 0828 943689 Fax 0828 943963

💻 www.cormidi.com info@cormidi.com

INTRODUCTION

Dear Customer,

Thank you for purchasing a CORMIDI Minitransporter. This product was designed and built to last over time and to be used in complete safety.

It is however essential to carefully read this manual that describes the procedures for optimum use of the machine. Improper use can cause damage to the machine and result in injury and/or harm to health.

*Therefore, ensure this manual is always available so that it can be consulted at any time before, during and after use of the machine. In the case of resale, do not forget to hand it over, together with the minitransporter, to the new purchaser as it contains the **EC certificate of conformity**.*

Remember that the illustrations contained in the manual mainly refer to the basic model and that our models are regularly improved and perfected in order to allow our customers to gain maximum benefit from technological innovation. The characteristics and information contained in this manual may therefore have undergone recent changes. As such, we would ask you to contact us in case of any difficulties.

It any case it is recalled that for additional information you can always use your reseller/dealer or you can contact us directly by phoning us or sending us an e-mail at the address info@cormidi.com. If in doubt, it is preferable to enquire rather than proceeding on your own initiative.

We provide you with the letter of the manual and hope you enjoy using the machine. Cordial greetings.

The Staff of CORMIDI Srl

1. GENERAL INFORMATION

1.1. Warranty

Your machine is guaranteed for 12 months from the date of delivery and includes replacement of those parts that may, in the opinion of our Technical Department, be affected by construction defects.

The parts not made by the manufacturer, elements working in the soil and failures caused by incompetence or neglect, as well as consumables are excluded from the warranty.

The engine, instead, is covered by the engine manufacturer's warranty, according to the conditions and terms envisaged by it.

The warranty is immediately voided if the machine is employed for uses or purposes other than those recommended by the manufacturer, for damage caused by the application of accessories that are not authorised or for repairs carried out with unsuitable spare parts.

When the machine is shipped, it is accompanied by a Warranty Certificate that details the rules that regulate the performance of warranty service. We highly recommend that you read the **warranty form** to be fully aware of the rights and possible liabilities. Complete the form together with your dealer ensuring it is filled in correctly as the date, text content and other formalities required (dispatch under the relevant conditions, etc.) represent the legal basis of the right to the warranty on the vehicle.

Purpose of the Manual

This manual has been prepared by the manufacturer and is an integral part of the machine. It was drawn up in the Italian language, the original language of the manufacturer, and in accordance with section 1.7.4 of Directive 2006/42/EC.

The information it contains is intended for the skilled operator with specific competence in the field of use. The manual defines the purpose for which the machine was designed and built.

In order to avoid incorrect manoeuvres with the risk of accidents, it is important to read this manual, in particular upon initial use, in order to become familiar with the main controls and functions.

Constant observance of the information ensures the safety of persons, economy of operation and a longer duration of operation of the machine.

To give more prominence to the passages of text that must not be ignored, these are highlighted in bold and are preceded by the symbols illustrated and defined below.



READ CAREFULLY: an invitation to carefully and thoroughly read the manual before performing the operations described.



DANGER: it indicates an imminent situation of danger that can cause serious injury or death if the instructions are not followed.
Dangerous situations are highlighted on the machine with a

sticker characterised by a *red band associated with white text*

WARNING: it indicates a potentially hazardous situation which can cause serious injury or death if the instructions are not followed.



On the machine the warnings are highlighted with a sticker characterised by an *orange band associated with black text*.

CAUTION: it indicates a potentially hazardous situation which can cause injury or damage to the machine in case the instructions are not followed.



On the machine the situations in which it is necessary to exert prudence are highlighted with a sticker characterised by a *yellow band associated with black text*.



PROHIBITION: prohibitions which must be observed by all persons who interact directly and/or indirectly with the machine in order to limit the risks.

1.2. MACHINE DESCRIPTION

The C55 series Minitransporters are compact self-tipping tracked machines equipped with a container, designed and built exclusively for the transportation of inert material.

To meet the various market requirements, the machine can be equipped with motors of similar power to each other, but of different makes and characteristics.



READ CAREFULLY: identify with precision the type of engine mounted on your machine and refer to the annexed manual for information on it.

1.3. SAFETY INFORMATION



READ CAREFULLY: essential information is contained for your safety and for the safety of co-workers!

In building this machine, all measures were implemented to make your work safer. Prudence is in any case essential: there is no better rule to prevent accidents.



WARNING: The machine must always be operated by a competent and well-trained operator.

- ☞ Read the information carefully before installing the machine or carrying out maintenance and/or repairs.
- ☞ A few minutes spent reading this manual will save you time and effort later.
- ☞ Carefully read the warnings and information on the labels applied to the machine and immediately replace any that are lost or illegible. **Comply with all the rules contained therein .**

- ☞ The machine was built exclusively for the transportation of inert material. Any other type of use is prohibited.



PROHIBITION: It is absolutely forbidden to use this machine for the transportation of persons and/or animals.



PROHIBITION: It is absolutely forbidden to use this machine to tow other machines, vehicles and/or devices, even temporarily or in situations of emergency.

- ☞ The machine is a work instrument; always observe all national laws and regulations, mainly those relating to safety in the workplace.



OBLIGATION: always diligently wear clothing and, in particular, footwear of the type suitable for the work. Always use the hearing protection devices.



WARNING: Never wear loose or baggy clothing (scarves and ties) that could easily become entangled in moving parts.

- ☞ It is always advisable to have a First Aid kit to hand.
- ☞ Before starting the engine, always make sure that there are no persons, animals or property in the range of action that could hinder the work.



HAZARD: Never run the engine in closed rooms as the exhaust gases are lethal.



OBLIGATION: Dispose of mineral oils and harmful products in respect of the environment and current legislation.

- ☞ **Each operation** of cleaning, adjustment and/or maintenance should be performed in appropriate environmental conditions and with adequate brightness and **always with the engine off.**



HAZARD: Never refuel the vehicle with the engine running or hot, near a flame or while smoking. Always keep the machine clean from lubricant and/or combustible residues.

- ☞ Pay particular attention not to come into contact with overheated parts of the engine.



PROHIBITION: it is absolutely forbidden to remove the safety devices with which the machine is equipped.

- ☞ Avoid using the machine in physical conditions that are not suitable or when you are very tired. In such case it is preferable to halt the work.



HAZARD: During the work always make sure that the soil has the correct consistency and avoid working on the crest of embankments or ravines, or on land that is excessively steep or rough.

- ☞ When storing the machine, take all precautions so that it cannot be moved or started by incompetent or incapable persons.



CAUTION: Never leave the machine unattended when it is running, even temporarily: when you leave, turn off the engine and apply the parking brake!



HAZARD: Never allow children to play with the machine, even when it is off!

1.4. IDENTIFICATION OF MACHINE MANUFACTURER

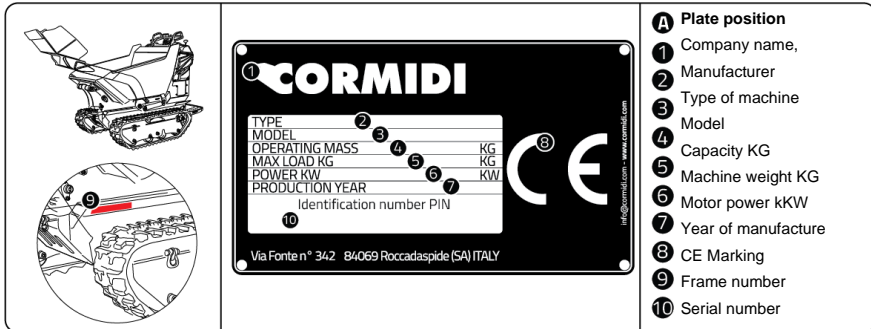

The identification data of the manufacturer and of the machine are shown on the aluminium summary plate attached to the dashboard of the machine, while the chassis number is stamped on the left rear strut (*see fig. 1*).

fig. 1 – Identification plate

1.5. SAFETY DEVICES



PROHIBITION: it is absolutely forbidden to use the machine with the safety devices and guards removed, locked or in any case placed in a condition of non-functionality.



WARNING: Before starting work, check the functionality of the safety devices and have the parts that are worn and/or broken immediately replaced.

1.5.1. LOCKING THE CONTAINER

The machine is equipped with a device that is used to lock the container in the raised position and prevents it from accidentally descending.

Before carrying out repairs and/or maintenance with the container raised, always lock the piston following the procedure (*see fig. 2*):

- Lift the container;
- Turn off the engine;
- Remove the safety device “2”, fixed on the frame right side member, by unscrewing the handwheel;
- Insert the slots of the bar close to the piston of the hydraulic jack;
- Turn the bar, positioning it parallel to the piston;
- Slowly lower the container **with the engine off** until engagement of the device.

1.5.2. LOCKING LIFTING (“Hi-Tip”) OF THE CONTAINER AND SELF-LOADER

The container lifting device, for high unloading (“Hi-Tip”), can be locked in the raised position to prevent accidental movement.

Before carrying out repairs and/or maintenance with the Hi-Tip raised, always lock the piston following the procedure.

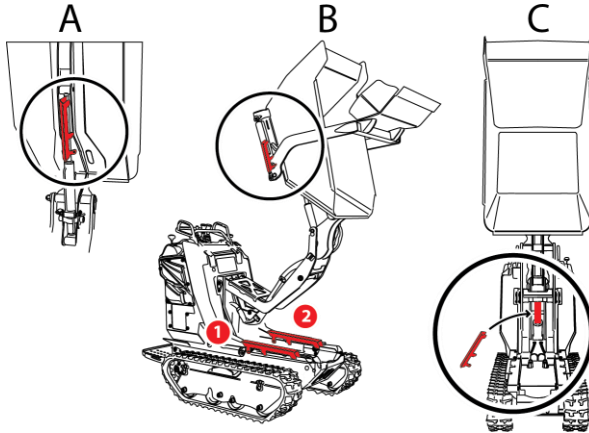

fig. 2 – Safety devices

- Lift the Hi-Tip mechanism, the arm and tilt the container
- Turn off the engine;
- Remove the safety device "1", fixed on the frame side member by unscrewing the black handwheel;
- Insert the slots of the bar close to the piston of the hydraulic jack C
- Turn the bar, positioning it parallel to the piston;
- Slowly lower the group **with the engine off** until engagement of the device.

The same procedure also applies to stopping the container and the arm.

At the end of the intervention, remove the device and place it back into its housing on the frame.

1.5.3. LOCKING THE PEDAL

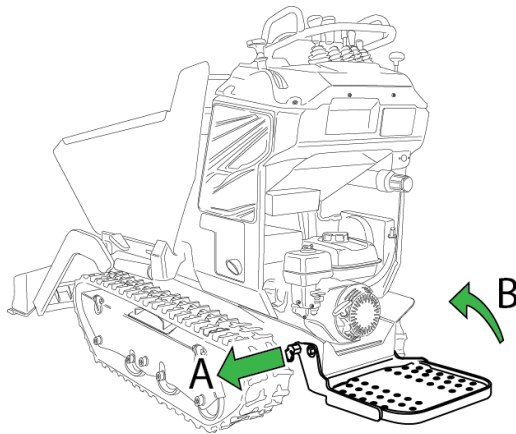

The driving platform must always be locked in the open position, while working, as in the image shown above; to prevent accidental movement, use the device on the left side of the platform, which consists of a spring-loaded safety pin "C" (see fig. 2).

- ☞ **To lower the platform:** pull the ring of the spring-loaded pin "A" outwards and lower the platform, releasing the ring. With lowering of the platform it will automatically be locked in the lowered position;
- ☞ **To raise the platform:** pull the ring of the spring pin "A" outwards and lift the platform releasing the ring. With raising of the platform it will automatically be locked in the lifted position;



ATTENTION: always use the driving platform in the open position while working to prevent accidents. Close the platform only after use.

1.6. ACCESSORIES PROVIDED



READ CAREFULLY the instructions and methods of use of any accessories installed on your machine.
Always refer to the manual that was provided with them.

The machine is equipped with tools for normal maintenance operations.

1.7. SAFETY PLATES



READ CAREFULLY: During the design phase, the greatest possible effort was made to prevent any accidents, however where it was not technically possible, specific pictograms were used to highlight any potential and imminent risks. Special stickers were therefore created with signals and a description associated to the pictograms to place greater emphasis on the possible danger, according to the indications of the standard UNI 9244-95 (E).



PROHIBITION: it is absolutely forbidden to remove the safety stickers and plates with which the machine is equipped: immediately replace any that are deteriorated and/or illegible.

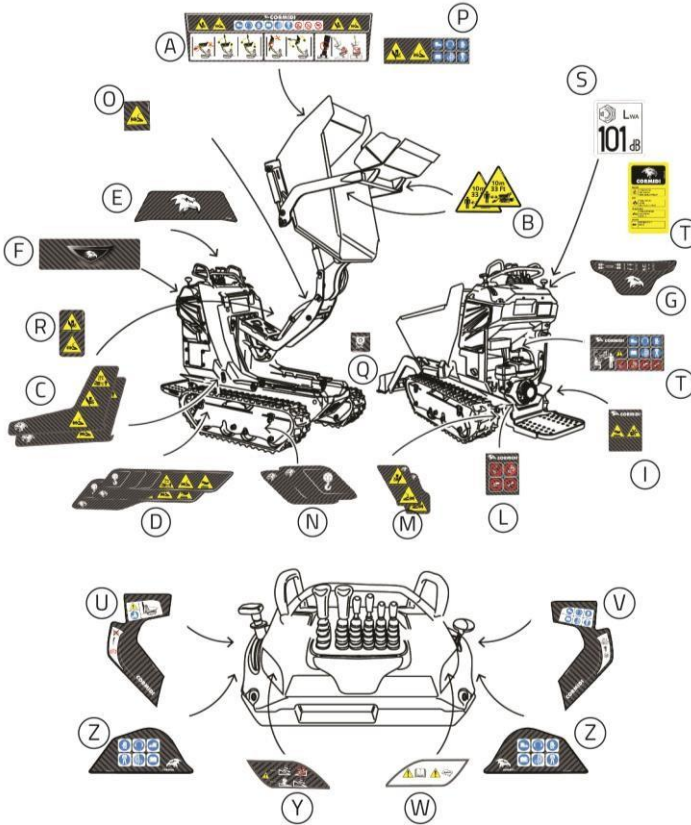

fig. 3 – Position of the safety plates

1.7.6. "H" "L" "P" "U" "V" "Z" PRUDENCE PROCEDURES

This sticker that calls for caution reminds of the need to take all the safety precautions, especially regarding the use of personal protection equipment. The meaning of the pictograms is as follows:



- Read the manual before starting the machine the first time, whenever the operator changes and in all cases where there is a uncertainty about its operation;
- Wear hearing protection headphones or other prescribed devices;
- Wear protective gloves of the type prescribed.
- Wear safety footwear of the type prescribed.

1.7.7. "Y" MAXIMUM SLOPES

Always avoid working on terrains with transverse slopes greater than 10° and longitudinal slopes greater than 20° to avoid the possibility of overturning with possible serious consequences for the operator's safety. In any case, but mainly in the case of slopes, it is important that the ground is solid and stable.

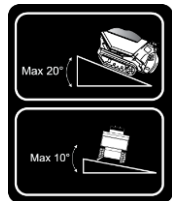

1.7.8. HOW TO TACKLES SLOPES

Plate indicating how descents and climbs must be tackled to avoid serious consequences for the user and for the machine as there is a potential danger of tipping over.



1.7.9. "I" FAN AND OVERHEATING

Fan: Potential risk of coming into contact with fans and/or rotating systems that can cut the limbs; Do not touch the areas surrounding this pictogram.

Overheating: Hot and/or boiling parts that can cause irreversible damage and injuries. Do not touch the areas surrounding this pictogram.





1.7.10. LABEL D B

It indicates the noise level.

1.7.11. "T" INDICATIONS ON OILS

This plate contains all the information about the oils that can be used for the C55 series.



1.7.12. "W" READ THE USE AND MAINTENANCE MANUAL

It is reported on the dashboard of the machine that the use and maintenance manuals should be read.



PERMISSIBLE SLOPES

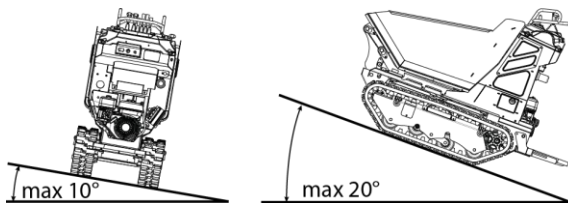

Fig. 13 – Maximum *recommended* slopes.

Figure 13 shows the maximum recommended values of the transverse and longitudinal slope of the terrain with which it is possible to work.

These conditions must never be exceeded to avoid the risk of overturning.



HAZARD: Always avoid working on terrains with slopes greater than those prescribed to avoid the possibility of overturning with possible serious consequences for the operator's safety.

In any case, but mainly in the case of slopes, it is important that the ground is solid and stable.

1.8. DIMENSIONS

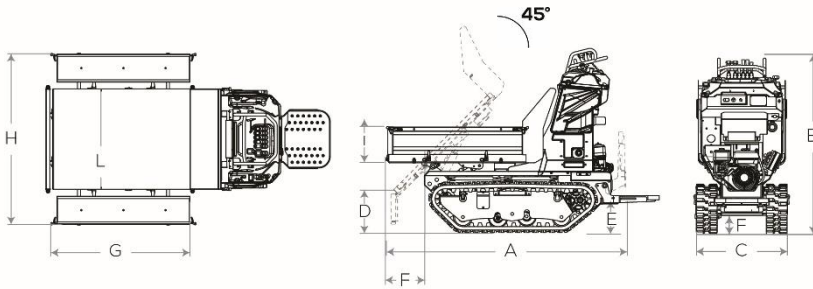

RIA

	mm	in
A	1751	68.9
B	1388	54.6
C	716	28.2
D	315	12.4
E	200	7.9
F	140	5.5
G	980	38.6
H	1213	47.8
I	261	10.3
L	716	28.2
	m ³	
Colmo SAE	0.21	
Colmo CECE	0.18	
Raso	0.13	

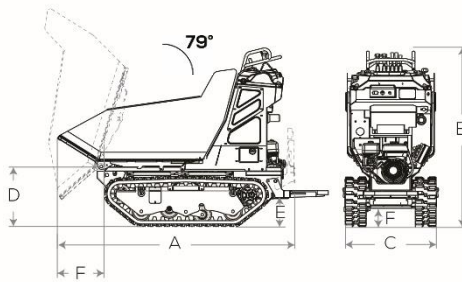

RI

	mm	in
A	1760	69.3
B	1388	54.6
C	716	28.2
D	480	18.9
E	200	7.9
F	140	5.5
	m ³	
Colmo SAE	0.28	
Colmo CECE	0.26	
Raso	0.22	
Acqua	0.09	

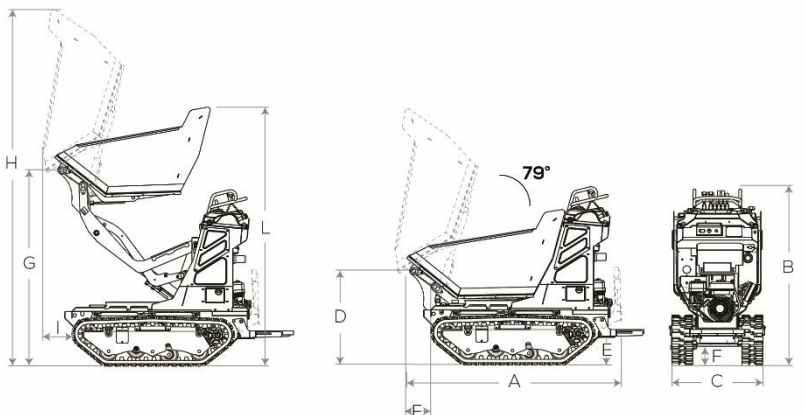

HI

	mm	in
A	1670	65.8
B	1388	54.6
C	716	28.2
D	730	28.7
E	200	7.9
F	140	5.5
G	1540	60.6
H	2800	110.2
I	214	8.4
L	2033	80.0
	m ³	
Colmo SAE	0.30	
Colmo CECE	0.28	
Raso	0.23	
Acqua	0.15	

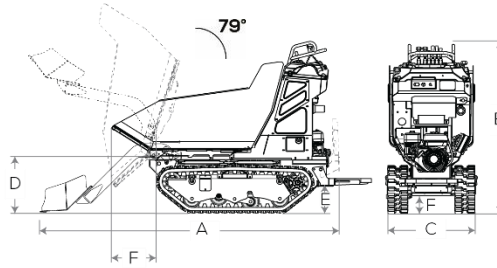

AC

	mm	in
A	2300	90.6
B	1388	54.6
C	756	29.8
D	480	18.9
E	200	7.9
F	140	5.5

	m ³
Colmo SAE	0.28
Colmo CECE	0.26
Raso	0.22
Acqua	0.09

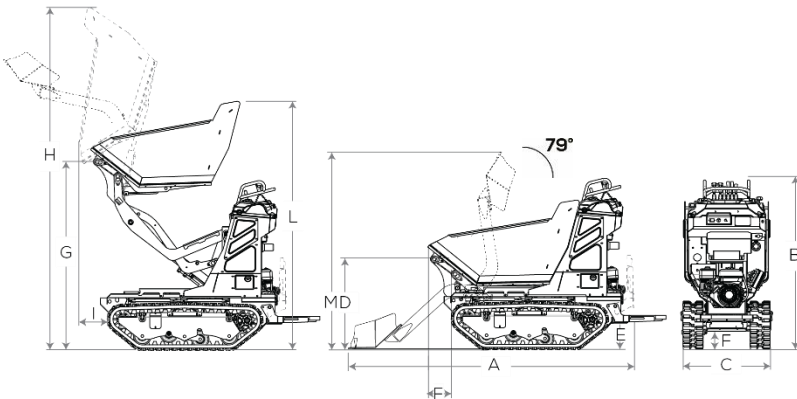

HIAC

	mm	in
A	2300	90.6
B	1388	54.6
C	756	29.8
D	730	28.7
E	200	7.9
F	140	5.5
G	1540	60.6
H	2800	110.2
I	214	8.4
L	2033	80.0
M	1528	60.2

	m ³
Colmo SAE	0.30
Colmo CECE	0.28
Raso	0.23
Acqua	0.15

1.9. TECHNICAL DATA

Model	Dumper	Self-loading	Hi-Tip	Self-loading Hi-Tip
Type	C55 RI	C55 AC	C55 HI	C55 HIAC
Weight [kg]	458	501	547	623
Engine	Petrol	Petrol	Petrol	Petrol
Power [kW] - (hp)	4.3 (5.8)	4.3 (5.8)	4.3 (5.8)	4.3 (5.8)
Max speed [km/h] - (m/s)	3.6 (1.2)			
Capacity [kg]	550			
Start-up	PULL			
Accelerator	With lever manual control			
Transmission	Hydrostatic			
Parking Brake	Mechanical			

	C55
Measured sound power level	LWA = 98 dB
Guaranteed sound power level	LWA = 101 dB
Sound pressure level measured at operator ear	LpA= 79 dB
Vibration level on the arm	aw (m/s²) 2.5 m/s²
Vibration level on the machine body	aw (m/s²) 1 m/s²

2. COMMANDS

2.1. ACCELERATOR

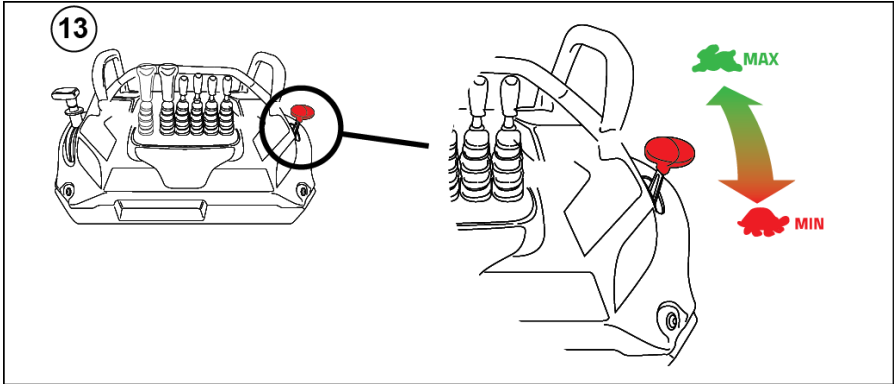

2.2. PARKING BRAKE

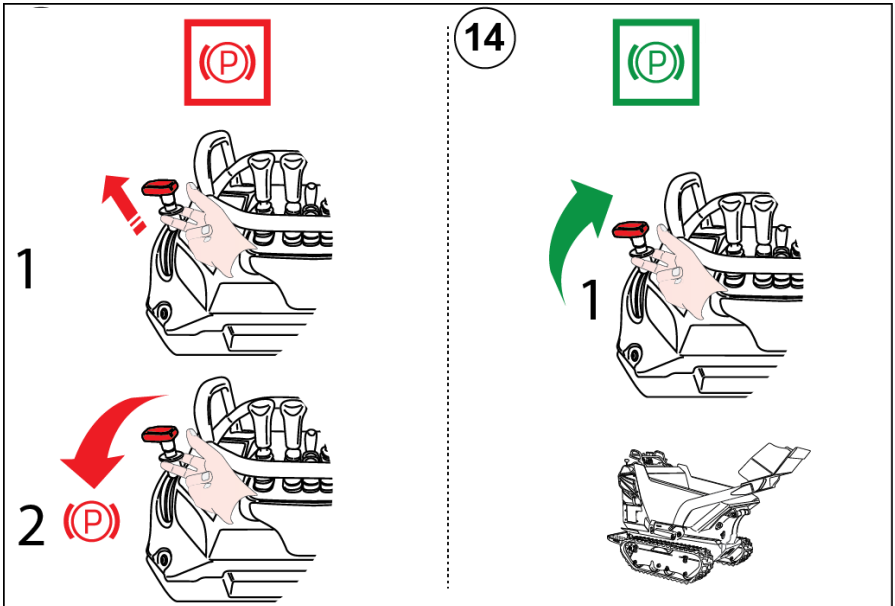

2.3. TURN TO THE RIGHT (MOVE THE LEFT TRACK)

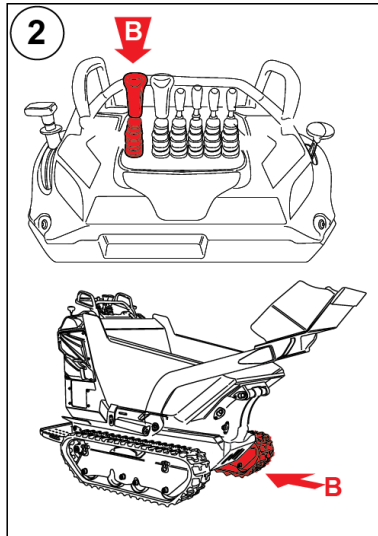
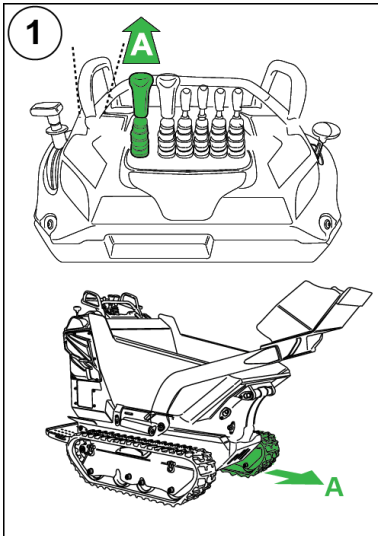

2.4. TURN TO THE LEFT (MOVE THE RIGHT TRACK)

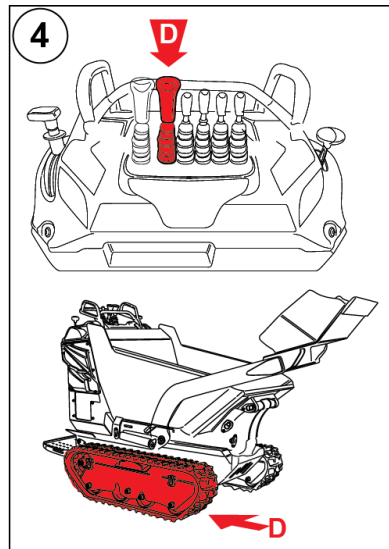
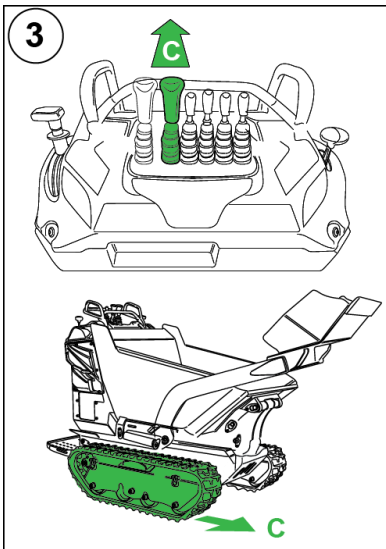

2.5. MOVE THE MACHINE FORWARD AND BACK

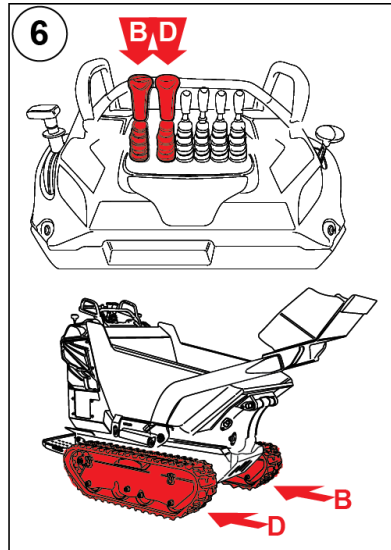
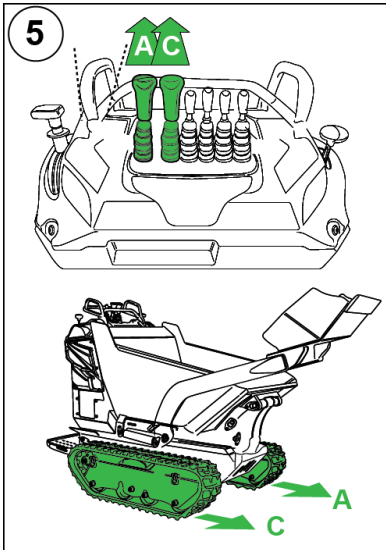

2.6. DOUBLE SPEED (ALL VERSIONS)

Ve

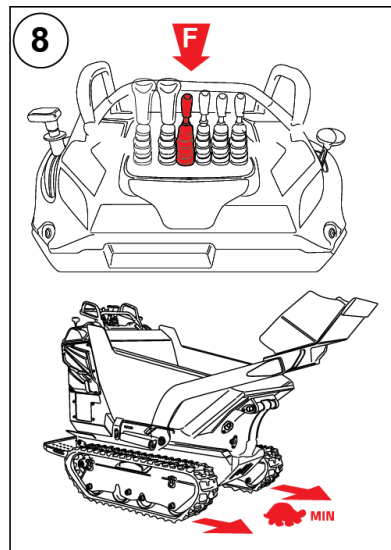
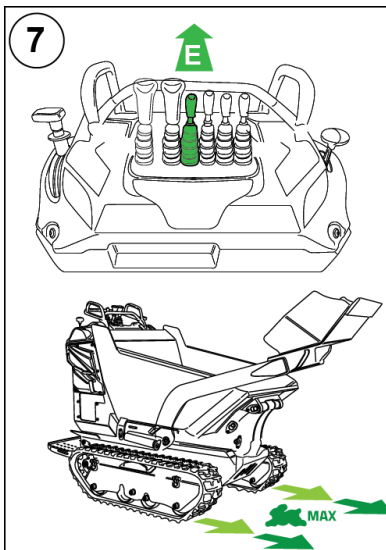

1.1. CONTAINER LEVER (VERSIONS RI-RIA)

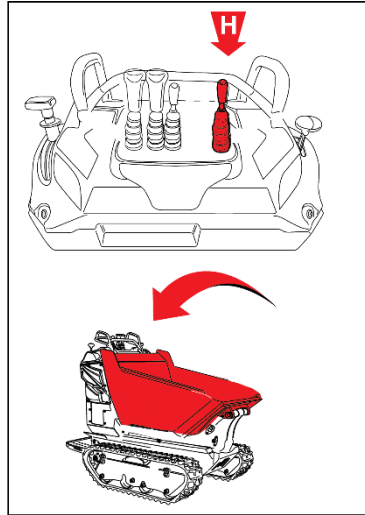
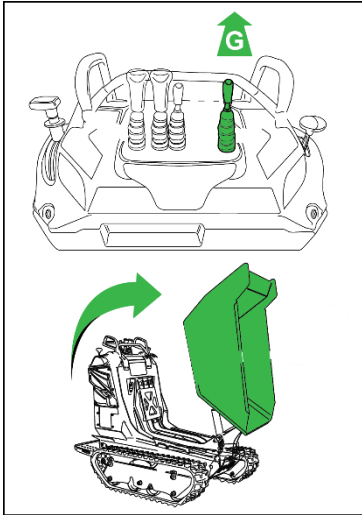

1.2. CONTAINER LEVER (VERSIONS AC)

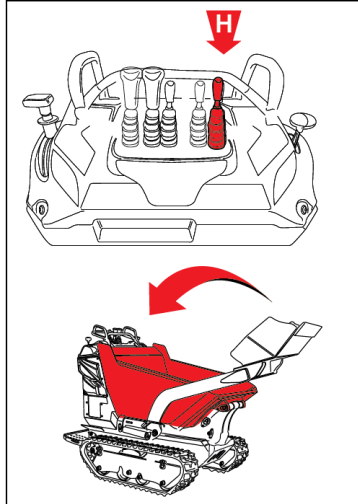
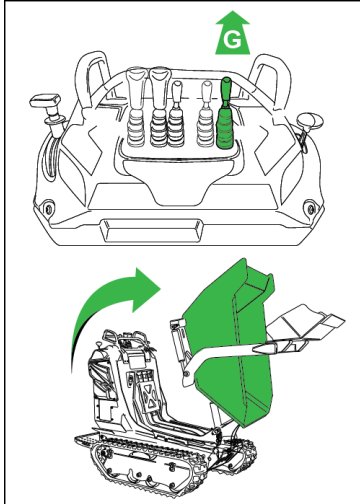

1.3. CONTAINER LEVER (VERSIONS HI)

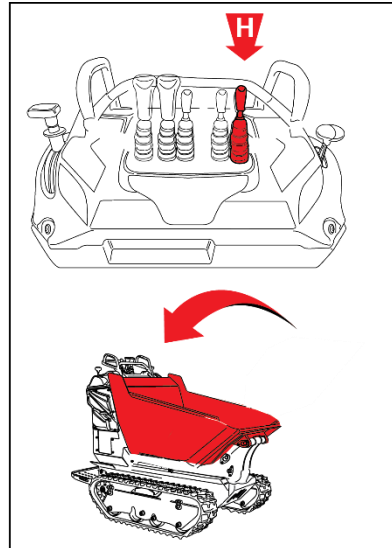
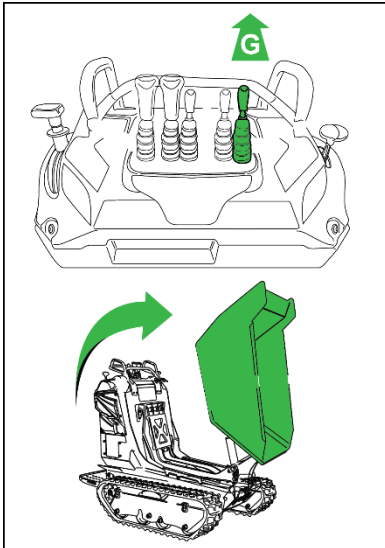

1.4. CONTAINER LEVER (VERSIONS HIAC)

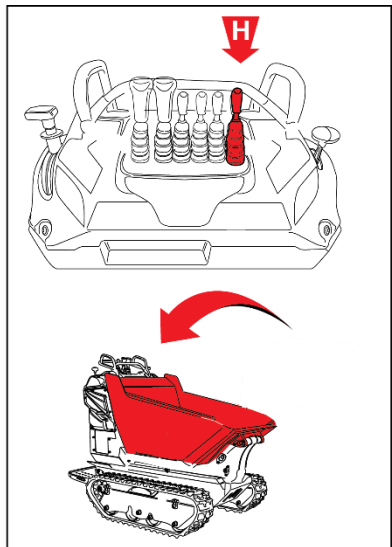
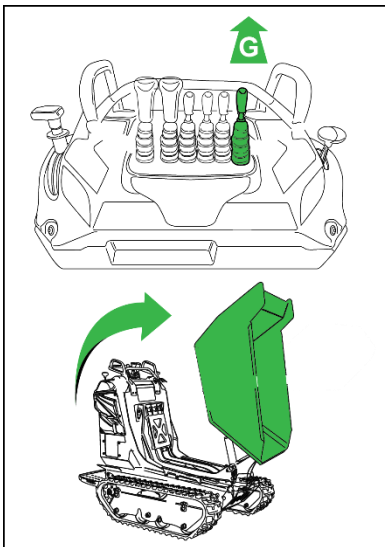

1.5. HIGH UNLOAD LEVER (VERSION HI)

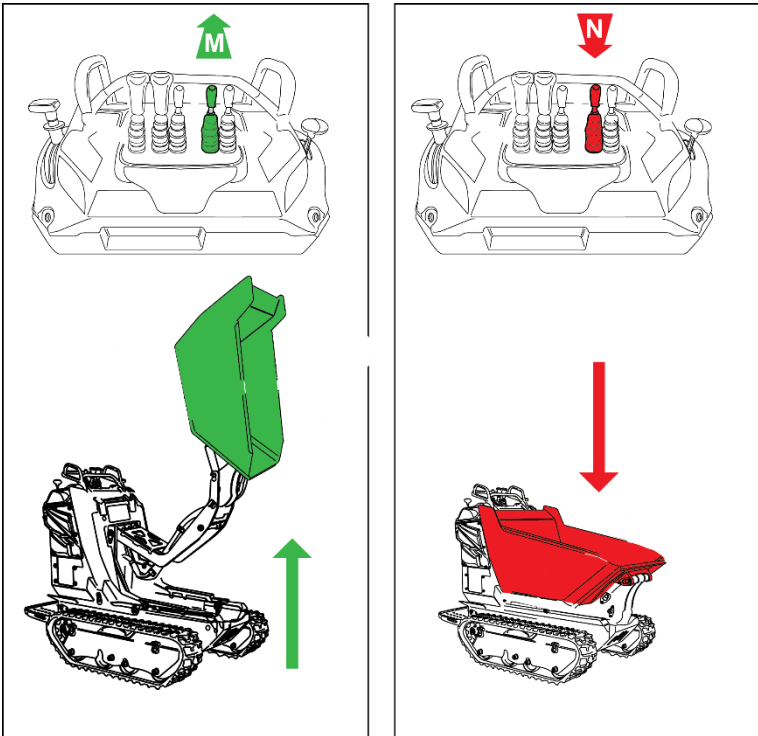

1.6. HIGH UNLOAD LEVER (VERSION HIAC)

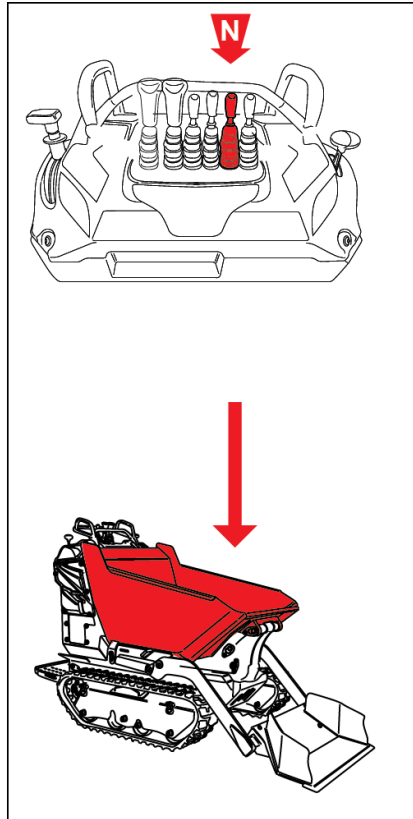
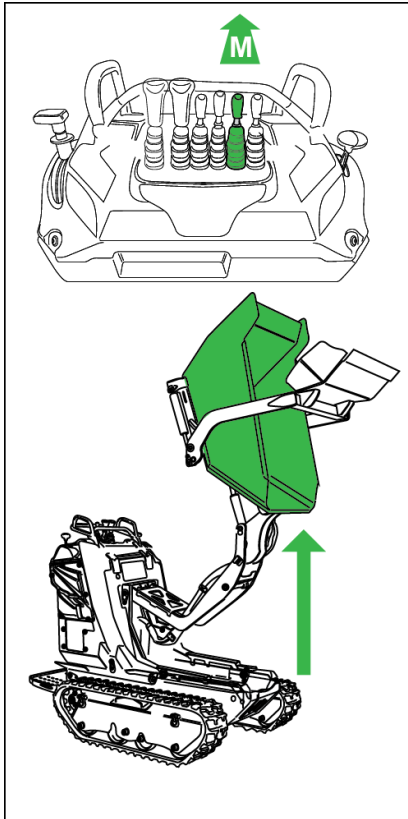

1.7. SELF-LOADING LEVER (VERSION AC)

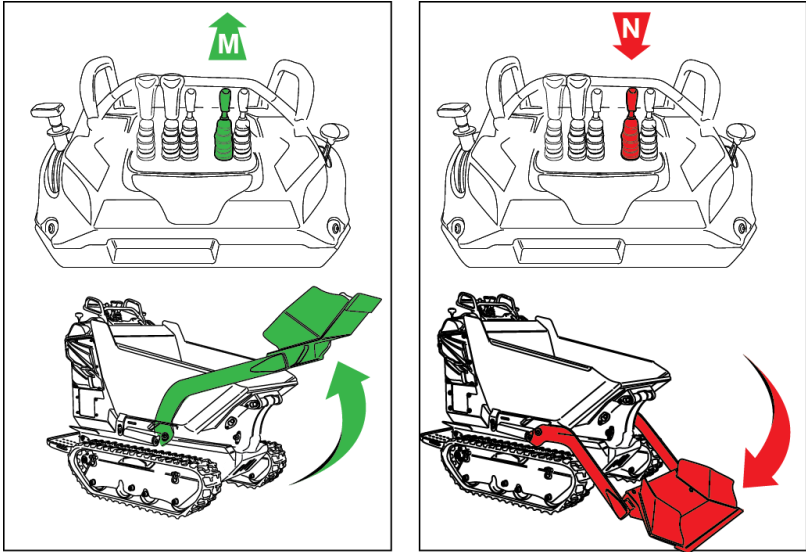

1.8. SELF-LOADING LEVER (VERSION HIAC)

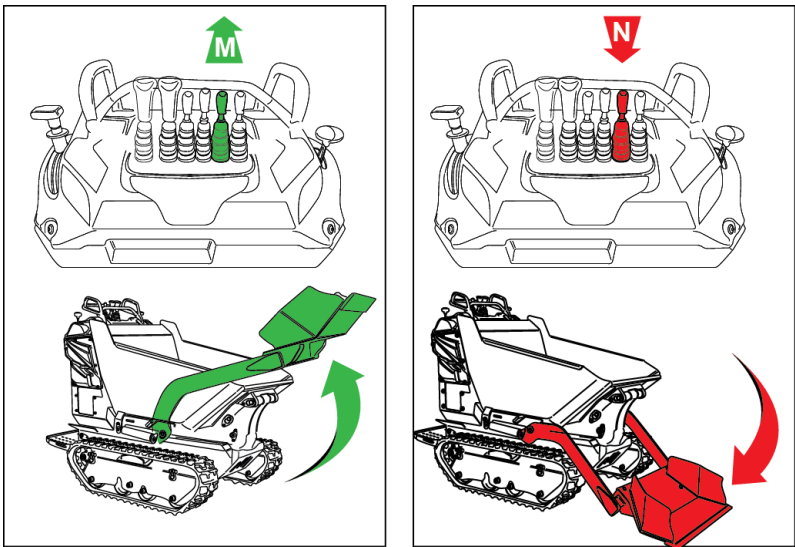

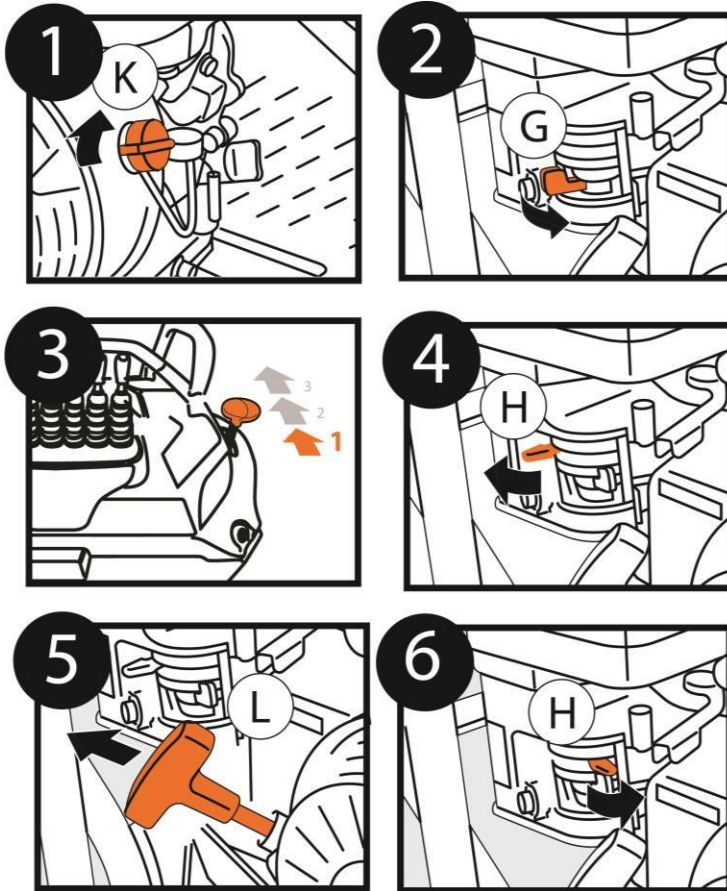

2.1. TURNING ON THE ENGINE

- 1 Turn the knob **K** clockwise
- 2 Move the orange lever **G** to the right
- 3 Move the accelerator forward, to the middle of the stroke.
- 4 Move the black/orange lever **H** to the left
- 5 Pull **L** towards you vigorously, release as soon as it reaches the end of the stroke
- 6 Reclose towards the right **H**

2. USER REGULATIONS

2.1. FIRST USE



READ CAREFULLY: before using the machine it is necessary to carefully read all the instructions in this manual and in the use and maintenance manual of the engine installed on your machine, which must remain constantly attached.

The use and maintenance manual, together with that of the machine engine, must always be readily available, and must be kept in the dedicated cylindrical container on the machine (see fig. 34 to the side).

The machine is normally delivered completely assembled and ready to be used, with the fuel tank empty.

Refuel, open the fuel tap and perform the starting procedure described in the specific paragraph.

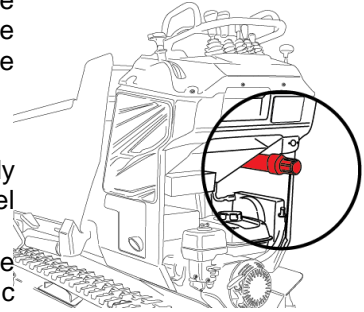

2.2. RUNNING-IN PERIOD

The technology used for the construction of your machine does not require running-in periods. However during the first period of use some precautions must be taken:

- ☞ During the first 50 hours avoid using the engine over 70% of the total load.



READ CAREFULLY the use and maintenance manual of the engine installed on your machine and follow the instructions prescribed for running-in of the same.

- ☞ After the first 20 hours of operation, check the hydraulic oil level in the tanks.
- ☞ During the initial period of use, the tracks undergo settling, so it is necessary, after the first 50 hours of operation, to adjust the tension of the tracks.

2.3. STARTING THE ENGINE

Whenever you are about to start the engine, always strictly follow what is indicated below:

- Always start up outdoors and make sure there are no other persons near the machine and/or other obstacles.
- Check that there is fuel in the tank and, if necessary, add more.
- Always engage the parking brake



WARNING: Before starting the engine, always apply the parking brake to avoid any movement of the machine which could have consequences for the operator's safety.

- Follow the specific procedure provided by the engine manufacturer and reported in the annexed instructions.

With the engine warm, avoid inserting the starter.

2.4. REFUELLING



HAZARD: Refuelling must always be performed with the engine off! Do not smoke while refuelling or handling fuels to avoid the risk of fire!

Refuelling and/or the transfer of fuel must always be carried out outside, away from fire or heat sources. Always check that the type of fuel is the one specified, specific to the engine of your machine.

- Position the machine on a clean surface.
- Unscrew the cap slowly.
- Pour the fuel slowly into the tank.
- Screw the cap back on tightly.
- Dry off any spilled fuel immediately.



WARNING – Only start the engine after making sure that there are no traces of mixture that have accidentally spilled!



WARNING – Fuel must always be stored in compliance with the specific regulations, in suitable places, away from heat sources and in suitable, well cleaned and sealed containers!



OBLIGATION: Avoid dispersing fuels and/or containers in the environment, but dispose of them in respect of the environment and the current legislation.

2.5. STARTING THE MACHINE



HAZARD: Always avoid loading the machine beyond the limits set: during manoeuvres, overloading can result in unexpected changes in configuration and cause overturning with serious consequences for the safety of persons.



WARNING: As far as possible, try to avoid driving on stony, gravelly ground, on rails and logs as they could damage the tracks, reducing their service life. Also avoid passing over materials that could damage the tracks, such as pointed bodies, iron rods, etc.

which could become stuck in the tracks and cause them to break.

Upon start-up, adjust the number of engine revolutions to the desired level by operating the accelerator lever, according to the power required (when the machine is loaded, it will be necessary to bring the lever to more than half the stroke between the minimum and maximum).

In certain conditions, especially with the machine loaded or when moving uphill, a loss of drive torque may occur due to an overload of the engine, which can also result in its stopping. In this case, slowly release the drive levers, adjusting the speed to a level that no longer causes the engine to overload.

As the machine is equipped with a hydrostatic transmission, **the engine revolutions do not need to be set to maximum** for translation. Allowing the engine to run at maximum rpm does not improve the functionality of the machine but **undoubtedly (and unnecessarily) increases fuel consumption**: it is therefore advisable to increase the engine rpm only where it is strictly necessary (to move at maximum speed, to tackle considerable climbs at full load, etc.).

3.5.1. DRIVING POSITION

When driving the machine and during work, always use the driving platform in the lowered position (*see fig. 35*), to prevent accidents. Close the platform only after use.

To use the platform, position it correctly (*see fig. 2*):

- Pulling the spring pin on the right side of the platform, it unlocks;
- Rotate the platform to the horizontal position;
- Once in position it will be automatically locked by the spring pin.



HAZARD: Never drive with the platform unlocked: always check that the platform is locked and that the safety pin is correctly positioned.



WARNING: When you open or close the platform, pay attention to your hands: avoid suffering cuts or crushing.

While driving, always hold the grab handle firmly with one hand and simultaneously act on both drive levers with the other hand.

Never let go of the handle to operate the levers with both hands.

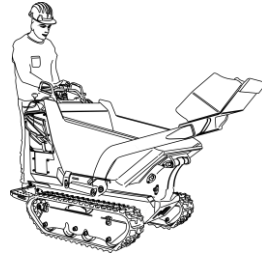

Fig. 35 – Driving position



HAZARD: While the machine is running, the operator must always assume and maintain the prescribed driving position.

Never rush during work, but proceed at a speed appropriate to your pace, in order to always maintain a safe position of control of the commands.

3.5.2. MOVING FORWARDS

To allow the machine to move forward it is necessary to act simultaneously on both drive levers, pushing them forward.

Avoid tackling descents while driving forward, but refer to the paragraph: “Moving on slopes”.

3.5.3. REVERSING

To allow the machine to move back, it is necessary to act on both drive levers by pulling them back simultaneously.

Avoid moving uphill when reversing, especially with the machine loaded, but follow the procedure described in the paragraph “Moving on slopes”.



HAZARD: When reversing, always check that there are no obstacles and/or persons nearby.

3.5.4. MOVING ON SLOPES



HAZARD: Absolutely avoid working on terrains with transverse slopes greater than 10° and with longitudinal slopes greater than 20° to avoid the possibility of overturning with serious consequences for the operator's safety.

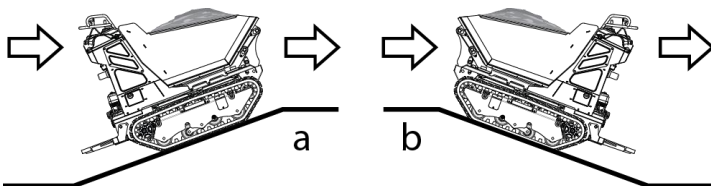

fig. 36 – a) uphill travel; b) downhill travel

When tackling slopes, especially with the machine loaded, the following particular driving technique must be observed (*see fig. 36*):

- ☞ Always tackle ascents in forward gear;
- ☞ Always tackle descents in reverse.

The machine is equipped with an automatic anti-cavitation speed control system.

3.5.5. STOPPING TRAVEL

Stopping of travel during movements takes place by releasing the track advance levers at the same time.

3.5.6. TAKING BENDS

To allow the machine to take bends it is necessary to release the lever from the side towards which you intend to bend:

- ☞ To turn to the right, release the right driving lever;
- ☞ To turn to the left, release the left driving lever.

Steering is determined by slowing down the speed of one track relative to the other. Consequently, the speed and degree of steering are proportional to the intensity of the release and to the pressure with which you act on each lever.

3.5.7. COUNTER-ROTATION



WARNING: Avoid performing counter-rotation, especially when the machine is loaded

It is also possible to rotate the machine on itself. At the same time it is advisable to avoid performing counter-rotation in order to avoid damaging the tracks and the undercarriage; therefore, as an alternative, without rotating around its axis, the rotation radius must be lengthened by letting the tracks slide on the ground much more gently, avoiding reversing travel with counter-rotation.

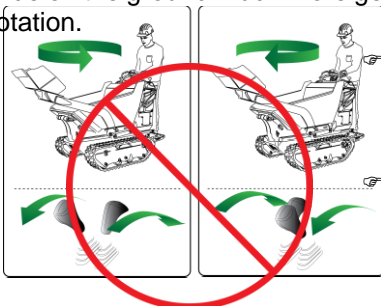

Clockwise counter-rotation (in the direction of the clock hands).

fig. 38 – Clockwise counter-rotation

Anti-clockwise counter-rotation (in the direction opposite to that of the clock hands).

fig. 39 – Anti-clockwise counter rotation

2.6. STOPPING AND PARKING



WARNING: if you move away and leave the machine unattended, always apply the parking brake and make sure that no unauthorised person can start or move it.

Before stopping the machine, preferably assume a position on a flat paved surface or, in any case, on flat, stable and compact ground.

- Using the accelerator lever, bring the engine to the minimum number of revolutions.
- Apply the parking brake.
- Turn off the engine.
- Close the petrol tap (on the engines equipped with it).

2.7. USING THE PARKING BRAKE

The machine has a safety device called the "**Parking brake**" which prevents the machine from moving even by operating the towing controls. This device is used to prevent accidental movement of the machine in the absence of the driver; it also functions as an emergency stop if the operator needs to instantaneously block the machine during work.



PROHIBITION: it is absolutely forbidden to use the parking brake while the machine is moving to stop the machine from running, except in an emergency.

Activation: Pull the lever towards you by first lifting the ring under the knob towards you with two fingers: **the brake is engaged**
Deactivation : Push the lever in the opposite position: **the brake is released.**

WARNING – If the lever offers considerable resistance when trying to release the brake, avoid forcing the mechanism as the wheel is blocked. Before releasing the brake, move the machine slightly forward or backward until the device is released.



Emergency brake: the parking brake also acts as a brake in emergency situations. To perform emergency braking, pull the lever slightly towards you, move it to the left, making it come out of the slot and release it: the brake will automatically engage.



DANGER: should it be necessary to use the emergency brake, consider that this involves instantaneous blocking of the traction mechanism which could cause loss of control of the machine.



WARNING: after the emergency brake has been activated, have the device checked for integrity and functionality: continuing to use the machine with the device inefficient could be dangerous for your safety and for that of others.

2.8. TRANSPORTING A LOAD



PROHIBITION: it is absolutely forbidden to exceed the capacity limits indicated in the table in para. 12.

3.8.1. CONSTRUCTION CONTAINER (DUMPER)

The standard machine is equipped with a "dumper" type container for the transportation of solid inert materials, mainly indicated for use in construction work.

2.9. UNLOADING MATERIAL

3.9.1. TIPPING THE CONTAINER



WARNING – Before unloading, make sure the ground is level, solid and compact. Perform the tipping manoeuvre slowly and evenly. Do not move the machine during tipping operations.

Your machine is equipped with a hydraulic device to tip the container to unload the material.

To perform the tipping manoeuvre:

- Place the machine on a flat surface or on ground that is firm and compact;
- If the machine is equipped with an agricultural container, remove the front side;
- Push the lever forward to cause the material to tip and unload;
- Pull the lever back until the container has returned to the driving position and then release the lever.



CAUTION: during unloading, if the container strikes an obstacle, avoid moving the machine forward: this could damage the container coupling seats!



PROHIBITION: it is absolutely forbidden to move if the container is not in the rest position.

3.9.2. USING THE SELF-LOADING ARM



WARNING – Before using the arm, make sure that the ground is level, solid and compact. Perform the tipping manoeuvre slowly and evenly.

Your machine is equipped with a hydraulic device that allows use of the bucket to load the material into the machine container.

To perform the self-loading manoeuvre:

- Position the machine on a flat surface or on ground that is firm and compact;
- Push the lever forward to lower the bucket and move forward until the bucket is full;
- Pull the lever back by raising the arm until the end of the stroke; the material

will slip away from the bucket and fall into the container;

- Repeat the operation several times to fill the container;



CAUTION: When using the arm, make sure that the latter does not accidentally collide with surrounding objects and check that there is nothing in the range of action of the arm.

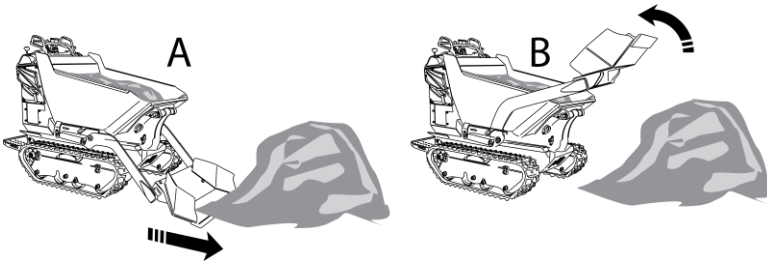

LIFTING THE CONTAINER (“Hi-Tip”)

Upon request, the machine can be set up with a hydraulic device to lift the container during unloading to allow unloading into containers or tanks with a high edge, called “Hi-Tip”.

The system is equipped with a safety valve which, even in the event of breakage of the hydraulic pipes, prevents accidental lowering of the unit.

To unload the material, act as normal on the container tipper lever (as indicated in the previous paragraph).

To unload, proceed as follows:

- Position the machine on a flat surface or on ground that is firm and compact;
- Raise the container to the desired height by pushing the lifting lever forward;
- Push the tipping lever of the container forward to allow the material to be unloaded.

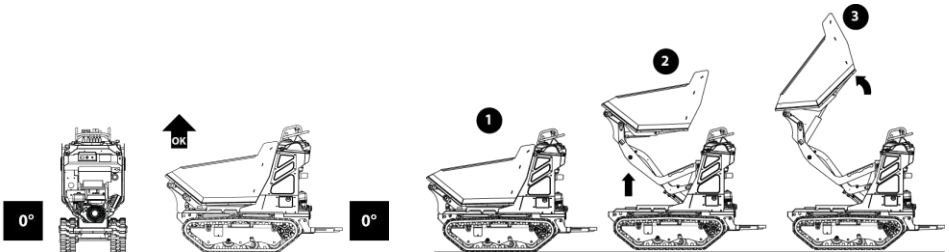

Fig. 40 - Position for high unload



HAZARD: Lift only on firm, compact and perfectly level ground

To return the container to the travel position, proceed as follows:

- First pull the tipping lever back and return the container to the horizontal position;
- Release the container control lever
- Pull the container lifting lever backwards until it reaches the driving position;
- Release the lifting lever.



HAZARD: Never lift the container without first stabilising the machine with the self-loading shovel.



DANGER: do not under any circumstances act on the lifting lever while driving as this could cause the machine to overturn.

2.10. TRANSPORTATION



WARNING: during transportation, always place the machine on a level surface to avoid the spilling of oil or other liquids.

If the machine is to be transported, proceed correctly in order to avoid danger to persons and/or damage to the machine. If the machine is equipped with it, **keep the bucket completely lowered during transportation**. Given the weight of the machine, it cannot be handled manually. As such, it is necessary to use suitable lifting equipment for loading onto transportation vehicle.

The machine is equipped with **4 lifting hooks** each with a capacity of 7,000N (approximately 700kg) for a **total of 28,000N (approximately 2,800kg)**.

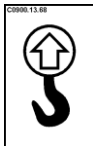

*Fig. 43
Lifting
point*

The position of each hook is indicated by a plate such as the one shown in fig. 43 (C0900.13.66).

To carry out the operation in complete safety, it is advisable to use 4 as the lifting device ropes with hooks, of the CE approved type; the front and rear ropes can be of equal length approximately 170cm; for lifting proceed as follows:

- Disconnect the battery by acting on the battery disconnection switch;
- Empty the fuel tank and close the tap;
- Fasten the lifting means only to the anchor points provided by the manufacturer (fig. 44);



WARNING: lift the machine by hooking it only by the eyebolts provided for the purpose: anchoring to other points can cause breakage with consequent falling of the machine and the possibility of serious damage to persons.

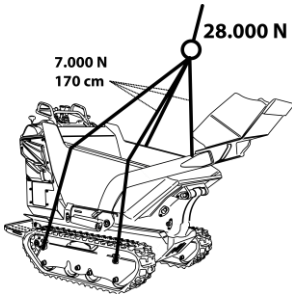

fig. 44 – Anchor points for lifting.

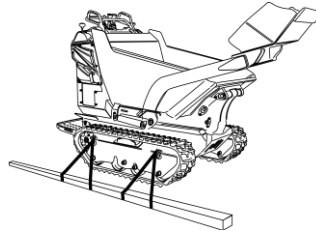

fig. 45 – Anchor points for transportation

- Fasten it firmly to the platform of the means of transport by means of sturdy CE approved tie rods, always connecting them to the points shown as in figure 45.
-

2.11. TOWING

The machine is equipped with tow hooks, located in the lower part of the undercarriage, both front and rear (see fig. 47); if it is necessary to tow the machine, be sure to **empty the container**.

Each anchor point for towing is highlighted by a plate bearing the symbol shown in fig. 46 and can support a traction force of approximately 10,000N (1,000kg).

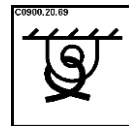

Fig. 46 - Towing point

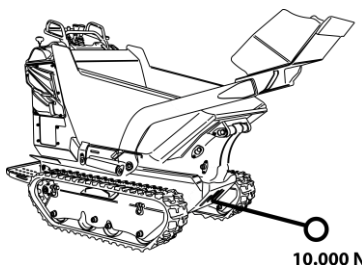

Fig. 47 – Anchor points for towing, front and rear

2.12. STORAGE

If the machine must remain inactive for several months, it is necessary to ensure correct storage so that it is perfectly in order when it is put back into operation.

Perform storage following all the indications:

- Perform all the necessary repairs.
- Disconnect the battery by acting on the battery disconnect device;
- Completely empty the fuel tank;
- Proceed with thorough cleaning, carefully removing all residues of mud and/or organic substances;
- Proceed with all the operations concerning the engine and described in the engine manual;
- Perform greasing at all the points provided in the specific chapter;
- Store the machine away from atmospheric agents, in stable conditions and on a flat floor.
- If the machine is equipped with a battery, disconnect the terminals and lubricate them with the appropriate grease;
- Periodically, every two months, recharge the battery;
- If the machine engine is equipped with a start key; take it out and keep it in a safe place.

Upon re-commissioning:

- Re-grease at all the points provided in the specific chapter;
- Proceed with any operations concerning the engine and described in the engine manual;
- Check the oil level and, if necessary, top it up.

3. MAINTENANCE



DANGER: always perform all maintenance operations with the engine off and the ignition key removed.

Good maintenance is necessary and is the secret to obtaining low operating costs and prolonging the life of your machine, always keeping it in full efficiency. In addition to the normal maintenance operations on the mechanical and hydraulic parts, it is good practice to periodically wash the machine and to perform thorough cleaning to remove all mud residues. After each wash it is necessary to grease all parts subject to friction, as specified in the paragraph "Greasing".

3.1. MAINTENANCE INTERVALS

To maintain the highest level of efficiency, maintenance must be carried out on a regular and scheduled basis. The following table shows the summary of maintenance operations to be performed periodically.

(i) Maintenance and adjustment table

<i>Work frequency</i>	<i>Description</i>	<i>Verificatio</i>	<i>Greasing</i>	<i>Cleaning</i>	<i>Adjustment</i>	<i>Replacemen</i>
Every 8 hours	Machine			✓		
	Driving lever			✓		
	Control lever			✓		
	Container		✓			
	Air filter (1)(2)	✓		✓		
	Hi-Tip lifter		✓			
	Track Rollers		✓			
	Engine oil(1)	✓				
Every 50 hours	Tracks				✓	
	Hydraulic Oil	✓				
	Air filter (1)(2)			✓		
	Engine oil (1st change)					✓
Every 100 hours	Parking brake				✓	
Every year or 300 hours	Hydraulic Oil					✓
	Services hydraulic oil filter					✓
	Traction hydraulic oil filter					✓
	Dry air filter (1) (2)					✓
	Engine oil(1)					✓
(1) Check the annexed engine manual						
(2) In dusty areas it is necessary to increase the frequency						

3.2. ENGINE



CAREFULLY READ the instructions and the mode of use of the engine shown in the specific manual annexed.

The machine that was delivered to you can be originally equipped with different engines for specific needs and/or markets.

Correct maintenance is the best way to keep your machine's engine running at full efficiency and to keep operating costs low. For engine maintenance, strictly follow the annexed manual that has been delivered to you.



OBLIGATION: When changing the oil in the engine, always use a dedicated suction device to remove the used oil. Always avoid dispersing oil and filters into the environment and dispose of them respecting the environment and the current legislation.

4.2.1. REFUELLING

-Loosen the chromed silver cap screwed on the tank

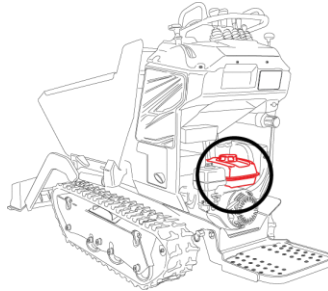

- insert a dedicated funnel and pour in petrol

4.2.2. ENGINE OIL LEVEL CHECK

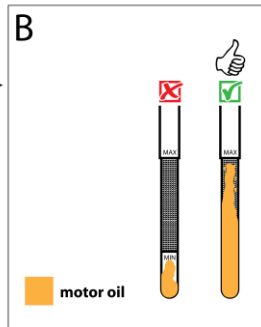
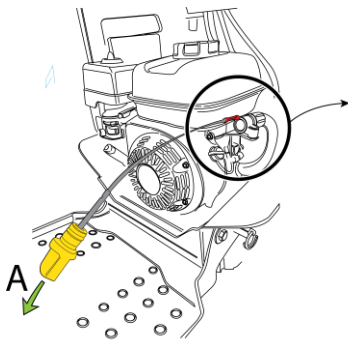

-A extract the oil stick

-B check that it is impregnated with oil up to: **Max**

4.2.3. AIR FILTER

Your machine is equipped with a special air filter with high filtering power.

The air filter requires periodic maintenance to ensure correct functioning of the machine. They are easily accessible.

To clean it just a few simple steps are required:

- Loosen the plastic screw 1
- Lift the plastic casing 2

- Pull the filter away and clean it, without damaging it, with an air gun connected to a compressor;

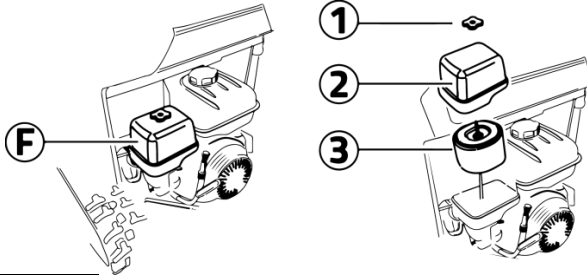

Every 8 hours remove the filter cartridge “3” from its housing and perform thorough cleaning by blowing with compressed air. **Every 300 hours or at least once a year**, it is necessary to replace the air filter cartridge, “3” following the same procedure used for cleaning.

3.3. HYDRAULIC CIRCUIT

4.3.1. HYDRAULIC OIL



OBLIGATION: Do not dispose of the oil in the environment and perform disassembly operations respecting the environment and the regulations in force.

Level Check

Every 8 hours	Check the hydraulic oil level in the tank.
----------------------	--

Before checking the correct hydraulic oil level, place the machine on a flat and solid surface.

The correct level is obtained at the point at which, when cold, the oil does not exceed the notch on the level dipstick

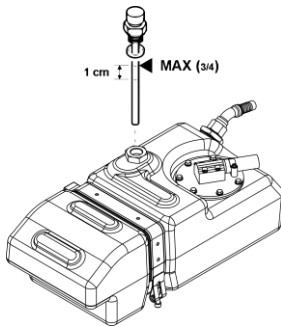

fig. 50 – Oil Level

(approximately $\frac{3}{4}$ of the tank) and does not fall below the notch beyond 1 cm (see fig. 50).

Level Top-up

- Unscrew the vent cap located on the tank;
- Top up the level by adding specific oil through the hole;
- Screw the vent cap back on, repositioning the dedicated seal, and start the engine following the correct procedure;
- Briefly operate the driving and control levers.

- Stop the engine and check again that the oil level on the dipstick is correct and, if necessary, repeat the operation.

Replacement

Every 300 hours	Change the hydraulic oil in the tank.
------------------------	--

To replace the hydraulic oil, use a suitable suction device and a dedicated temperature thermometer.



DANGER: the hydraulic oil can reach high temperatures: before emptying the tank, make sure that the oil is not hot to avoid the risk of burns.



DANGER: always perform the emptying operation with the engine off and the container locked with the dedicated bar.

First empty the tank (*see fig. 51*);

- Unscrew the vent cap “A” of the tank, also removing the seal “B”, and suction out the oil using a suitable aspirator;
- Fill the tank through the hole “C” of the cap/vent until reaching the upper line of the indicator;
- Screw the vent cap “A” back on, inserting the seal “B” and start the engine;
- Briefly operate the driving and control levers;
- Stop the engine and check that the level reaches the notch “D” and, if necessary, restore it;
- After 8 hours of work, check the level again.

4.3.2. HYDRAULIC OIL FILTERS

Your machine is equipped with filters on the hydraulic oil circuit, located in the lower part of the frame, under the container.

The immersion type filters are screwed directly into the hydraulic oil tank, which is easily accessible by lifting the machine container.



DANGER: always replace the filters with the engine off and with the container locked with the dedicated bar.



OBLIGATION: Dispose of the oil and filters respecting the environment and the current legislation.

**Every 300
hours**

Replace the filters and the hydraulic oil.

To replace the filters follow the instructions below, with reference to *fig. 51*.

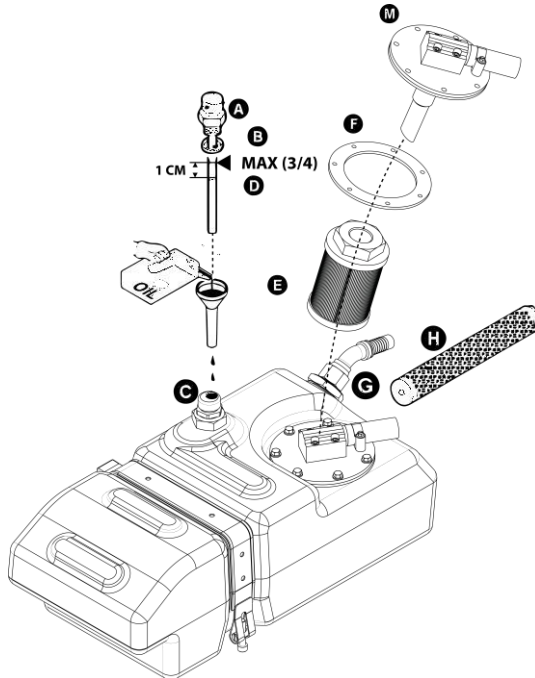

Fig. 51 – Oil and filters replacement

Replacement

- Empty the oil tank, following the procedure indicated above;
- Loosen the fixing screws “M” from the oil tank cover;
- First, replace the filter “H” mounted directly in the hydraulic oil tank;
- Unscrew the coupling nipples “G”;
- Replace the filter “H” and tighten the nipple back on, paying attention to the position of the seal;
- To change the filter “E” it is necessary to loosen the coupling sleeve “F”;
- Unscrew the filter “E” from the fitting;
- Screw the fitting “F” on the new filter “E” always interposing the seal;
- Screw the sleeve back onto the inlet tube in the tank;

- After replacing the filters, apply high temperature resistant sealant “L” on the closing edge of the lid, put the lid on the tank and tighten the screws “M”;

Fill the tank and check the oil level as previously seen (see the oil table at the end of chapter 4).

3.4. TRACKS

Adjustment

Every 50 hours Adjust the tension of the tracks.

Correct tensioning of the tracks is important to ensure their durability and for your safety: to check it, simply apply a force of 5 kg on the track and check that the camber is approximately 15mm.

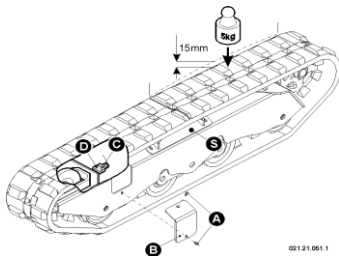

Fig. 52 - Track tension adjustment

To adjust the track tension correctly:

- Remove the cover “B” by loosening the two screws “A”;
- Using two wrenches, loosen the lock nut “C”;

- Adjust the tension by acting on the nut “D”;
- Check that the camber is 15mm near the front or rear centre line with respect to the central guide “S” of the track (see fig. 52);

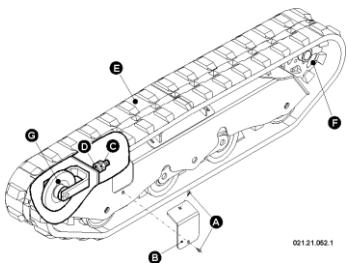

Fig. 53 - Track replacement

- Once the adjustment has been made, lock the lock nut;
- Refit the lid;
- Repeat the same operations for the other track.

Replacement

To replace the tracks:

- Lift the side of the machine to be operated on using the hydraulic jacks or a crane;
- Place the machine on suitable

stands, checking its stability;

- Remove the cover “B” by loosening the two screws “A”;
- Using two wrenches, loosen the lock nut “C” and unscrew both the lock nut and the nut “D” fully, loosening the track completely;
- Extract the track “E” starting from the front;

- Mount the new track by meshing it with the teeth of the drive wheel “F”;
- Fit the front part of the track onto the idle wheel “G”;
- Adjust the tension by acting on the nut “D”;
- Check that the camber is 15mm near the front or rear centre line with respect to the central guide “S” of the track (*see fig. 52*);
- After adjustable, lock the lock nut “C”;
- Refit the lid;



DANGER: never work with the machine raised on the jack or suspended, but always rest it on stands suitable to support the weight of the machine before starting work.

3.5. GREASING

Every 8 hours Top up all the required points with grease.

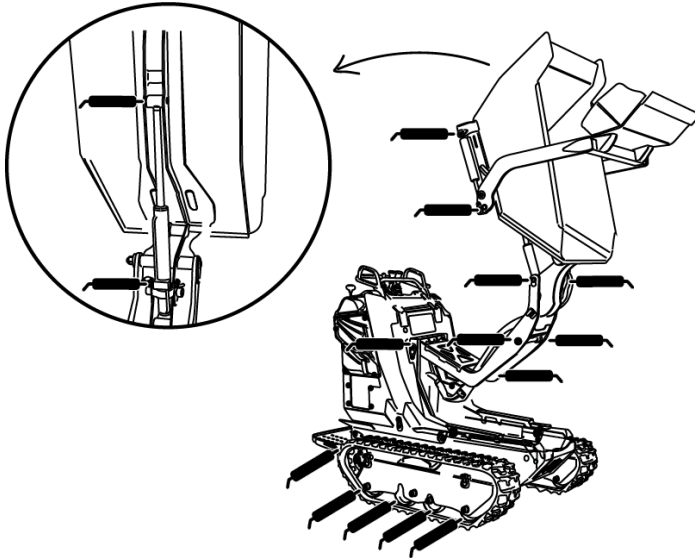

fig. 55 – Greasing points

Fill all the greasing points provided with grease, using a dedicated greaser. In addition, grease the drive levers using a spray-type grease can.

3.6. RECOMMENDED LUBRICANTS

	<i>Type</i>	<i>Quantity</i>
Engine Oil	10W - 40W	
Hydraulic Oil	TITAN HYD 32 HVI	19 l
Grease	MR Filante	

4. PROBLEMS AND FAULTS

Problem	Cause	Solution
Hydraulic oil comes out of the vent	Excessive oil level	Fill to the correct level
	Oil overheating	Interrupt the work and allow to cool
	Hydraulic circuit fault	Arrange for the machine to be checked by a workshop with the specific competences
Oil leaks	Excessive oil level	Fill to the correct level
	Fault with the hydraulic circuit or with the seals	Arrange for the machine to be checked by a workshop with the specific competences
The hydraulic controls do not respond correctly.	Oil level too low	Fill to the correct level
	Hydraulic circuit fault	Arrange for the machine to be checked by a workshop with the specific competences
The container moves slowly	Oil overheating	Interrupt the work and allow to cool
	The engine has no power.	Arrange for the motor to be checked by a workshop with specific competence
Excessive oil temperature.	Oil level too low	Fill to the correct level
	Overheating	Interrupt the work and allow to cool
The parking brake does not disengage	The brake cable is broken	Arrange for the cable to be replaced by a mechanical workshop
	The brake is locked	Move the machine slightly forward and/or backward and try again
The machine does not move	The parking brake is engaged	Release the brake
	There is no oil in the hydraulic circuit	Restore the correct oil level
	The tracks are broken	Replace the tracks
	Hydraulic component fault	Arrange for the machine to be checked by a workshop with the specific competences
Excessive noise from the tracks when moving	Incorrect track tension	Restore the correct tension
	Broken or worn tracks	Replace the tracks
	Failure of bearings or rollers	Arrange for the machine to be checked by a mechanical workshop
Excessive noise from the container	Insufficient grease	Grease
	Faulty bearings.	Arrange for the machine to be checked by a mechanical workshop
The accelerator is not responding	The accelerator cable is broken	Arrange for the cable to be replaced by a mechanical workshop
The engine does not work correctly or the noise is excessive	Various	Arrange for the engine to be checked by a mechanical workshop with specific competence
The engine has no power	Clogged air filter	Check the air filter
	Various	Arrange for the engine to be checked by a mechanical workshop with specific competence
The motor does not start	Insufficient fuel	Fill the machine with fuel
	Incorrect start procedure	Follow the correct starting procedure

5. INDEX

General information	1
Manufacturer and machine identification	4
Hi-Tip container lock	5
Platform lock	6
Safety plates	7
Permissible slopes	10
Dimensions	11
Technical data	13
Commands	14
Engine ignition	21
User regulations	22
Stopping and parking	27
Unloading material	28
Using the self-loading arm	28
Lifting the Hi-Tip container	29
Transporting the minidumper	30
Towing	31
Storage	32
Maintenance intervals	33
Motor	34
Refuelling	34
Engine oil control	34
Air filter	34
Hydraulic oil level check	35
Tracks	38
Greasing	39
Recommended lubricants	40
Problems and faults	40

CORMIDI S.R.L.

 VIA FONTE 342
 84069 - ROCCADASPIDE - SALERNO
 TEL.: +39 0828.943688 - FAX: +39 0828.943963

DICHIARAZIONE CE DI CONFORMITA' EC DECLARATION OF CONFORMITY

Il sottoscritto, detentore della documentazione tecnica, dichiara che la sottoindicata macchina è stata progettata e costruita in conformità alle seguenti Direttive Europee, come emendate, alle norme armonizzate citate e ai decreti e regolamenti che le traspongono nelle leggi nazionali:

The undersigned, holder of the technical documentation, declare that the machine described below has been designed and manufactured in compliance with the following European Directives, as amended, the European Standards and the regulations transposing them into national laws:

1. 2006/42/CE "SICUREZZA DELLE MACCHINE/SAFETY OF MACHINERY"			
1.1 NORME EUROPEE ARMONIZZATE NEL CUI RISPETTO LA CONFORMITÀ È DICHIARATA: EUROPEAN HARMONISED STANDARDS UNDER WHICH CONFORMITY IS DECLARED:			
EN 474-1:2004 + X		EN 474-3:2004 + X	EN ISO 3471:2008 X
A1:2009		A1:2009	EN ISO 3449:2008 X
1.2 PRINCIPALI COMPONENTI DI SICUREZZA MONTATI E FORNITI CON LA MACCHINA MAIN SAFETY COMPONENTS INSTALLED AND SUPPLIED WITH THE MACHINE			
1.2.1 VARIANTE PER LA MOVIMENTAZIONE DEI CARICHI SOPESE OBJECT HANDLING APPLICATION KIT [EN 474-5 PUNTI 4.1.7.3 - 4.1.7.5]			NO X
1.2.2 STRUTTURA DI PROTEZIONE CONTRO LA CADUTA DEGLI OGGETTI (F.O.P.S.) FALLING OBJECT PROTECTIVE STRUCTURE (F.O.P.S.)			X
2. 2000/14/CE "EMISSIONE ACUSTICA/NOISE EMISSION"			
2.1 PROCEDURA DI VALUTAZIONE DELLA CONFORMITÀ SEGUITA CONFORMITY ASSESSMENT PROCEDURE FOLLOWED			
2.2 NOME ED INDIRIZZO DELL'ORGANISMO NOTIFICATO COINVOLTO NAME AND ADDRESS OF THE NOTIFIED BODY INVOLVED		ALLEGATO VI (ART. 6/1) ECO CERTIFICAZIONI SPA (N. 0714) - ITALY VIA MENGOLINA, 33 - FAENZA (RA)	
2.3 LIVELLO DI POTENZA SONORA MISURATO L _{WA} (REF. 1 PM) MEASURED SOUND POWER LEVEL L _{WA} (REF. 1 PM)			100 dB (A)
2.4 LIVELLO DI POTENZA SONORA GARANTITO L _{WA} (REF. 1 PM) GUARANTEED SOUND POWER LEVEL L _{WA} (REF. 1 PM)			101 dB (A)
2.5 POTENZA NETTA MOTORE INSTALLATA (COME DEFINITA DALLA DIRETTIVA 97/68/CE) ENGINE NET INSTALLED POWER (AS DEFINED BY THE EUROPEAN DIRECTIVE 97/68/CE)			4.1 kw
3. 2004/108/CE "COMPATIBILITÀ ELETTROMAGNETICA/ELECTROMAGNETIC COMPATIBILITY"			
3.1 NORME EUROPEE ARMONIZZATE NEL CUI RISPETTO LA CONFORMITÀ È DICHIARATA EUROPEAN HARMONISED STANDARDS UNDER WHICH CONFORMITY IS DECLARED			EN 13309:2000
4. ALTRE DIRETTIVE EUROPEE APPLICABILI/OTHER APPLICABLE DIRECTIVE/S:			
5. COSTRUTTORE/MANUFACTURER: CORMIDI S.R.L. - VIA FONTE 342 - 84069 - ROCCADASPIDE - SALERNO			
6. MACCHINA/MACHINER:		Autoribaltabile a cingolo compatt /Crawler	
7. TIPO/TYPE: 9. ANNO DI COSTRUZIONE/CONSTRUCTION YEAR		8. MATRICOLA N°/SERIAL N°	
C.6.60 DHE 2010			
10. PERSONA AUTORIZZATA A COMPILARE IL FASCICOLO TECNICO/PERSON AUTHORISED TO COMPLETE THE RELEVANT TECHNICAL DOCUMENTATION			
ARMANDO CORMIDI - VIA FONTE, 342 - 84069		ROCCADASPIDE (SA)	

 DICHIARAZIONE N°

ROCCADASPIDE



CORMIDI C55 SERIES