

# THOROUGHCLEAN

WATER BLASTERS

Congratulations on purchasing one of Australia's  
Toughest high pressure water blasters.  
*Superior Cleaning— designed to last!*

## OPERATORS MANUAL

### for 10 hp YANMAR DIESEL DRIVEN **HOT WATER** PRESSURE CLEANERS

**Apply to MODELS:**

**Skid-Mounts:** D10M-36H, D10M-36H-BB, D10M-36H-BBO

**Trailer Mounts:** D10M-36H-T, D10M-36H-TO, D10M-36H-TD



### Index:

**Page:**

- 2 Technical data / Specifications
- 3 Installation & Start-up
- 4 Operating Tips, Shutting down, Regular Checks
- 6/7 Maintenance Schedule
- 8/9 Trouble Shooting Guide
- 10 What can cause expensive damage to your machine
- 11 **WARNINGS & SAFETY INSTRUCTIONS**
- 12 MEDIC ALERT Information
- 13/14 Warranties
- 15 Terms & Conditions of Sale
- 16 Pump info, by-pass valve info, electrical plan

**Manufactured by:**

**ThoroughClean Water Blasters**

12 Ashburn Road, Bundamba,

QLD 4304, Australia

Ph: +61 (0) 7 5467 2025

[www.thoroughclean.com.au](http://www.thoroughclean.com.au)

Model & Serial: .....

Date of Purchase: .....

Purchased from: .....

	<b>D10M-36H</b>	<b>D10M-36H-BB</b> <b>D10M-36H-BBO</b> 'O' = Oval tank	<b>D10M-36H-T</b> <b>D10M-36H-TO</b> 'O' = Oval tank	<b>D10M-36H-TD</b> 'D' = Double Axle
<b>Build Spec</b>	Mine	Mine	Mine	Mine
<b>Boiler &amp; Temp</b>	Diesel - 70°C. 21 lit. fuel tank	Diesel - 70°C. 21 lit. fuel tank	Diesel - 70°C. 21 lit. fuel tank	Diesel - 70°C. 21 lit. fuel tank
<b>Frame Type</b>	Skid	Skid with 1000 litre tank	Trailer with 1000 litre tank	Trailer with 2000 litre tank
<b>Engine</b>	YANMAR 10 hp	YANMAR 10 hp	YANMAR 10 hp	YANMAR 10 hp
<b>Model</b>	L100N – 1 Cylinder Air cooled, 442 cc	L100N – 1 Cylinder Air cooled, 442 cc	L100N – 1 Cylinder Air cooled, 442 cc	L100N – 1 Cylinder Air cooled, 442 cc
<b>Start</b>	Electric + recoil	Electric + recoil	Electric + recoil	Electric + recoil
<b>Gearbox</b>	2:1 reduction	2:1 reduction	2:1 reduction	2:1 reduction
<b>Battery</b>	•	•	•	•
<b>Battery Box</b>		•	•	•
<b>New HAWK Pump Model</b>	NPM1525R	NPM1525R	NPM1525R	NPM1525R
<b>Old HAWK pump model</b>	HC456	HC456	HC456	HC456
<b>Max Pressure &amp; Flow</b>	3625 psi 15 lpm	3625 psi 15 lpm	3625 psi 15 lpm	3625 psi 15 lpm
<b>Set-up / de-rated pressure &amp; flow</b>	2600 psi 15 lpm	2600 psi 15 lpm	2600 psi 15 lpm	2600 psi 15 lpm
<b>Nozzle size at set-up pressure</b>	#15045	#15045	#15045	#15045
<b>Pump Speed RPM</b>	1450	1450	1450	1450
<b>Hour Meter</b>	•	•	•	•
<b>Engine-Pump vibe-mounted</b>	•	•	•	•
<b>Slave Oil Tank to pump</b>	•	•	•	•
<b>S/steel Water Break Tank</b>	• (if required)			
<b>Low water engine shut-down</b>	• (if required)	•	•	•
<b>Soft-acting By-pass Valve</b>	•	•	•	•
<b>Thermoshield Protection</b>	•			
<b>Built-in Reel</b>	•(Optional without)	•	•	•
<b>Hose length</b>	30m	30m	30m	30m
<b>Water Tank</b>		1000 lit. IBC 1000 lit. Poly	1000 lit. IBC 1000 lit. Poly	2000 lit. IBC 2000 lit. Poly
<b>Ind. Water Filter</b>	•	• (double)	• (double)	• (double)
<b>Gun &amp; 900 mm s/steel lance</b>	•	•	•	•
<b>Weight:</b>	335 kg	~400 kg (tbc)	~600kg / ~650kg	~1,100 kg (tbc)
<b>Size (L x W x H) cm</b>	133 x 71 x 150	224 x 122 x 140 274 x 122 x 110	3.6 x 1.85 x 1.8 4.1 x 1.85 x 1.5	TBC
<b>Mine Spec Features</b>	As Specified	As Specified	As Specified	As Specified

## **Read WARNINGS & SAFETY INSTRUCTIONS before operating machine**

### **INSTALLATION**

- Inspect shipment for damages during transit and unpack

### **WARNING – PLEASE READ SAFETY INSTRUCTIONS FIRST!**

- For Skid Mounted machines with no on-board water tank: Connection supply hose to water supply:
  - Important: Use hose with minimum 20 mm inside diameter
  - Required pressurised water supply (not gravity) with minimum of 10 PSI and ~20% more flow than pump flow rate (litres per minute)
  - Turn on the water supply (open tap fully). Water will fill the break tank if fitted

For Skid-mounted units with water tanks and Trailer-mounted units – ensure tank has enough water and the water level is at least above the low level float switch otherwise the engine won't start

- Unroll the hose fully ensuring there are no kinks in it
- Trigger gun to expel any air in the system

### **LAST CHECKS & START:**

- Check all hoses are connected and check for damage or water leaks
- Check diesel fuel levels in both engine and Boiler fuel tank
- Check oil level in the pump. The oil sight glass should be HALF full – not more! If oil need to be topped up, use SAE10W40 or SAE 15W40 or SAE30 and top up at the Slave Oil Tank if fitted, otherwise on the pump itself.
- Ensure water supply tap (on portable machines) or tank ball valves (on skid mounts and trailers -if fitted between tank and water filters) are wide open



### **Control Box:**

- Ensure that the Emergency Stop button is not engaged
- Switch on by turning the ENGINE ON/OFF switch to the ON position or press the GREEN START button. The machine will fire up, start pumping and the RED & ORANGE indicator light will be off.
- The engine is now running, pump is pumping and water is running in by-pass.
- Pull the trigger on the gun by pointing the lance in a safe direction.
- When the trigger is released, the pump is still pumping and water is in by-pass.

### **TO ENGAGE HOT WATER:**

- Turn BOILER ON/OFF switch to ON. The GREEN Indicator Light will be lit.
- Boiler will fire up and hot water will start to flow after a few seconds of water blasting.
- The water temperature is pre-set and can not/should not be changed. 99% of fates and oils melt below 70 degrees Celsius and by keeping water temperature to 70 degrees allows a higher flow rate to be heated, saving on fuel, longer life from coil and other components.

## FAULT INDICATOR LIGHTS:

- For units fitted with control boxes with indicator lights: The RED light is an engine fault indicator light – check engine oil (low pressure) and check that engine isolator switch is not engaged.
- The ORANGE light is a water fault indicator light: Check water level or water supply when lit.  
**REMEMBER: Check Oil Levels DAILY!**

## NOTE:

- During the first 10 to 12 hours of operation, manufacturing debris like SWARF / LOCTITE may come through the machine and cause blockages of the high pressure jet. Switch the machine off, trigger the gun to release stored pressure, remove nozzle and clean if this occurs.
- Do not crank the engine excessively – no more than 10 – 20 seconds at a time. Allow 2 minutes for starter motor to cool down.
- **Engine REVS is locked!** Do not unlock or change as this will void your warranty. Engine revs has been set so engine is running at peak engine torque curve at comfortable revs – set to the power requirement for the pump, pressure and flow.  
**DO NOT ALTER!**

## OPERATING/CLEANING TIPS:

1. Using a Fan Jet, first blast off heavy soil or dirt build-up. The unit comes standard with a 15 degree nozzle correctly sized for the pressure and flow for your machine. Always use the same size nozzle (NEW) to test the machine for performance
2. Apply detergent to partially cleaned surface using low pressure. (Apply detergent by spraying from bottom up to avoid streaking - using a dual-lance and detergent assembly.) Allow to soak for a few minutes.
3. Blast off dirt using high pressure and a 'bottom - up' approach.
4. Lastly, rinse off thoroughly with 'top down' approach.

## SHUTTING DOWN:

**IMPORTANT** – ALWAYS turn boiler off first (by turning the Boiler ON/OFF switch to the 'OFF' position) and run cold water through the system by blasting with cold water for 3 – 5 minutes before shutting down!

- Turn the ON/OFF switch to OFF
- Turn off water supply and disconnect from water supply (Portable skid units only)
- Squeeze gun several times to release any stored pressure
- Lay out high pressure hose straight and then reel back up onto reel (if fitted with reel)
- Lock reel into place using the barrel bolt (only on Trailers and Skid-mount units)

## REGULAR CHECKS:

- **Check all oil levels :**
  - KOHLER engine oil level – check dip-stick. Use manufacturer's recommendations.
  - Gearbox oil level (sight glass should be half) SAE80W90 Gearbox oil.
  - Pump oil level (sight glass should be half full) SAE 15W40 / SAE 10W/40 SAE 30
- **Water Supply** - Low water supply can cause cavitation and/or pump running dry causing expensive pump failure. Always check to ensure supply is:
  - Uninterrupted
  - Pressure is good (10 PSI / 30 LPM)
  - There are no kinks in supply hose
  - Fittings are in good condition and not leaking
- **Worn Jets** -System will function okay, but with oversized, worn jets, the pressure will be much lower and cleaning ability reduced. Always use new jets to check operation efficiency
- **Operating Pressure** - Check operating pressure to see if it within 10% of units specified operating pressure. If pressure drops over time it may indicate general wear and tear and a service is recommended.

- **Air Leaks** - Especially in suction to pump hoses. Repair immediately if found. Check for cuts & abrasions
- **Lance & Gun assemblies** - Check for damage and leaks
- **Filters** - Check to ensure filters are clean, filter heads/tops are not cracked, seals are not worn and sealed air tight and mesh tube is unblocked
- **Motor Speed** - Check unit if motor speed is too low. If motor makes a humming sound, switch off immediately. Do not use extension cords on these units – plug straight into wall socket!
- **SAFETY** - Ensure safety protective gear is used and in good state of repair. Ensure Safety MEDIC ALERT Card is handy.
- **Prolonged by-pass** - Leaving the unit in prolonged by-pass (machine is switched on but trigger is not depressed) can cause excess wear & tear due to water over-heating which damages seals. Portable units have a safety mechanisms built in to prevent damage:
  - Automatic dumping of hot water when water temp rises above 63 deg C.
- **Worn By-Pass Valves** - Soft-Acting By-Pass valves should NOT store high pressure water in hose down-stream between by-pass valve and high pressure gun.
- **Water Leaks** - Excessive hammering can cause damage. Fix leaks when they occur
- **Water Condition** - Ensure water source is clean (potable water). Not recycled water or bore water which can damage pumps.
- **Tyre Pressure** – Trailer mounted units only
- **Mechanical Brake System** – Check all bolts and nuts – tighten if necessary

**Remember to check filters regularly and clean under running water.**

The correct procedure for replacing the filter mesh in the small black filters (vs the large grey filters) is to first put the mesh into the cup after rinsing under running water and then screw it back onto the filter head. This is the opposite of replacing the filter mesh in the large filters.



**Correct procedure of replacing LARGE filter cartridges on large grey filters:**

- Always put the filter mesh tube into the black 'head' first (the part mounted on the frame) ensuring it is square and tight.
- Now screw on the grey cup part of the filter.

Doing it the opposite way may result in a crushing of the filter mesh!



## MAINTENANCE SCHEDULE:

This maintenance schedule does not include the **Engine** Maintenance Schedule. Please refer to KOHLER Operators Manual or the HONDA website.

	ACTION REQUIRED	DAILY	50 HRS	250 HRS	500 HRS	ANNUAL
1.	Replace high pressure nozzle/jet		As required	YES	YES	YES
2	Check Water Filters – Clean or Replace if damaged	YES	YES	YES	YES	YES
3	Inspect for leaks and repair all HP Accessories like gun, hose, swivel, hose reel swivel, nozzle	YES	YES	YES	YES	YES
4	Inspect all electrical cabling for damage or wear – repair by qualified electrician	YES	YES	YES	YES	YES
5	Check High Pressure Switch & Flow Switch and replace if faulty		YES	YES	YES	YES
6	Check Oil level in Pump (sight glass half full)	YES	YES	YES	YES	YES
7	CHANGE pump oil – SAE 15W40 / SAE 30		YES	YES	YES	YES
8	Check Oil level in Gearbox (sight glass half full) and top up with SAE 80W90 Gearbox oil	YES	YES	YES	YES	YES
9	Service transmission, change oil – SAE 80W90			YES	YES	YES
10	Strip and Refurbish pump: - Replace Plunger Rod Oil Seals (3/pump) - Replace Brass Valves (6/pump) - Replace various seals (3/pump) - Replace Ceramic Piston Plungers if cracked or worn (3/pump)					Only if required
11	Check By-Pass valve function test - re-kit or replace if required			YES	YES	YES
12	Function test all Safety Shutdowns			YES	YES	YES
13	Check engine sub-frame vibe mounts			YES	YES	YES
14	Check Boiler electrode gap – set to 3-5 mm		YES	YES	YES	YES
15	CONTROL PANEL – Have an Authorised Electrician Fully Function Test - Repair or Replace all Electrical Components.	As required or annually				
16	Replace boiler tank fuel filter element			YES	YES	YES
<b>TRAILERS</b>						
17	Re-tighten all nuts & bolts on spring suspension, tow-bar hitch, mechanical brakes. Check tension on mechanical brake cable.		YES	YES	YES	YES
18	Check Tyre Pressure – inflate if necessary	Daily Check				

## MAINTENANCE TIPS:

### USE THE FOLLOWING GUIDE WHEN CONSIDERING MAINTENANCE:

Always test your machine using a new high pressure nozzle - correctly sized for set-up pressure and flow.

### Before you start pulling pumps apart, do obvious checks first:

- Worn /blocked Jets
- Air Leaks
- Engine Speed (Not too low)

- Power Supply (Not too low when using long leads on 240 Volt units)
- Suction Filters (Blocked?)
- Water supply volume (Not too low)

**As a guide in normal use, consider the following:**

- After replacing 10 x high pressure Stainless Steel jets/nozzles, it is time to replace the seals on the pump using a Seal Kit.
- At the same time, also replace the seals on the By-Pass Valve using a By-Pass kit, or if economically viable, replace by-pass valve.
- By-Pass Valves will take 3-5 rebuilds before body wear becomes too much and replacement is needed.
- Pistols, swivels & H.P. Hoses are usually uneconomical to repair. Replace as necessary.

## TROUBLE SHOOTING GUIDE

PROBLEM	POSSIBLE CAUSE	REMEDY	COMMENT
<b>MACHINE WILL NOT START</b>	Power not plugged in and switched on	Plug into appropriate outlet and switch on at the wall, then at the machine	If Electrical
	No Fuel	Check Fuel. Re-fill fuel tank.	If Petrol or Diesel
	No Fuel	Open fuel tank ball valve or fuel solenoid tap	If Petrol or Diesel
	No or low water supply	Check water supply	If fitted with break tank and auto shut-down
	Float switch sticking	Check float switch in water tank	If fitted
	Emergency-Stop engaged	Disengage	If fitted
	Battery Isolator switch engaged	Disengage	If fitted
	Starter Isolator Switch engaged	Disengage	If fitted
	Pump oil level too low	Top up with SAE15W40 or SAE30	If fitted with low level switch
	Pump oil over temp	Allow to cool down	If fitted with oil over temp switch
Boiler over temp	Allow to cool down	If fitted with over temp switch	
Timed by-pass shutdown	First switch off and then on again	Some electrical units	
<b>THE PUMP RUNS BUT DOES NOT PRODUCE NOISE OR PRESSURE</b>	The pump is not primed and is running dry	Check if there is water in the suction line Check if the gun is open Check if nozzle is not blocked Check that the valves are not blocked	
<b>SHORT PLUNGER SEAL LIFE</b>	Cavitation or air in the system Damaged ceramic plunger Excessive pressure and/or temp in the pumped water	Check suction hose. Increase diameter size for bigger supply Replace Plunger Check the temperature and pressure of inlet water	
<b>SHORT BEARING LIFE</b>	Problems with pump-motor connection The oil has not been changed regularly Excessive pressure of pumped water	Check status of drive shaft keys, flexible coupling or pulley Change oil as instructed in the maintenance schedule Check the pressure	
<b>MACHINE RUNNING OKAY, BUT NOT REACHING SPECIFIED PRESSURE</b>	Sucking air Valves Sticking Seat in Unloader Valve Worn/ By-Passing Water HP Jet Wrong Size – Worn Out Worn Piston Plunger H.P. Seals Pressure control valve not set right Low speed/rotation Insufficient Water Supply	Check Suction for Air Leaks Remove – Clean – Replace Remove – Fit BPV Service Kit Or Exchange Valve Check – Replace Check – Replace Calibrate valve. Check seal seat Check motor revs and drive Check Available Water Supply. Clean Filters in Suction Line. Increase supply hose size	Check Water Quality Probably Indicate Service Required  Check Pistons for Cracks
<b>FLUCTUATING PRESSURE</b>	Valves Worn/Sticking Blockages/Debris in By-Pass Valve Pump Sucking Air Jet too small Worn Piston HP Seals	Remove – Clean – Replace Remove – Clean – Replace Seal Suction Check correct size and replace Remove – Clean – Replace	Check Water Quality Check Filters for damage  Service Required



<b>PSI LOW AFTER PERIOD OF USE</b>	Fair Wear / Tear? Suction/Delivery HP Outlet Valves Worn Unloader Valve Worn Piston Seals Worn  Piston Cracked "O" Rings Failed/Leaking "Big End" Worn Drive Belts Loose (if belt driven)	Check – Replace HP Jet Check – Replace  Replace as required Replace as required  Replace as required Replace as required Replace as required Check / Tighten	Check Recent Activity/Usage Therefore Check suction Filters  Check Big Ends for Piston Slap Check Big Ends for Piston Slap
<b>PUMP VERY "NOISY"</b>	Air in Suction / Pump Cavitating Problem with pump-motor connection Broken or Weak Suction Valve Spring Valves Clogged/Sticking Worn Main Crankshaft Bearings  Inlet Water Temp over 75 deg Celsius	Identify Air Ingress/Seal Check gearbox or coupling  Check – Replace – As Set Check – Replace – As Set  Reduce inlet Water Temp	Probably Uneconomical to Repair Left in By-Pass for excessively long periods?
<b>OIL IN PUMP EMULSIFIED/ CONTAMINATED BY WATER (water in the oil)</b>	Piston to Crankcase Oil Seals Worn  Condensation from High Ambient Humidity Piston Seals Worn/Cracked Piston Water Blasted into Pump via Breather Cap during Cleaning	Check and Replace  Replace oil more frequently  Check – Replace Exercise Care	Look for Oil under Pump – Low Pump Oil
<b>WATER DRIPPING FROM UNDER PUMP (Between crankcase and manifold housing)</b>	H.P. Piston Seals Worn or  Worn Plunger Worn Plunger Stop Seal "O" Rings in Plunger Retaining Bolt Worn	Check and Replace Seal Pack  Replace Plunger Replace Seal Check and Replace	
<b>OIL DRIPPING FROM UNDER PUMP (Between crankcase and manifold housing)</b>	Piston to Crankcase (Plunger Shaft) Oil Seals Worn	Check and Replace	Check Pump for Low Oil therefore "Big End" Damage
<b>EXCESSIVE VIBRATION/ PULSATIONS IN HP DELIVERY LINE</b>	Accumulator Failed Worn Seals (Wet end seals) Worn Plunger Seals In/Out Pump Valves Worn Valves full of scale/dirt Pistons Cracked Low Water Supply Gudgeon Pin in Conrod Stretched	Check – Replace Replace if worn Replace if worn Check – Replace Clean or replace Check – Replace Increase supply Check – Replace	
<b>WATER FILTER MESH IS CRUSHED WHEN REPLACED</b>	Incorrect replacement procedure on Grey NY126 Water Filters with Blue or Red mesh tube	First insert mesh tube tightly into the fixed black head of filter assembly and then screw on grey cover /cup tightly.	For small black filters, first insert mesh tube into cover /cup and then screw onto fixed part.

## HOW TO CAUSE EXPENSIVE DAMAGE TO YOUR MACHINE

WHAT WAS DONE WRONG:	WHAT WAS THE RESULT OF THIS ACTION:
Machine was allowed to run dry (without water supply)	Cracked and burnt high pressure seals in pump. No. 1 piston cracked due to thermal shock.
Unit was run on low volume water supply and allowed to cavitate	<b>Mechanical damages to EVERYTHING:</b> <ul style="list-style-type: none"> <li>- Pistol, HP hose, pump valves, pistons</li> <li>- Crankshaft bearing failure</li> <li>- Pressure gauge failure</li> <li>- By-pass valve excessive wear &amp; tear</li> <li>- Frequent O-rings blow outs</li> <li>- Brass heads deformed</li> </ul>
Over adjust by-pass valve to try and increase PSI	Dump pressure was too high. Hydraulic hammer to system every time trigger is closed. PSI was increased 5-fold normal working pressure.
In-Line filter was removed because "It kept blocking up!"	Excessive wear & tear on pistons / valves / seals / HP jets. Excessive blocking of filters caused by bore or recycled water with high salt / mineral content. Pump clogged up with debris. <b>Remember: Spec requirement says: "Potable water"</b>
Over-revved engine for more PSI	Engine & Pump premature wear & tear. (Most increased PSI pressure is lost through by-pass valve and only small increase in pressure is achieved doing this!) Lost of waster horse power!
<b>COMMON MISTAKE:</b> Put a smaller HP Jet onto lance for higher pressure.	When orifice is reduced, the PSI will rise and then by-pass valve will dump (thinking the pistol is shut). Most extra PSI will be dumped and only a slight increase in PSI will be achieved. Engine, By-pass valve & Pump premature wear & tear.
Using Contaminated Fuel ("Had to remove fuel filter to keep engine running!")	Excess Fuel-system clean-outs required. If excessive corrosion in carburetor or injectors is detected after the 2nd or 3rd in-line fuel filter replacement, then this should ring alarm bells.
Park machine where debris blows all over it. Reverse bulldozer over it.	Our machines are rugged and strong – but not battle tanks!
Hire units long-terms and fluid levels are not checked.	Con-rod through the crank case!
Modify 240 Volt electric unit to override thermal overload on motor.	Stop-Start capacitors melted.
Used 100m extension lead and a 5 Kva Gen-Set.	A 10% low current is equivalent to a 50% over-load.  Our 3 hp 240 Volt motors require 8 Kva Gen-Set minimum!
Run trucks, fork-lifts, tracked excavation equipment over hoses and lance assemblies/pressure guns.	Needs replacing of damaged parts

**Read WARNINGS & SAFETY INSTRUCTIONS before operating machine**



**HIGH PRESSURE, HIGH VELOCITY HOT WATER IS DANGEROUS!**

**GENERAL PRESSURE CLEANER WARNINGS AND SAFETY PRECAUTIONS**

- **Caution – HOT WATER. Danger of severe burns. Proceed with caution!**
- When shutting down, always turn off machine, turn off water at the source and trigger the gun pointing the lance in a safe direction to release any in-line stored pressure - before disconnecting hoses or working on machine.
- Never aim high pressure water jet at anyone, at animals or at fragile items - injury or damage could result.
- **Always be aware of overhead cables, run-off water, slippery surfaces and by-standers!**
- Never allow untrained adults or minors use of the equipment.
- Never use the machine if there are any leaks on the high pressure delivery side of the pump.
- Read and observe the manufacturer's instructions if chemicals are being used.
- The “recoil” on larger machines is positive - lean forwards and brace yourself to take it up!!!
- **NEVER HIGH PRESSURE BLAST THE FOLLOWING:** any electrical components, motors / switchgear or electrical boxes as injury or death may result.
- Never water blast any fuel caps or oil caps and water can get into breather holes and contaminate fuel or water. Never blast water directly into seals / bearings on shafts where water penetration would be detrimental.
- **NEVER WATER BLAST:** fragile items / surfaces that may be damaged by high velocity water. Always carefully test on a small area first.
- **ALWAYS WEAR PROTECTIVE GEAR (PPE)** i.e. Head, face, eye protection, wet weather gear, boots and gloves - which is particularly important where hot water or aggressive chemicals are being used or where wet sandblasting is used.
- Keep hands, feet and hair away from all moving parts.
- Never leave machine running unattended.
- **EXTREME DANGER** - never adjust engine speed (RPM) or safety by-pass valve in an attempt to increase pressure!
- Barricade off immediate work area - restrict access - erect hazard warning signs.
- Never use high pressure water cleaner without protective canvas sheaths on operator end of high pressure hose as a high pressure leak can injure operator.
- In commercial / industrial sites class 'b' units (pressures over 5,000 PSI) should have additional operators allocated as safety observer / machine minder subject to work conditions / environment. This is a responsibility of the 'site occupier' to determine.
- If two / three operators are working they should be physically separated by partitions / barriers.
- Prior to high pressure water blasting, check location's level of emergency /first aid.
- All machines are fitted with **MEDIC ALERT** tags. If a high pressure water injury occurs which need medical attention, pull off machine and give it to the medical practitioner to read

## **WARNINGS & SAFETY PRECAUTIONS SPECIFIC TO THIS MACHINE:**

- **This machine produces HOT WATER at high pressure – take extreme caution!**
- **Severe burns and injury can result. Beware of hot exhaust air, hot chimney and a hot lance!**
- Use only Clean / Fresh POTABLE Water - NOT Mine recycled water.
- Always be conscious of High Velocity Hot Water from this machine which can cause serious injury and burns
- Run up and test all safety shutdowns regularly i.e. Monthly.
- NEVER attempt to modify levels of performance by:
  - • Adjusting By-Pass Valve to increase P.S.I.
  - Use Under-sized High Pressure Nozzles.
- **EXTREME DANGER!** Use Specified and approved Personal Protection Equipment (PPE) for High Pressure Cleaners. This is a High Performance High Pressure Cleaner. At a Minimum wear:
  - Overalls /boots /thick heavy gloves /full face protection.
  - Additional equipment as instructed by site personnel or Australian regulations for high pressure water jetting

### **An injury by high pressure water jets can be serious!**

#### **In the event of any waterjet injury:**

- Seek medical attention immediately – do not delay
- Inform the doctor of the cause of the injury
- Show the doctor the MEDIC ALERT information in this document or by pulling the safety tag off the machine and taking it with you to the doctor
- Tell the doctor what type of project/task was being performed at the time of the injury making special note of any chemicals that were used and the quality of the water

#### **MEDIC ALERT INFORMATION:**

**ALWAYS ENSURE MACHINE IS FITTED WITH A REMOVEABLE MEDICAL ALERT / WARNING TAG AND TAKE THIS TO A MEDICAL PRACTITIONER WHEN A HIGH PRESSURE WATER INJURY OCCURS.**

#### **MEDIC ALERT INFORMATION:**

This patient may be suffering from a water-jet injury. Evaluation and management should parallel that of a gunshot injury. The external manifestations of the injury cannot be used to predict the extent of internal damage. Initial management should include stabilization and a thorough neurovascular examination. X-rays can be used to assess subcutaneous air and foreign bodies distant from the site of injury. Injuries to the extremities can involve extensive nerve, muscle, vessel damage, as well as cause a distal compartment syndrome. Injuries to the torso can involve internal organ damage. Surgical consultation should be obtained.

Aggressive irrigation and debridement is recommended. Surgical decompression and exploration may also be necessary. Angiographic studies are recommended pre-operatively if arterial injury is suspected. Bandages with a hygroscopic solution (MgSO<sub>4</sub>) and hyperbaric oxygen treatment have been used as adjunctive therapy to decrease pain, edema and subcutaneous emphysema. Unusual infections with uncommon organisms in immuno-compromised patients have been seen; the source of the water is important in deciding on initial, empiric antibiotic treatment and broad-spectrum intravenous antibiotics should be administered. Cultures should be obtained.

## **THOROUGHCLEAN LIMITED WARRANTY**

In order to take advantage of the ThoroughClean limited warranty, you must have maintenance performed according to the schedule (contained in the relevant owners manual supplied with this product), by an authorised ThoroughClean dealer or ThoroughClean service technician. You are free to have your ThoroughClean product serviced by any suitably qualified mechanic or electrical (depending on the requirement mechanical or electrical) and this will not affect your statutory warranties, however, failure by the owner to have the recommended servicing carried out by an authorised ThoroughClean dealer means that you cannot take advantage of the ThoroughClean limited warranty.

In order to ensure your safety, we strongly recommend that you only use an authorised ThoroughClean dealer for servicing. Only authorised ThoroughClean Dealers have access to all of the special tools, technical information, parts and training required to maintain your ThoroughClean product in peak operating condition.

ThoroughClean warrants each new ThoroughClean Pressure Cleaner to be free from defects in material and workmanship under normal domestic and Industrial use and service for the period specified below, conditional to the limitations and exclusions printed on this page. This warranty applies only to new ThoroughClean pressure cleaners distributed in Australia by us and by our authorised ThoroughClean dealers.

### **LIMITED WARRANTY**

Our goods come with guarantees that cannot be excluded under the Australian Consumer Law. You are entitled to a replacement or refund for a major failure and compensation for any other reasonably foreseeable loss or damage. You are also entitled to have the goods repaired or replaced if goods fail to be of acceptable quality and the failure does not amount to a major failure.

The benefits to the consumer under this warranty are in addition to other rights and remedies of the consumer under a law in relation to the goods sold under warranty.

### **Warranty Period/s:**

- 1 year ThoroughClean Manufacturer's Warranty on Build (Defects in material and workmanship)
- 5 year ThoroughClean Manufacturer's Warranty on Galvanized Frames and Galvanized Reel (Defects against rust & welding cracks)
- 12 months ThoroughClean Warranty on Pressure Pump (Note: Maintenance is not warranty. Excludes service and consumables required at scheduled maintenance intervals)
- 2-year Manufacturer's Warranty on Electric Motors
- 3-year HONDA GX Warranty on HONDA engines. Please see [www.hondapowerequipment.com.au](http://www.hondapowerequipment.com.au) for details
- 3-year or 2000 hours Manufacturer's Warranty on KOHLER engines (whichever comes first) (See KOHLER Owners Manual and website for details)

### **Responsibility of the Consumer under this Limited Warranty:**

- Only clean, potable water should be used through our pressure cleaners with a flow rate at least 15% more than the pump requirements (e.g. an 18 LPM pump requires at minimum a water supply of 21 LPM to prevent pump cavitation)
- Strict adherence to the maintenance daily checks and schedule with proof of scheduled maintenance service required by an authorised agent or qualified mechanic and/or electrician.
- Maintenance Services is not covered under warranty. (Warranty excludes normal maintenance and consumables like oil, nozzles, swivels, filter mesh, HP hose, guns, by-pass valves)
- It is the consumer's responsibility to deliver the machine in question to our service premises or to the premises of our appointed agent at the consumer's expense for replacement or repair as applicable.

**Claim Procedure:**

- Contact ThoroughClean by phone or e-mail informing us of your pressure cleaner's problem or defect.
- Once the extent of the claim has been assessed, we retain the right to compensate the consumer for such defect, or repair (pars & labour), or replace the machine under warranty.
- All warranties will be carried out by ThoroughClean authorised staff or appointed agents at a premises to be determined by the Manufacturer.
- It is the responsibility (and cost) of ThoroughClean or our appointed agent to return the machine to be repaired or replaced under warranty to the consumer – this is valid for Australian territories only.
- Where the specific warranty component (e.g. engine) is a Manufacturer's warranty other than ThoroughClean (e.g. HONDA), the consumer can either contact ThoroughClean or the applicable Manufacturer for repairs where such warranty was registered with that Manufacturer at purchase.
- Warranty calls will only be carried out during normal working hours and only by our representatives and not via client's choice of repairer. We will not accept back charges for any work not carried out by our representatives, or accept any charges due to equipment being un-operational for any reason even during its warranty period.

**THIS WARRANTY WILL NOT APPLY TO:**

- Any part/component that has been subject to misuse, negligence, accidental damage, improper or inadequate maintenance or improper storage.
- Any part that has been subject to misuse, negligence, accidental damage, improper or inadequate maintenance, or improper storage.
- Repair rendered necessary or arising from the use of parts or components other than approved by the manufacturer in writing.
- Normal maintenance, replacements of service and consumable items including but no limited to nozzles, seals, oil, guns, swivels, filters, by-pass valves and HP hose.
- Deterioration of any item due to normal use, fair wear and exposure unless due to a defect in material or workmanship.
- Any work or adjustment performed by persons other than authorized ThoroughClean service staff or authorized dealers or damage resulting there from.
- Any damage that results from operating methods other than those indicated in the owner's manual, or use beyond the limitations or specifications as published in the Specification Sheets of the particular model.

**WARRANTY CONTACT INFORMATION:**

Tel +61 (0) 7 5467 2025

Fax +61 (07) 5467 2026

**service@thoroughclean.com.au**

12 Ashburn Road, Bundamba, Queensland  
4304, Australia

**SERVICE & PART ORDERING**

For service and ordering parts, please call 1300 378 872 or 07 5467 2025

**Or your nearest ThoroughClean Distributor**

We have very knowledgeable, experienced staff to assist you with help and advice.

## **TERMS & CONDITIONS OF SALE:**

1. Work for special build machines will not commence unless a 30% deposit has been made and/or official purchase order has been received.
2. The final configuration and optional extras are to be agreed to before manufacturing commences. An extra cost for changing a model will apply after manufacturing has started (if this change leads to extra manufacturing cost or more expensive/extra components) and be charged as a variation cost.
3. Ownership/title of all equipment remains the property of ThoroughClean until paid for in full. Warranty will only be available after this time.
4. Warranty is not service. Any calls placed to service equipment will be chargeable to the client. Earlier replacement of consumable parts than what is required by the maintenance schedule will be at the cost of the client (excluding of course any repairs/replacement of parts required under warranty). Please see the LIMITED WARRANTY information elsewhere in this document.
5. All Rental Spec and Mine Spec model frames will have a hot dip galvanized finish unless elsewhere agreed to in a proposal offered to the client. Industrial Spec frames will have a painted finish or galvanized finish – the latter usually at extra cost.
6. Any additional spares, service kits, nozzle kits, etc are excluded, unless otherwise mentioned in the proposal to the client.
7. Any extra installation and fitting expenses and all electrical or plumbing work required during installation will be at the cost of the client. It is the responsibility of the client to provide adequate pressured water supply of potable quality 15% more than the required flow of the pressure pump specification, and suitable power supply outlet for electrical units where applicable.
8. No responsibility will be taken for late delivery day due to unforeseen circumstances. Please regard building times for special builds and machines out of stock as estimates only.
9. Sale of this unit/s is on an FOB Bundamba, QLD basis unless otherwise agreed to in writing in this proposal and it is the responsibility of the client to insure goods in transit.
10. Our price quoted is valid for 30 days only unless stated otherwise elsewhere in the quote.
11. Where deposits have been paid on special builds, such deposits will in part or in full become non-refundable once building has started. Should a customer decide to cancel an order - all labour and a re-stocking and administration fee for components will be charged to the customer and the balance (if any) repaid to the customer. Any special non-restockable components will be invoiced to the customer.
12. All prices quoted are excluding GST and freight unless otherwise stated.
13. All prices quoted does not include installation (where applicable) or training unless otherwise stated.
14. Installation and training service of \$90/h available in Brisbane Metro only. Other sites subject to additional travel cost.
15. IN NO EVENT SHALL THOROUGHCLEAN BE LIABLE FOR ANY INJURY, EXPENSES, PROFITS, LOSS OR DAMAGE, DIRECT, INCIDENTAL, OR CONSEQUENTIAL, OR ANY OTHER PECUNIARY LOSS ARISING OUT OF THE USE OR INABILITY TO USE ANY PRODUCT DESCRIBED IN THIS DOCUMENT.

DISCLAIMER: Although care has been taken to ensure the accuracy, completeness and reliability of the information provided, technical features may vary due to ongoing improvements and development. The user of the information agrees that the information is subject to change without notice.

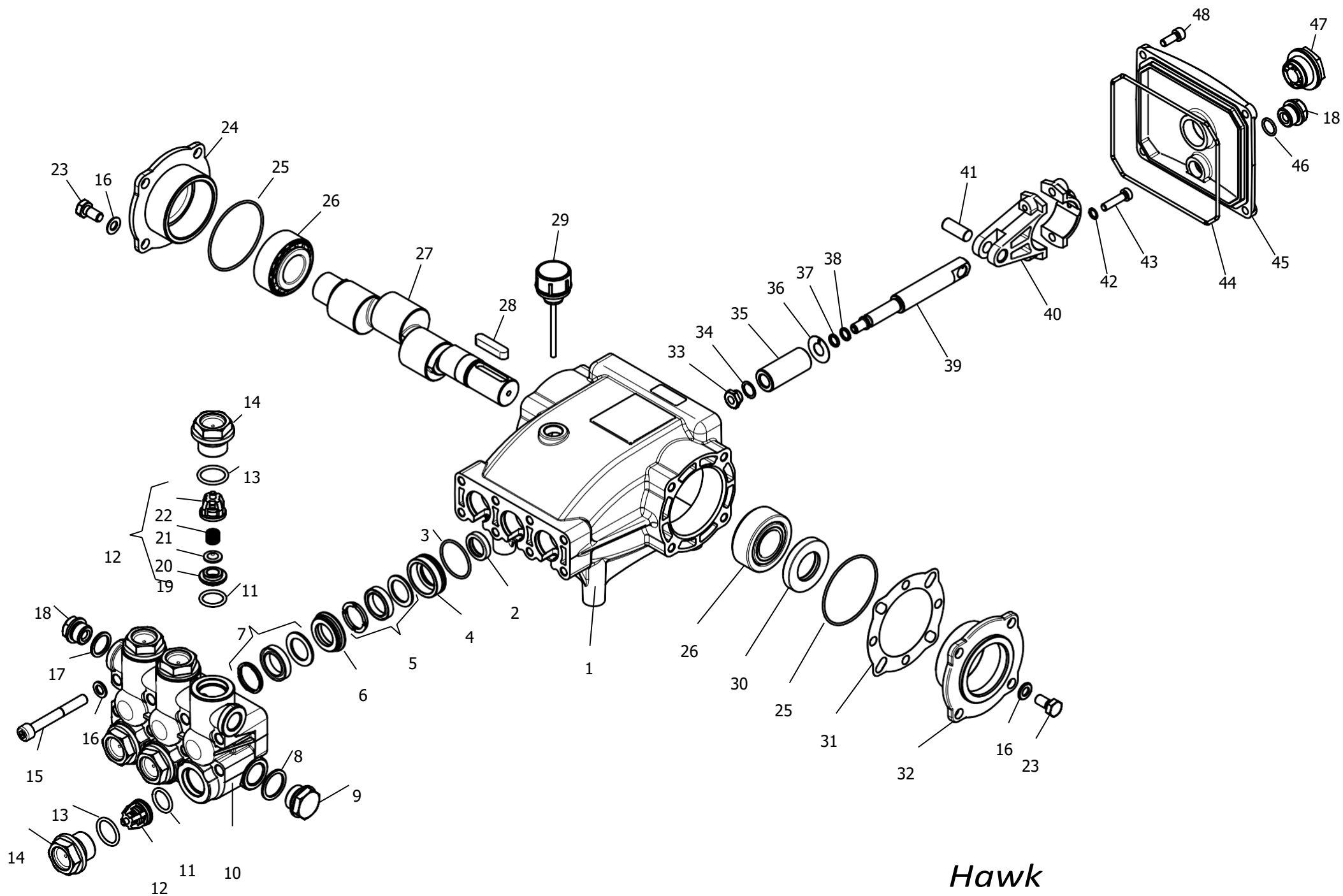

*Hawk*  
*NPM1525 serie 2011*



*NPM1525 pump*  
*2011 series*

Pump Pompe Pumpen Pompa	Pressure Pression Druck Pressione		Volume Debit Leistung Portata		RPM tours/min u.p.m. giri/min	Required HP Puissance HP Leistung HP Potenza HP	Inlet port Entree Eingang Aspirazione	Outlet Sortie Ausgang Mandato	Weight Kg Poids Kg Gewicht Kg Peso Kg
	bar	PSI	l/ min	GPM					
<b>NPM1525</b>	250	3625	15		1450	9.6	G 1/ 2	G 3/8	9.5
				4.7	1740	11.5			

Dimensioni d' ingombro

Overall dimensions

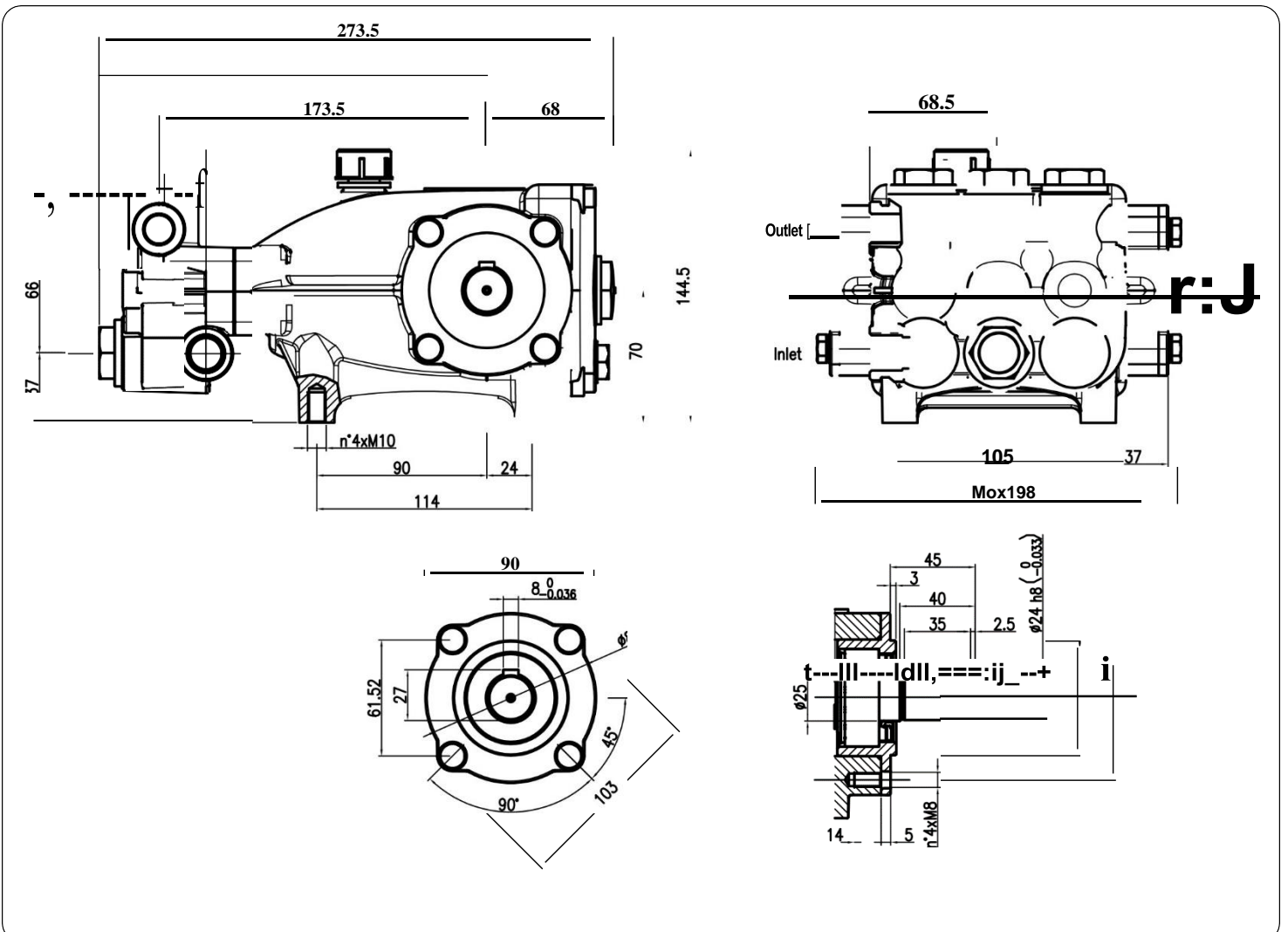

Lubrificazione : Olio SAE 20/ 40W  
 Capacita 0.7 litri

Lubrication: SAE 20/40W Oil  
 Capacity 0.7 liters

Pos.	Codice	Descrizione	Q.tà per Pompa	NPM1525R/L
1	0202.95	Carter	1	
*2	0001.03	Anello radiale	3	
*3	0601.07	"O" Ring Ø1.78x31.47	3	
*4	1201.38	Pressore "U" Ø18	3	
*5	0002.51	Anello tenuta "U" Ø18	3	
*6	0300.16	Diffusore Interm. Ø18	3	
*7	0002.64	Anello tenuta "U" Ø18	3	
*8	0603.07	Guarnizione rame	1	
*9	1601.20	Tappo G1/2	1	
*10	1602.34	Testata	1	
*11	0601.19	"O" Ring Ø2.62x17.13	6	
*12	3604.70	Valvola premontata	6	
*13	0601.65	"O" Ring Ø2.62x20.29	6	
*14	1601.30	Tappo valvola	6	
15	1801.03	Vite M8x65 Dacromet	8	
16	1400.01	Rosetta Ø8.5	16	
*17	0603.06	Guarnizione rame	1	
*18	1601.17	Tappo G3/8	2	
19	1503.18	Sede valvola	6	
20	1202.00	Piattello valvola	6	
21	0900.30	Molla valvola	6	
22	0604.05	Gabbia valvola	6	
23	1802.03	Vite M8x18	8	
24	0500.61	Flangia chiusa	1	
25	0601.63	"O" Ring Ø1.78x60.05	2	◆
26	0200.06	Cuscinetto a rulli 33205	2	
27	0006.15	Albero semplice P.d.F.	1	
28	0206.04	Chiavetta	1	
29	1600.02	Tappo livello olio	1	
30	0001.02	Anello radiale	1	
31	0301.16	Distanziale	1	
32	0500.60	Flangia	1	
*33	0302.19	Dado pistone	3	
*34	1400.12	Rosetta rame Ø 11.2/15x0.5	3	
*35	1200.09	Pistone Ø18	3	
*36	1400.15	Rosetta rame Ø 11.3/24x0.5	3	
*37	0601.03	"O" Ring Ø1.78x7.66	3	
*38	0009.04	Anello antiestrusione	3	
*39	0003.28	Asta pistone	3	
*40	0100.01	Biella	3	
*41	1502.06	Spinotto	3	
*42	1401.02	Rosetta elastica Ø6	6	
*43	1801.05	Vite M6x25	6	
44	0601.88	"O" Ring Ø 2.62x126.67	1	
45	0203.59	Coperchio posteriore	1	
46	0601.14	"O" Ring Ø1.78x14	1	
47	0700.05	Spia livello olio G3/4	1	
48	1801.12	Vite M6x16	4	

		Particolare disponibile solo in kit
--	--	-------------------------------------

*		Particolare disponibile anche in kit
---	--	--------------------------------------

**KIT RICAMBI**

Posizioni incluse	Codice e descrizione		Q.tà per pompa	NPM1525R/L ◆
3- 5- 7	2600.38	Guarnizioni pistone Ø18	1	
3- 4- 5- 6- 7	2600.37	Pacco completo Guarnizioni pistone Ø18	3	
33- 34- 35- 36- 37 38	2612.42	Pistone Ø18	3	
11- 12- 13	2600.08	Valvola completa	6	
2	2608.03	Anelli tenuta olio Asta	1	
3- 4- 5- 6- 7- 8- 9 10- 11- 12- 13- 14 17- 18	2600.75	Testata Completa	1	
39- 40- 41- 42- 43	3100.13	Premontato Biella-Asta pistone	3	

## PARTS LIST

## NPM1525 pump 2011 series

Item	Part Number	Description	Q.ty by Pump	NPM1525R/L
1	0202.95	Crankcase	1	
*2	0001.03	Plunger oil seal	3	
*3	0601.07	"O" Ring Ø1.78x31.47	3	
*4	1201.38	Pressure ring 18mm	3	
*5	0002.51	Low pressure "U" seal, dia.18mm	3	
*6	0300.16	Intermed. ring 18mm	3	
*7	0002.64	High pressure "U" seal, dia.18mm	3	
*8	0603.07	Copper washer G1/2	1	
*9	1601.20	Brass plug G1/2	1	
*10	1602.34	Manifold housing	1	
*11	0601.19	"O" Ring Ø2.62x17.13	6	
*12	3604.70	Valve assembly	6	
*13	0601.65	"O" Ring Ø2.62x20.29	6	
*14	1601.30	Valve plug	6	
15	1801.03	Manifold stud bolt M8x65 Dacromet	8	
16	1400.01	Washer Ø8,5	16	
*17	0603.06	Copper washer G3/8	1	
*18	1601.17	Brass plug G3/8	2	
19	1503.18	Valve seat	6	
20	1202.00	Valve plate	6	
21	0900.30	Valve spring	6	
22	0604.05	Valve cage	6	
23	1802.03	Hexagonal screw M8x18	8	
24	0500.61	Closed bearing housing	1	
25	0601.63	"O" Ring Ø1.78x60.05	2	♦
26	0200.06	Roller bearing 33205	2	
27	0006.15	Single - ended shaft	1	
28	0206.04	Crankshaft key	1	
29	1600.02	Oil dip stick	1	
30	0001.02	Crankshaft seal	1	
31	0301.16	Shim	1	
32	0500.60	Bearing housing	1	
*33	0302.19	Plunger nut	3	
*34	1400.12	Copper spacer Ø 11.2/15x0.5	3	
*35	1200.09	Plunger 18mm	3	
*36	1400.15	Copper spacer Ø 11.3/24x0.5	3	
*37	0601.03	"O" Ring Ø1.78x7.66	3	
*38	0009.04	Teflon ring	3	
*39	0003.28	Plunger rod	3	
*40	0100.01	Connecting rod	3	
*41	1502.06	Connecting rod pin	3	
*42	1401.02	Spring washer Ø6	6	
*43	1801.05	Connecting rod screw M6x25	6	
44	0601.88	"O" Ring Ø 2.62x126.67	1	
45	0203.59	Crankcase cover	1	
46	0601.14	"O" Ring Ø1.78x14	1	
47	0700.05	Sight glass, G3/4	1	
48	1801.12	Screw M6x16	4	

		Part available in kit only
*		Part available in kit also

**SPARE PARTS KIT**

Included Position	Part Number and Description	Q.ty by pump	NPM1525R/L
3- 5- 7	2600.38 Plunger Seals 18 mm	1	♦
3- 4- 5- 6- 7	2600.37 Complete Seals Packing 18 mm	3	
33- 34- 35- 36- 37 38	2612.42 Plunger 18 mm	3	
11- 12- 13	2600.08 Complete Valve	6	
2	2608.03 Plunger oil Seals	1	
3- 4- 5- 6- 7- 8- 9 10- 11- 12- 13- 14 17- 18	2600.75 Complete Manifold	1	
39- 40- 41- 42- 43	3100.13 Connecting Rod-Plunger Rod Assy	3	

## K7 UNLOADER VALVE

<b>K7.0</b>	<b>2.1 - 2.9 GPM @ 0 - 3000 PSI</b>
<b>K7.1</b>	<b>2.9 - 4.2 GPM @ 0 - 3000 PSI</b>
<b>K7.2</b>	<b>4.2 - 6.6 GPM @ 0 - 3000 PSI</b>
<b>K7.3</b>	<b>6.6 - 10.8 GPM @ 0 - 3000 PSI</b>

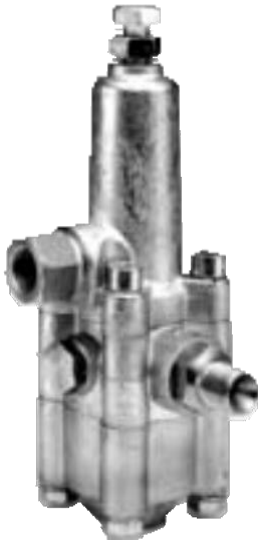

Features all stainless and brass internal parts.  
 New design reduces sensitivity to entrapped air.  
 No external moving parts or springs.  
 Unique barb and flow balance design provides gradual pressure build-up when system is closed.  
 Eliminates high pressure in all lines while unit is in bypass mode.  
 Bypass restrictor eliminates pressure peaks during bypass.  
 Unique balanced piston design permits precise pressure adjustments.  
 Minimum 5% bypass required for operation.  
 Simple design for easy maintenance and service.  
 Adjusting knob is optional.

*General Pump recommends using a safety relief device in conjunction with this unloader valve when installed on a positive displacement pump. General Pump is not liable and assumes no responsibility for this valve when used in a customer's high pressure system.*

### SPECIFICATIONS

Part Number	ZK7.0	ZK7.1	ZK7.2	ZK7.3
Maximum Volume	2.1-2.9 GPM	2.9-4.2 GPM	4.2-6.6 GPM	6.6-10.8 GPM
Maximum Discharge Pressure	0-3000 PSI	0-3000 PSI	0-3000 PSI	0-3000 PSI
Max. Temperature	165°F	165°F	165°F	165°F
Port Sizes: Inlet	3/8-19 BSPP - F	3/8-19 BSPP - F	3/8-19 BSPP - F	3/8-19 BSPP - F
Bypass	3/8-19 BSPP - F	3/8-19 BSPP - F	3/8-19 BSPP - F	3/8-19 BSPP - F
Outlet	3/8-19 BSPP - M	3/8-19 BSPP - M	3/8-19 BSPP - M	3/8-19 BSPP - M
Dimensions	7.50 x 3.75 x 3.50 in.	7.50 x 3.75 x 3.50 in.	7.50 x 3.75 x 3.50 in.	7.50 x 3.75 x 3.50 in.
Weight	4.5 lb.	4.5 lb.	4.5 lb.	4.5 lb.

### PARTS LIST

K7 Unloader Valve				
NO.	PART NO.	DESCRIPTION	KIT NO.	QTY.
1.	92.2368.00	Nut		1
2.	99.3084.00	Screw		4
3.	96.7014.00	Washer		8
4.	90.3849.00	O-Ring	70	1
5.	36.3095.70	Spring Plate		1
6.	94.7466.00	Spring		1
7.	36.3094.66	Seat Valve	70	1
8.	90.5052.00	Anti-Extrusion Ring	70	1
9.	90.3820.00	O-Ring	70	1
10.	90.3582.00	O-Ring	70	1
11.	36.3097.02	Piston Assembly	70	1
12.	94.7464.00	Spring	70	1
13.	90.2766.00	Packing	70	1
14.	96.7215.00	Washer		1
15.	90.2565.00	Packing	70	1
16.	90.5063.00	Anti-Extrusion Ring	70	1
17.	99.3127.00	Screw		4
18.	99.3663.00	Screw		1
19.	36.3098.02	Optional Adjust. Knob		1
20.	36.3090.41	Upper Body		1
21.		Nipple		1
	10.0078.70	<b>K7.0</b> , 3/8 BSPP, Ø3.0 mm		
	10.0078.70	<b>K7.1</b> , 3/8 BSPP, Ø3.0 mm		
	10.0160.70	<b>K7.2</b> , 3/8 BSPP, Ø3.25 mm		
	10.0161.70	<b>K7.3</b> , 3/8 BSPP, Ø3.5 mm		
22.	90.3833.00	O-Ring	70	1
23.		Nozzle		1
	10.0076.66	<b>K7.0</b> , Ø2.2 mm		
	10.0077.66	<b>K7.1</b> , Ø2.5 mm		
	10.0162.66	<b>K7.2</b> , Ø2.75 mm		
	10.0163.66	<b>K7.3</b> , Ø3.0 mm		
24.	90.3823.00	O-Ring	70	1
25.	90.3863.00	O-Ring	70	1
26.	36.3091.41	Central Body		1
27.	98.2041.00	Cap Screw		2
28.	90.3585.00	O-Ring	70	2
29.	90.3871.00	O-Ring	70	1
30.	36.3092.41	Lower Body		1
31.	96.7380.00	Washer		1
32.		Nipple		1
	36.3117.70	<b>K7.0</b> , 3/8 BSPP		
	36.3116.70	<b>K7.1</b> , 3/8 BSPP		
	36.3118.70	<b>K7.2</b> , 3/8 BSPP		
	36.3119.70	<b>K7.3</b> , 3/8 BSPP		
Repair Kit 70				
Includes No.'s: 4, 7, 8, 9, 10, 11, 12, 13, 15, 16, 22, 24, 25, 28, 29				

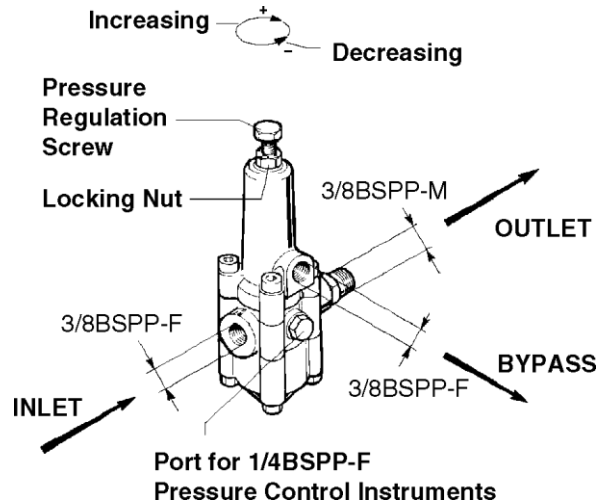
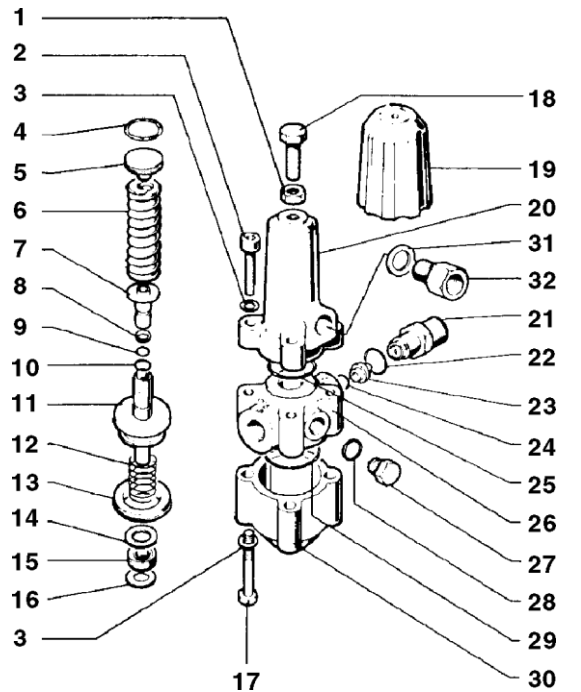

### INSTALLATION

Select an unloader appropriate for the pressure and flow of your system (see specification chart). This unloading valve is a flow-through design and should be mounted on the discharge line of the pump in any position (horizontal or vertical) which allows easy access to the adjusting bolt. A pressure gauge should be installed on either side of the port of the unloader to accurately read pressure during adjustment. **Minimum 5% bypass is required for proper operation.**

### WARRANTY

General Pump accessories are warranted by the manufacturer to be free from defects in material and workmanship. Period of warranty shall be 90 days from date product is received by original buyer. Liability of manufacturer under the foregoing warranty is limited to **repair or replacement** at the option of manufacturer of that product which according to the manufacturer's investigation was deemed defective at time of shipment. Damage resulting from neglect, abuse, tampering or misapplication voids this warranty. This warranty is in lieu of all other warranties, expressed or implied, including any warranty of merchantability and/or any and all other obligations or liabilities on the part of the manufacturer.



[www.generalpump.com](http://www.generalpump.com)

300110 Rev. B  
2-95







**Wiring Colour Code:**

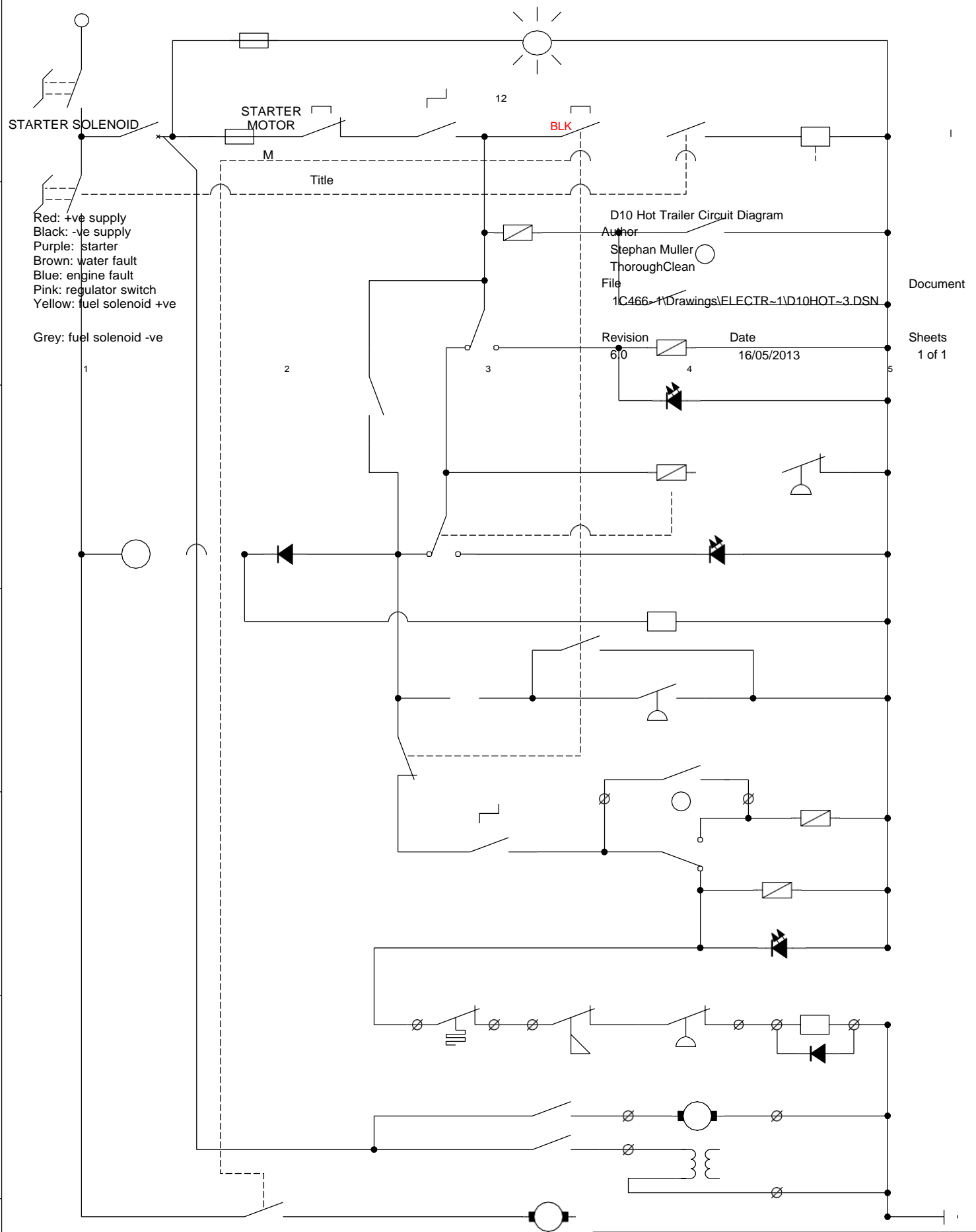

Document  
 Sheets  
 1 of 1
