



## LPS 55 SCABBLER / TAMPER



## OPERATION & MAINTENANCE



**TRELAWNY**<sup>TM</sup>

SURFACE PREPARATION TECHNOLOGY

[www.trelawnyspt.com](http://www.trelawnyspt.com)

# OPERATION

## Foreword

Thank you for purchasing the LPS 55. This manual contains the necessary maintenance information for you to ensure proper operation and care for your machine.

**It is essential for you to read through these manuals thoroughly.**

In the unlikely event that you experience problems with your LPS 55, please do not hesitate to contact your local dealer or agent. We always welcome feedback and comments from our valued customers.

## General Information

Before operating the LPS 55 Scabbler/Tamper, this manual must be read and understood by the operator, if in any doubt ask your supervisor before using this equipment. Failure to follow these instructions could result in damage to the LPS 55 Scabbler / Tamper and/or personal injury.

Trelawny SPT Ltd disclaims all responsibility for damage to persons or objects arising as a consequence of incorrect handling of the tool, failure to inspect the tool prior to starting work for damage, or other faults that may influence the operation or safe working of the tool, or failure to follow the safety regulations listed or applicable to the job site.

The tool is primarily designed for concrete reduction and for the removal of laitance from concrete.

The LPS 55 is also available as a Tamper and can subsequently be fitted with a Tamper head for the compaction of soil, tarmac or aggregate.

This tool must not be used in a fixture.

A VL LPS 55 is also available in a vibration reduced Compactor or Scabbler version. All versions can be used both indoors and out.

## Safety

Always, read through these instructions first before use.

### IMPORTANT

Before operating this equipment, the operator should read this manual. Whenever possible, he/she should be trained how to operate the machine by an experienced person. Trial and error is not the safe way to become familiar with this piece of equipment.

**Do** wear Personal Protective Equipment including safety goggles, footwear, ear defenders and gloves.

In some environments it will be necessary to wear facemasks or breathing apparatus.

**Do** be aware that this tool is not electrically insulated.

**Do** ensure that this tool is lubricated **daily**.

**Do** be aware that this tool can create dust and flying debris.

**Do** be aware of others working around you.

**Do** keep hands and clothing away from moving parts.

**Do** store this tool in a secure and dry environment.

**Always observe safe working practices and local safety regulations at all times.**

**Do not** allow the tool to run unattended.

**Do not** allow the tool to run continuously whilst not in contact with the surface being prepared.

**Do not** modify this tool in any way, as this will invalidate the warranty and could lead to serious injury.

**Do not** use this tool in potentially explosive environments.

**Do not** drag this tool by the air hose.

**Do not** use petrol (gasoline), thinners or any other high flash point solvent to clean the tool.

## Air Supply

The compressed air supply must be free from water and dirt. The installation of a filter/regulator/lubricator air preparation set (with moisture trap) adjacent to the tool is **strongly recommended**.

Always clear the air hose before connection to the tool. Ensure that no moisture (condensation) is present in the air hose.

Ensure that a minimum 19mm (3/4") bore air hose is used and that all couplings are secure; leak free and in good condition.

Limit the length of air hose to 15M (50ft). Where extra length is necessary, for each additional 15M (50ft) of air hose used, the pressure drop is approximately 0.16bar (3psi).

**Correct operating pressure is 6.2bar (90 psi).**

Do not let the operating pressure fall below 5.5bar (80p.s.i.) or rise above 6.9bar (100 psi) absolute maximum.

Preferably, the compressor should be able to supply a minimum of 18.9 L/s (40cfm) free air.

In particularly cold weather it is recommended that a proprietary anti-freeze lubricating oil be used.

### Recommended Lubricants

Oil the tool daily before use. Put a liberal quantity of one of the following zinc free air tool lubricants through the air inlet. It is recommended that an inline lubricator be installed in the air hose adjacent to the tool.

SHELL	Naturelle HF
CASTROL	Carelube HTG 22

### Cleaning

At intervals of no more than 100 hours use, or if operation becomes unproductive, or if the piston shows signs of sticking, dismantle and clean with highly refined paraffin. Replace any worn components as necessary.

Immediately after cleaning, thoroughly oil the tool with one of the recommended lubricants.

## Risk of Hand-Arm Vibration Injury

These tools may cause Hand-arm Vibration Syndrome injury if their use is not managed.

We advise you to carry out a risk assessment and to implement measures such as; limiting exposure time [i.e. actual trigger time, not total time at work], job rotation, ensuring the tools are used correctly, ensuring the tools are maintained according to our recommendations, and ensuring that the operators wear personal protective equipment [PPE] **particularly gloves and clothing** to keep them warm and dry. Employers should consider setting up a programme of health surveillance to establish a benchmark for each operator and to detect any early symptoms of vibration injury.

We are not aware of any PPE that provides protection against vibration injury by attenuating vibration emissions.

See '**Specifications**' section for vibration emission data.

Further advice is available from our Technical Department.

## Starting Work

Prior to operating the tool check: -

That all fittings are secure, free from air leaks and that air hoses are in good condition.

That all parts of the tool are fully screwed together and secure, if you are in any doubt ask your supervisor before using this equipment.

That the air pressure is correct for this tool **6.2 bar (90 psi).**

That a liberal amount of lubricant has been put into the air inlet of the tool. (See recommended lubricants)

Before operating the tool ensure that the tool is not near your chin or face.

Safe use of this tool requires a solid stance and secure foothold; the operator must adopt a firm and stable position at all times.

On start up, the tool will rise two to three inches (75mm).

To operate the tool pull the lever towards the handle grip.

Let the tool do the work; allow a period of time to become accustomed to the tool. The tool does not require any down force to operate; excessive pressure will prevent the tool from working effectively. Maintain contact with the work surface with sufficient pressure only to keep the tool under control.

Bush Hammer style headed pistons are best suited to concrete reduction and for laitance removal; these may reduce the likelihood of damage to the aggregate, ensuring that a stronger bond is created with the next layer.

Cruciform headed pistons are suited to the reduction of concrete or where a smoother finish is required; these will reduce the aggregate as well as the concrete surface.

**To switch off, simply release the throttle lever.**

Do not press down on the tool, excessive pressure will prevent the tool from working to its full capacity and will increase the vibration emissions.

# OPERATION / MAINTENANCE

Handled correctly the LPS 55 Scabblor/Tamper will work quickly and efficiently. Gloves and personal protective equipment **must** be worn when using this tool.

Care must be taken to avoid damaging or tripping over the air hose.

## Maintenance

Only a competent person, in a suitably equipped workshop, must carry out maintenance. **Disconnect the tool from the air supply before carrying out any of the following operations.**

## Dismantling

Clean all debris from the exterior of the tool.

### Handle/Valve Body servicing

Hold main shaft in a vice, about three inches (75mm) away from the cylinder assembly, slacken off the locknut (10) using a 38mm (1½) wrench on the spanner flats. Retain the sealing washer (10a). Then unscrew the valve body assembly from the main shaft.

Secure the valve body assembly (14) in a vice, holding on the main body casing. Using a suitable spanner unscrew the adaptor (19) from the valve body, remove the spring (21) and spring seat (20), retrieve the valve stem (24) with its O'Rings. Using a 6mm punch, drive out the throttle lever pivot pin (25) and withdraw the throttle lever (12).

### Piston and Cylinder removal (Threaded Piston)

Hold the Scabblor head (7) or Tamper foot securely in a vice, then using a 1¼" (32mm) spanner on the piston flats, unscrew the Scabblor head or Tamper foot. Using a suitable wrench on the spanner flats on the cylinder remove the cylinder and then the piston (6) from the cylinder (2). Remove the piston O' Ring (not shown in the exploded diagram) and remove cylinder wiper seal (5) and O' Rings (3) and (4).

### (Pin fit Piston)

Hold the Scabblor head (7) or Tamper foot securely in a vice, then using a 12mm punch drive out the retaining spiral pin (8) and remove the Scabblor head or Tamper foot. Using a suitable wrench on the spanner flats on the cylinder remove the cylinder and then the piston (6) from the cylinder (2). Remove cylinder wiper seal (5) and O' Rings (3) and (4).

## Assembly

Before any assembly takes place, ensure all parts are clean and have a film of air tool oil lubrication unless otherwise stated. Avoid lubricating oil contaminating the threads of the cylinder (2), the main shaft (9) and the valve body (14). These will require securing with a thread-locking adhesive. It is good practice to renew all the O'Rings. Replace any parts showing signs of wear; paying particular attention to the small bore of the cylinder.

### Handle/Valve Body Assembly

Apply general-purpose bearing grease to the valve stem, insert valve stem (24) with its O'Rings (22) and (23) into valve guide followed by the spring (21). Screw in adaptor (19) by hand and using a 32mm (1¼) spanner fully tighten. Using a 6mm punch align the hole in the throttle lever (12) with the holes in the valve body (14). Using a small hammer fit the throttle lever pin (25).

### Piston and Cylinder Assembly (Threaded Piston)

Fit a new wiper seal (5) and O' rings (3) and (4) to the appropriate small and large grooves on the cylinder (2). Fit a new O' ring on to the piston (6) and insert into the cylinder. Screw on the Scabblor head (7) or Tamper foot until it butts up against shoulder of piston. Hold in a vice, gripping on the Scabblor head or Tamper foot using the spanner flats. Fully secure using a suitable wrench on the piston's spanner flats to a torque of 500lbs/ft (678Nm). Ensure that the threads of the cylinder and casing assembly are clean and free of oil; apply a bead of Loctite 243 or similar to the first few threads of the cylinder. Hold the casing assembly in a vice using the flats provided and screw in the cylinder assembly by hand, using a suitable wrench on the spanner flats on the cylinder tighten to a recommended torque of 135Nm (100 lbs/ft).

### Piston and Cylinder Assembly (Pin fit Piston)

Fit a new wiper seal (5) and both O' rings (3) and (4) to the appropriate small and large grooves on the cylinder (2). Insert the piston (6) into the cylinder. Fit the Scabblor head (7) or Tamper foot until it butts up against the front face of the piston (6). Align the holes in the piston and Scabblor head or Tamper foot. A 7/16" Allen Key is a good fit for this purpose or use a suitable piece of wooden dowelling. Hold the spiral pin (8) with a pair of pliers to avoid hitting the fingers, and then using a hammer, drive in the spiral pin centrally to secure the Scabblor head or Tamper foot.

Ensure that the threads of the cylinder and casing are clean and free of oil; apply a bead of Loctite 243 or similar to the first few threads of the cylinder. Hold the casing assembly in a vice on the flats provided and screw in the cylinder assembly by hand. Using a suitable wrench on the spanner flats on the cylinder tighten to a recommended torque of 135Nm (100 lbs/ft).

### Body Assembly

Hold main shaft in a vice, about three inches (75mm) away from the valve assembly. Ensure sealing washer (10a) is in place and that the threads of the valve body (14) and main shaft (9) are clean and free of oil; apply a bead of Loctite 243 or a similar product to the first few threads of the Handle and screw on the valve body until hand tight. Tighten the locknut (10) using a 38mm (1 1/2") wrench on the spanner flats.

## Machine Storage

### Storage: over 3 months.

Clean the outside of the machine and inspect the piston and cutterhead for wear, replace any worn parts as required. Put a liberal amount of lubricant into the air inlet of the tool and run the tool for a few seconds to disperse the oil around the tools internal components. Lubricate the exposed part of the piston and cylinder. (See recommended lubricants)

Cover the machine to protect it: Store the machine in a dry place.

When next used, continue as per "Starting work section".

## Disposal

When the tool and its accessories are taken out of service for disposal, it is recommended that: - It is dismantled into component form, segregated according to material composition and disposed of using waste recycling processes specified by local regulations.

## Machinery Directive Information

This tool has been designed and produced in accordance with the following directives:

2006/42/EC Machinery Directive and applicable harmonised standard: EN ISO 1 1148-4:2010

If your company has any problem with our products or would like to discuss the possibility of an improvement being made to them, then please do not hesitate to contact us. Your comments are both important and appreciated.

	SCABBLER/TAMPER	
Length	1300mm (51")	H1* Indicates test taken from the primary handgrip location at the trigger. H2* Indicates test taken from the secondary handgrip location.
Weight	13.45kg (29.6lbs)	(K)** Equals the factor of uncertainty, which allows for variations in measurement and production. Vibration data figures are <b>tri-axial</b> , which gives total vibration emission.
Blows per minute	1300	
Air Pressure	6.2 bar (90psi) - (1/2" BSP Air inlet)	<b>Risk of Hand Arm Injury</b> Because of various factors, the range of vibration emission during intended use of this tool is expected to be between 38.6m/s <sup>2</sup> – 54.0m/s <sup>2</sup> for the Scabblor. The vibration is dependent on the task, the operators grip, and feed force employed etc.
Air Consumption	11.61 lps (25cfm)	Noise level measured in accordance with: EN ISO 15744: 1999
Sound pressure level	98.0db(A)	Vibration measured in accordance with: EN ISO 28927 and EN ISO 20643
Vibration Level (H1)*	38.6m/s <sup>2</sup> (k)**	
Vibration Level (H2)*	37.5m/s <sup>2</sup> (k)**	

# EXPLODED VIEW

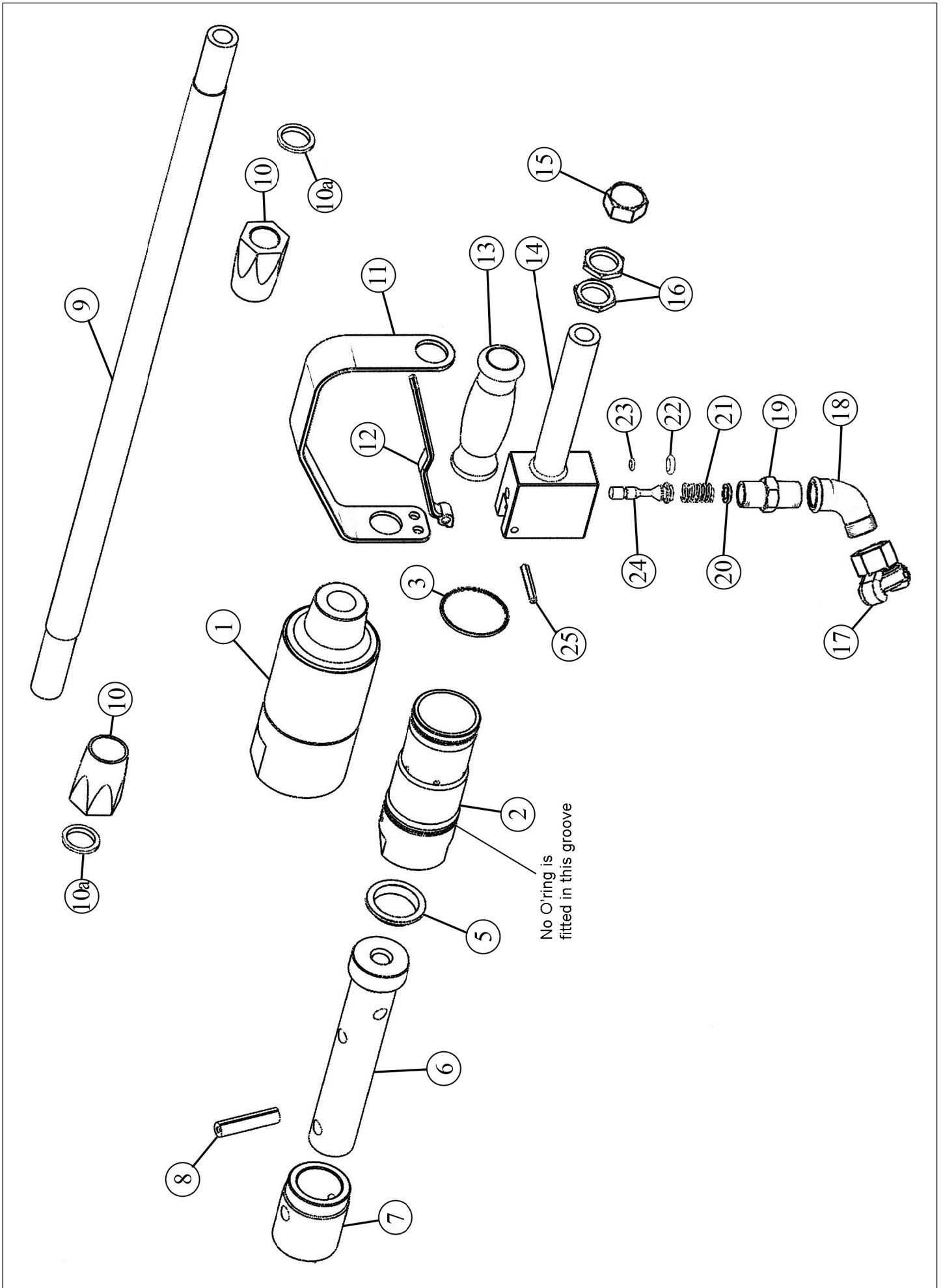

# PART NUMBERS

Item No	Part No	Description	Item No	Part No	Description
1	411.5011	Body	17	843.0765	3/4" Claw coupling
2	613.5001	Cylinder	18	819.5020	90° Adapter
3	809.6599	Cylinder O'Ring (Small)	19	627.5011	Adaptor (Spring seat)
5	829.5001	Wiper Seal	20	627.5012	Spring Seat
6	612.5005	Piston (Pin Fit)	21	712.5001	Valve Spring
	612.5001	Piston (Screw Fit)	22	809.5599	Valve Stem Seat O'Ring
7	426.5359	TCT tipped 5 point Scabbler Head (Pin fit)	23	809.0069	Valve Stem Seal O'Ring
	N/A	TCT tipped Cruciform Scabbler Head (Pin fit)	24	618.5025	Valve Stem
	426.5051	TCT tipped 5 point Scabbler Head (Screw fit)		448.5025	Valve Stem - including O'Rings
	426.5052	TCT tipped Cruciform Scabbler Head (Screw fit)	25	813.0636	Roll Pin
8	813.1050	Spirol Pin (Pin fit heads)			
9	624.5011	Main Shaft			<b>Not shown in exploded view</b>
10	625.5012	Locknut (Main shaft)		809.6499	Piston O'Ring (Screw fit)
10a	810.9003	Sealing Washer		450.5001	100 x 100 Compactor Foot (Screw fit)
11	665.5011	Trigger Guard		450.5011	100 x 100 Compactor Foot (Pin fit)
12	649.5011	Throttle Lever		450.5003	127 x 152mm Compactor Foot (Screw fit)
13	822.2000	Rubber Grip		450.5013	127 x 152mm Compactor Foot (Pin fit)
14	422.5005	Valve Body		450.5006	100 x 200mm Compactor Foot (Screw foot)
15	634.5015	Blanking Cap		450.5016	100 x 200mm Compactor Foot (Pin foot)
16	625.5011	Locknut (Valve body handle)		450.5007	127 Diameter Compactor Foot (Screw fit)
				450.5017	127 Diameter Compactor Foot (Pin fit)
				852.0812	Trigger Guard Screw

TROUBLE SHOOTING		
Poor performance or lack of power	Low air pressure.	Ensure that the air pressure is correct at 90psi, max 100psi.
	If tool has been left for some time without use, the oil may dry out slightly causing a sticky residue.	Strip tool down and re-oil.
	Tool worn out, can you feel excessive side ways movement between the piston and cylinder bore.	Replace the piston and cylinder, along with a new scraper seal.
	Cutterhead worn out.	Replace cutterhead
	Applying too much down force.	Only apply sufficient down force to stop the tool from bouncing.
Tool continues to run with trigger released	Valve seal may have become dislodged through the tool being disconnected with the trigger in the open position.	Ensure that the trigger has not been taped or wired in the open position. Do not use quick release couplings to switch tool off.
Cutterhead seized on piston	If the tool has been laid up or used with water present, rust may have built up between the piston and cutter.	In extreme cases it may be necessary to apply heat to release the cutter head, otherwise a releasing agent may be sufficient.

All rights reserved. Any unauthorised use or copying of the contents or part thereof is prohibited.  
This applies to trademarks, model denominations, part numbers and drawings.

Use only genuine Trelawny spares.  
**The use of non-Trelawny spare parts invalidates the warranty.**



# TRELAWNY

**SURFACE PREPARATION TECHNOLOGY**



Trelawny SPT Ltd  
Trelawny House, 13 Highdown Road, Sydenham Industrial Estate, Leamington Spa, Warwickshire,  
CV31 1XT, United Kingdom  
Telephone: +44 (0)1926 883781  
Fax: +44 (0)1926 450352  
Email: sales@trelawny.co.uk  
Website: www.trelawnyspt.com